

FOLDING LEVEL BANDER

Model Nos. 3628 - 3632 - 3664 - 3684

Table of Contents

Click the Level Bander model number below for a
Parts Manual for each model.

3628 & 3632 - 8 & 12 Row Folding Level Bander

- Pages 3 - 9

3631 - 12 Row 30" Folding Level Bander

- Pages 10 - 20

3664 - 12 Row 30" Folding Buster Level Bander

- Pages 21 - 31

3684 - 12 Row 30" Folding Buster/Crumbler Level Bander

- Pages 32 - 41



8 & 12 ROW FOLDING LEVEL BANDER

Model No. 3628 & 3632

3628 - 3632 - Folding Level Bander

MAIN FRAME

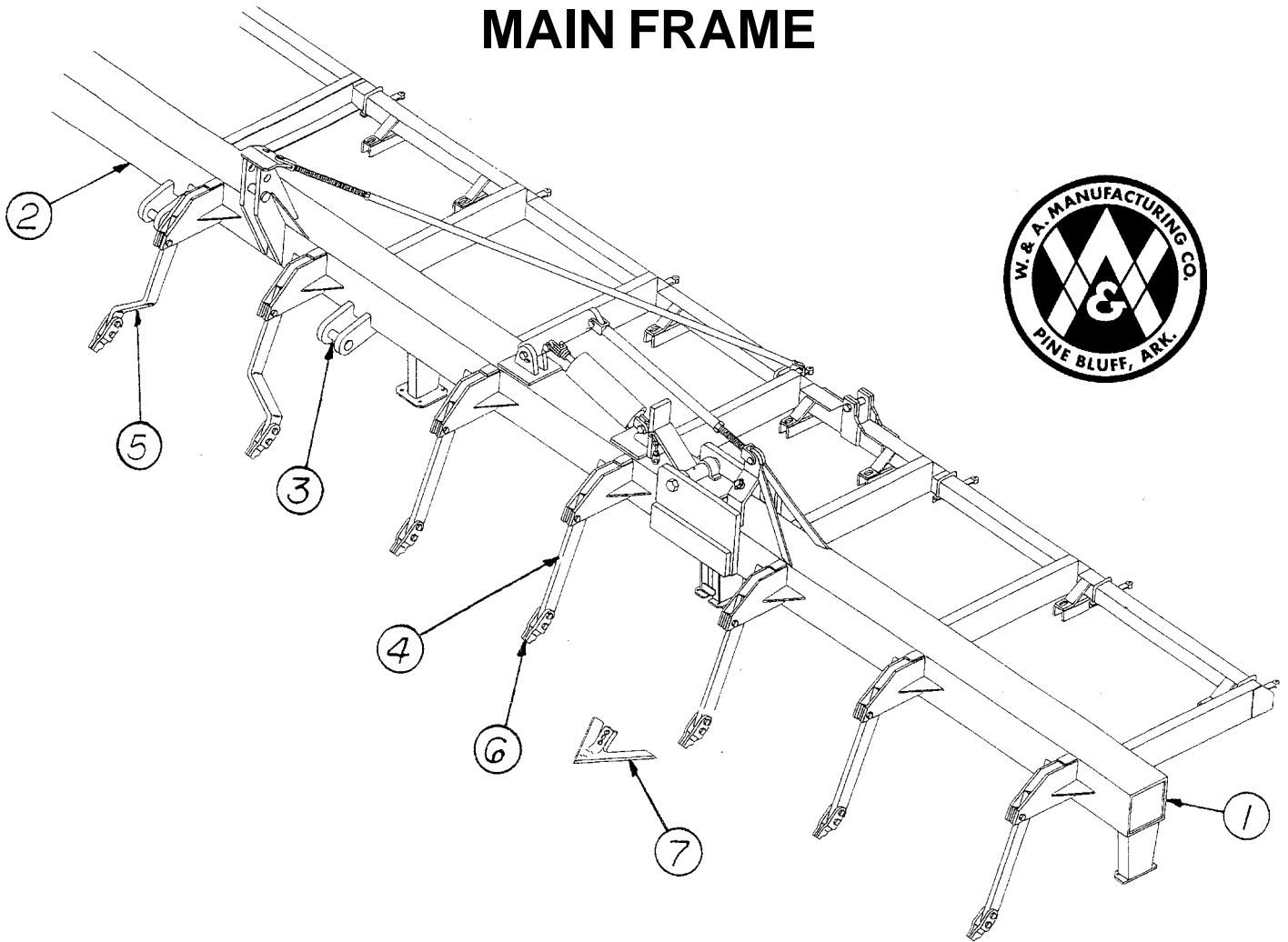

<u>ITEM NO.</u>	<u>PART NO.</u>	<u>WT. LBS.</u>	<u>DESCRIPTION</u>	<u>QTY. REQ.</u>
1	301594	532	Wing Eight Row - LH*	
-	301593	532	Wing Eight Row - RH*	
-	301596	664	Wing Twelve Row - LH*	
-	301595	664	Wing Twelve Row - RH*	
2	301584	935	Center Section Eight Row*	
-	301585	1,267	Center Section Twelve Row*	
3	300841	4¼	Hitch Pin -- 1-7/16" x 9"	
-	301600	3	Pull Pin -- 1-7/16" x 6-1/2"	
4	201489	23¼	Slanted Root Rooter Shank - 28"	
5	201490	24½	Slanted Offset RH Root Rooter Shank - 28"	
-	201491	24½	Slanted Offset LH Root Rooter Shank - 28"	
6	300244	3½	Friction Trip Foot -- Root Rooter	
7	474016	4½	16" Mixed Land Sweep	
-	411834		Plow Bolt -- 7/16" x 2" NC - Gr 5 - #3 - Zinc	
-	411836		Plow Bolt -- 7/16" x 3" NC - Gr 5 - #3 - Zinc	
-	412007		Hex Nut -- 7/16" - 14 - Gr 2 - Zinc	
-	413507		Lock Washer -- 7/16" - Zinc	

3628 - 3632 - Folding Level Bander

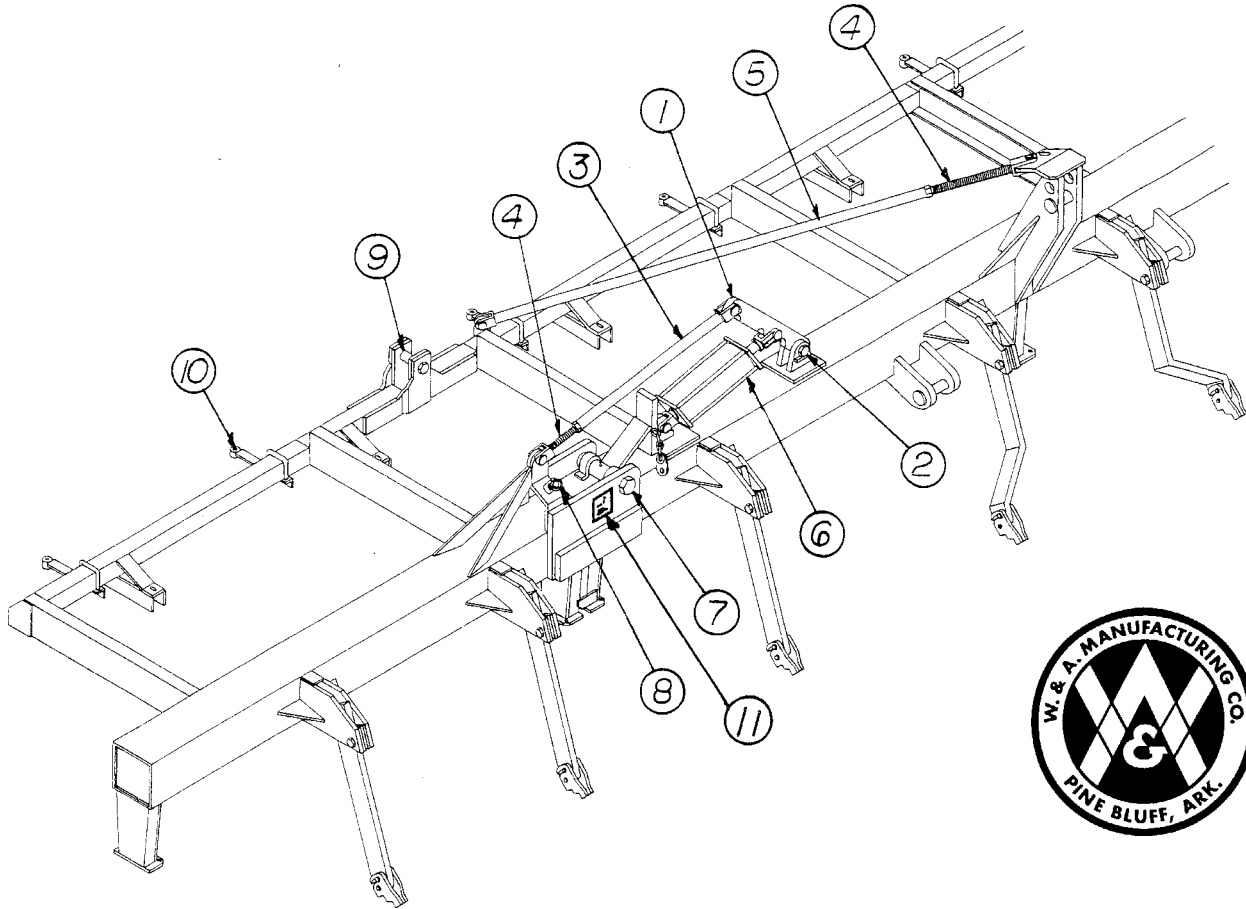

<u>ITEM NO.</u>	<u>PART NO.</u>	<u>WT. LBS.</u>	<u>DESCRIPTION</u>	<u>QTY. REQ.</u>
1	202917	18½	Cylinder Attaching Bracket - 12NF 12LBF	
2	203417	1¼	Cylinder Bracket Bolt - Level Bander	
3	301597	6¾	Turnbuckle Body - 22-1/2" (Level Bander)	
4	300381	5¼	Turnbuckle Bottom (Rod) Pulv.	
5	301598	15¾	Truss Rod Body 58" -- 6LB 8LBF	
-	301599	21¾	Truss Rod Body -- 8LB 12LBF - 91"	
6	476007	34	Hydraulic Cylinder -- 3-1/2" x 8" (8 Row)	
-	476011	71	Hydraulic Cylinder -- 5" x 8" (12 Row)	
-	203385	1¼	Cylinder Pin for 5" x 8" Cylinder	
-	446184	¼	½" x ¼" Swivel Orifice Elbow*	
-	477050	-	Seal Kit -- 3-1/2" x 8" & 16" Lion Cyl. (1-1/4" Rod)	
-	477053	-	Seal Kit -- 5" x 8" Lion Cyl. (1-1/2" Rod)	
7	411677	4¼	Hex Bolt -- 1-1/4" x 11" NC - Gr 5 - Zinc - Full Body	
-	412420	¼	Jam Nut -- 1-1/4" - 7 - Gr 2 - Zinc	
8	416204	-	1/4" Klik Pin - Zinc	
9	411316	1½	Hex Bolt -- 1" x 6-1/2" NC - Gr 2 - Zinc	
-	412416	¼	Jam Nut -- 1" - 8 - Gr 2 - Zinc	
10	301601	1½	Spray Nozzle Bracket -- Level Bander	
-	415108	½	1/2" U Bolt x 2-1/2" x 4" Leg - Grade 5	
11	461135	-	Safety Decal -- "Overhead Wing Hazard"	

3628 - 3632 - Folding Level Bander

REEL

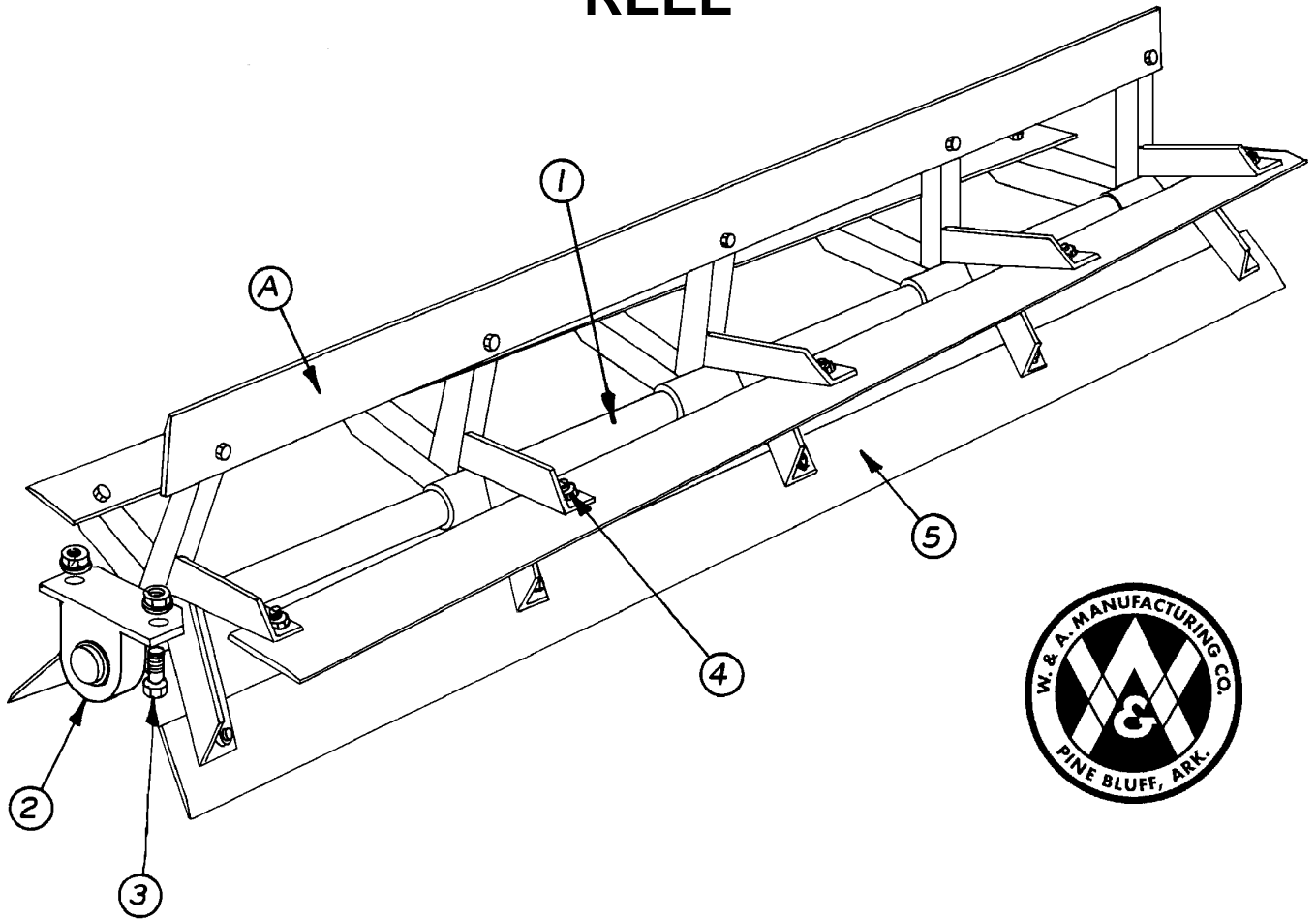

ITEM NO.	PART NO.	WT. LBS.	DESCRIPTION	QTY. REQ'D FOR 1 MACHINE	
				8 ROW	12 ROW
A	770020	235	Spiral 6 ft Reel Complete w/Bearings	4	3
-	770021	340	Spiral 106" Reel Complete w/Bearings...(Wings)	-	2
1	300451	116	77" Reel Shaft w/5 Support Brackets*	4	3
-	301067	187	114" Reel Shaft w/7 Support Brackets*	-	2
2	482101	4	1-15/16" Pillow Block & Bearing - Pulv.	8	10
-	481215	1	1-15/16" Bearing w/Lock Collar Peer - #G1115-KRRB-S1115K	-	-
-	480006	3	Pillow Block for 1-15/16" Bearing	-	-
3	411562	-	Hex Bolt -- 5/8" x 2-1/2" NC - Gr 5 - Zinc	16	20
-	410009	-	Lock Nut -- 5/8" NC - Zinc	16	20
-	413010	-	Flat Washer -- 5/8" - Zinc	16	20
4	411211	-	Hex Bolt -- 5/8" x 1-1/4" NC - Gr 2 - Zinc	100	145
-	410009	-	Lock Nut -- 5/8" NC - Zinc	100	145
5	200539	20	Spiral Pulvamer Blade x 72"	20	15
-	202168	31	Spiral Pulvamer Blade x 106"	-	10

3628 - 3632 - Folding Level Bander

ROLLING BASKETS

1" Shaft and Bearings

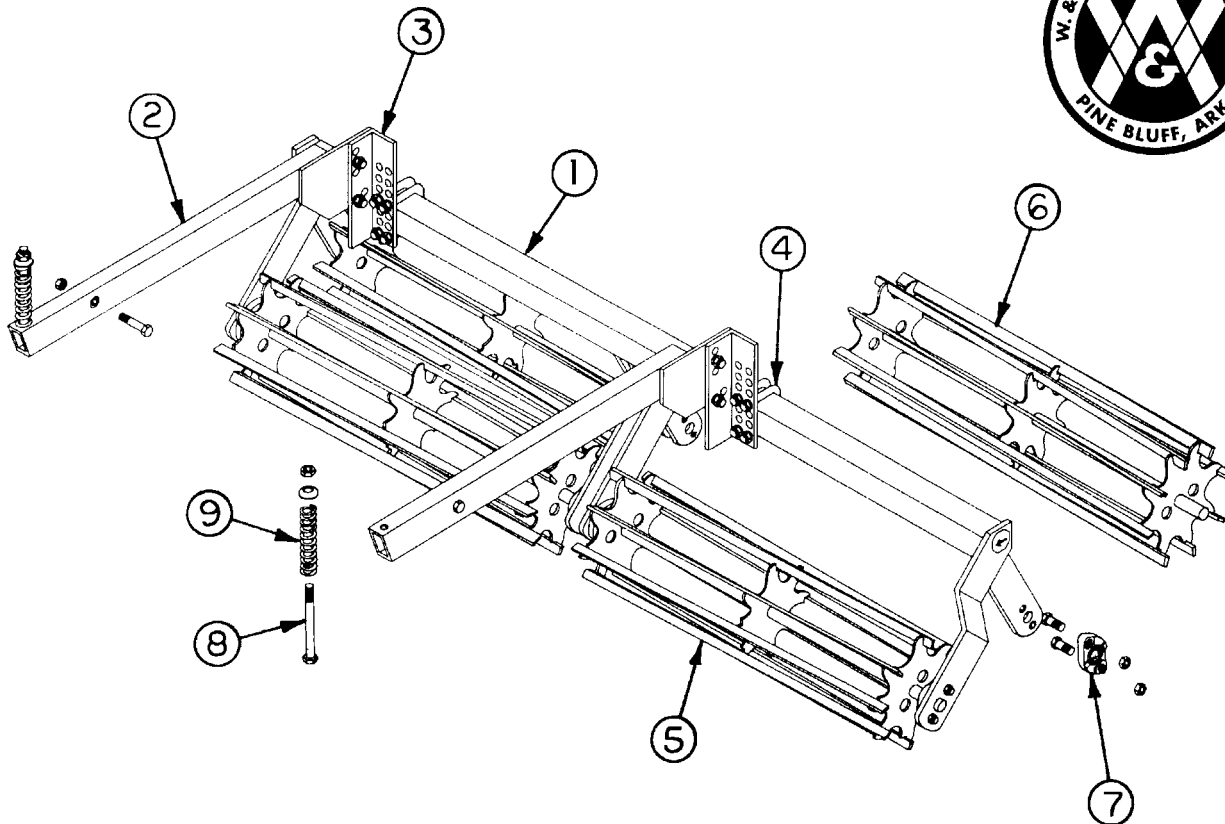

<u>ITEM NO.</u>	<u>PART NO.</u>	<u>WT. LBS.</u>	<u>DESCRIPTION</u>	<u>QTY. REQ.</u>
1	301287	100	Two Row Frame -- 1" Rolling Baskets	
-	301288	150	Three Row Frame -- 1" Rolling Baskets	
-	301289	200	Four Row Frame -- 1" Rolling Baskets	
2	301290	20½	Arm -- Rolling Baskets	
3	202745	5½	Connecting Angle – AS SHOWN* (Four Row)	
-	202729	5½	Connecting Angle - Rolling Baskets (Opposite Hand)	
-	411545	-	Hex Bolt -- 1/2" x 1-1/2" NC - Gr 5 - Zinc	
4	415108	½	1/2" U-Bolt x 2-1/2" x 4" Leg - Grade 5	
5	301294	36¼	Rolling Basket Only -- Front (1" Shaft)	
-	202749	2.7	Front Blade Only For Rolling Basket	
6	301295	36¼	Rolling Basket Only -- Rear (1" Shaft)	
-	202750	2.7	Rear Blade Only For Rolling Basket	
7	482010	1	Bearing Assem -- 1" Rolling Basket	
-	481221	-	1" Bearing & Collar - Roll Baskets Peer	
-	411508	-	Hex Bolt, 3/8" x 1½" Gr. 5*	
8	411237	1	Hex Bolt -- 5/8" x 8" NC - Gr 2 - Zinc	
-	200412	-	Formed Head Holder	
-	410009	-	Lock Nut -- 5/8" NC - Zinc	
-	202350	-	Cup Washer For Pulv Dragboard Brkt Spg	
9	471006	1½	Compression Spring Dragboard Leg	

3628 - 3632 - Folding Level Bander

ROLLING BASKETS

1¼" Shaft and Bearings

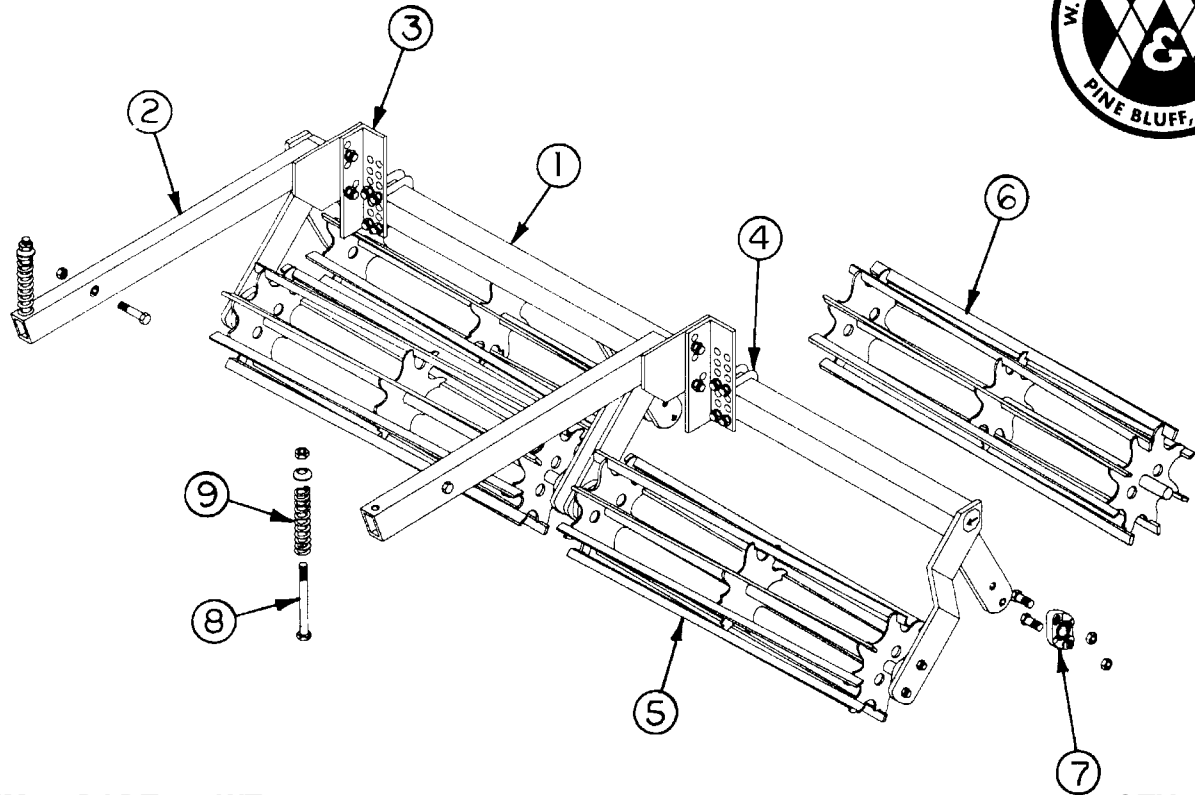

<u>ITEM NO.</u>	<u>PART NO.</u>	<u>WT. LBS.</u>	<u>DESCRIPTION</u>	<u>QTY. REQ.</u>
1	301954	100	Two Row Frame*	
-	301955	150	Three Row Frame*	
-	301956	200	Four Row Frame*	
2	301290	20½	Arm -- Rolling Baskets	
3	202745	5½	Connecting Angle – AS SHOWN* (Four Row)	
-	202729	5½	Connecting Angle - Rolling Baskets (Opposite Hand)	
-	411545	-	Hex Bolt -- 1/2" x 1-1/2" NC - Gr 5 - Zinc	
4	415108	½	1/2" U-Bolt x 2-1/2" x 4" Leg - Grade 5	
5	301948	41¼	Front Rolling Basket Only -- 1-1/4" Shaft	
-	202749	2.7	Front Blade Only for Rolling Baskets	
6	301949	41¼	Rear Rolling Basket Only -- 1-1/4" Shaft	
-	202750	2.7	Rear Blade Only for Rolling Baskets	
7	482024	2	1-1/4" Cast Flange Bearing Assm RB	
-	481288	-	1-1/4" Bearing Only w/Lock Collar RB	
-	411534	-	Hex Bolt -- 7/16" x 1-1/2" NC - Gr 5 - Zinc (Outside Bearings)	
-	204145	-	Bearing Spacer* (Inside Bearings)	
-	411539	-	Hex Bolt -- 7/16" x 3-1/2" NC - Gr 5 - Zinc (Inside Bearings)	
-	410007	-	Lock Nut -- 7/16" NC - Zinc	
8	411237	1	Hex Bolt -- 5/8" x 8" NC - Gr 2 - Zinc	
-	200412	-	Formed Head Holder	
-	410009	-	Lock Nut -- 5/8" NC - Zinc	
-	202350	-	Cup Washer for Pulv Dragboard Brkt Spg	
9	471006	1½	Compression Spring Dragboard Leg	

3628 - 3632 - Folding Level Bander

RATCHET ADJ. GAUGE WHEELS

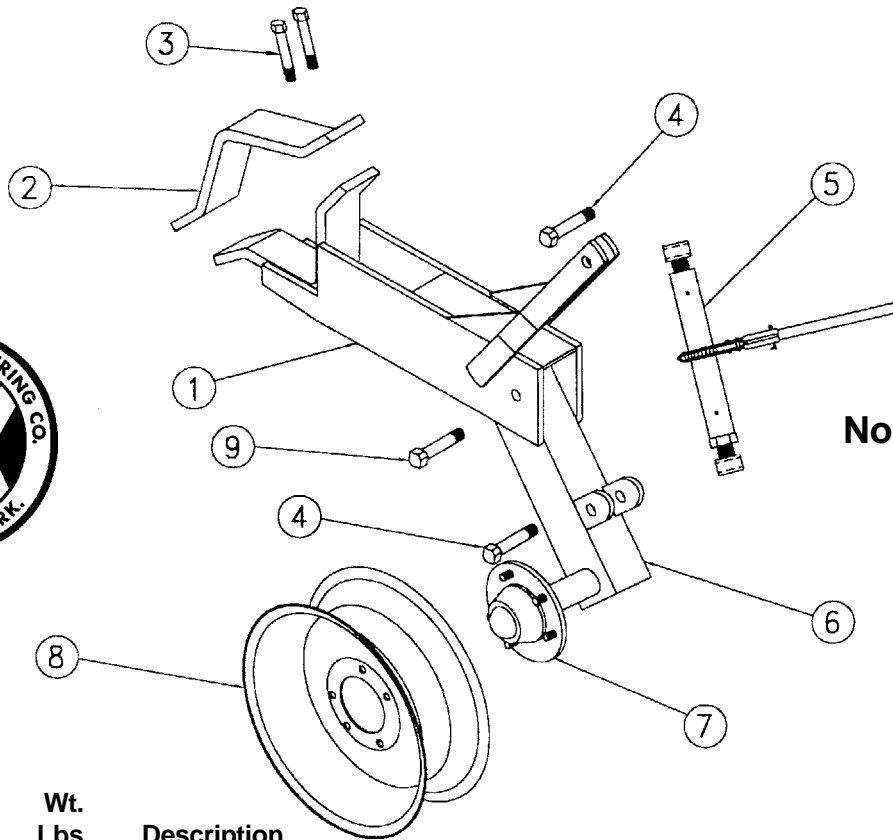

No. 1335

Item No.	Part No.	Wt. Lbs.	Description	Qty. Req'd
1	301611	60	Holder	1
2	202320	10	Backing Clamp for 7" x 7" Bar	1
3	411565	¼	Hex Bolt -- 5/8" x 3-1/2" NC - Gr 5 - Zinc	4
-	412010	-	Hex Nut -- 5/8" - 11 - Gr 2 - Zinc	4
-	413510	-	Lock Washer -- 5/8" - Zinc	4
4	411251	½	Hex Bolt -- 3/4" x 4" NC - Gr 2 - Zinc	2
-	412012	-	Hex Nut -- 3/4" - 10 - Gr 2 - Zinc	2
-	413512	-	Lock Washer -- 3/4" - Zinc	2
5	302025	11½	Ratchet Crank Assembly	1
6	301605	34	RH Leg w/Hub -- #1335 Gauge Wheel	1
-	301606	34	LH Leg w/Hub -- #1335 Gauge Wheel	1
7	491119	11	5 Hole Hub Complete - Q-719	1
-	491007	9¾	Hub w/Cups Only - Q-719	1
-	481205	¼	Cone - Q719 - LM67048	1
-	496010	-	Outer Cup - Q719 - LM67010	1
-	481204	¼	Cone - Q719 - LM48548	1
-	496011	-	Inner Cup - Q719 - LM48510	1
-	497010	-	Grease Seal - Q719 - CR 15190	1
-	490006	¼	Hub Cap - Q719	1
-	490015	-	1/2" NF Lug Nut	5
-	490017	-	Drive-In Hub Bolt - Q719	5
-	412164	-	Slotted Nut -- 7/8" - 14 Spindle	1
-	490034	-	Spindle Washer -- 7/8" - Q719	1
8	493007	17	15" x 5" x 5 Hole Wheel	1
9	411254	¾	Hex Bolt -- 3/4" x 5" NC - Gr 2 - Zinc	1
-	412012	-	Hex Nut -- 3/4" - 10 - Gr 2 - Zinc	1
-	413512	-	Lock Washer -- 3/4" - Zinc	1

**LEVEL BANDER
150° FOLDING BAR**

Model No. 3631 -- 12 @ 30" Row

3631 - 12 Row 30" Folding Level Bander

REEL FRAME

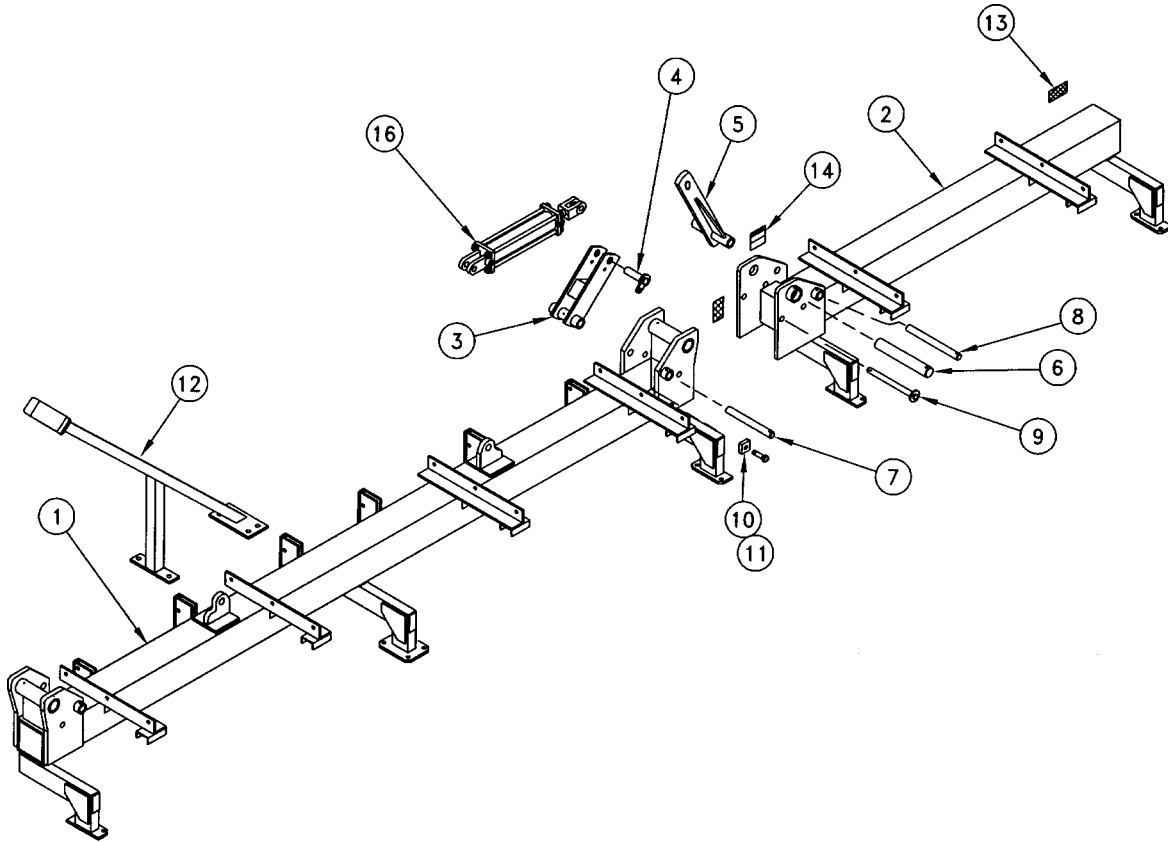

ITEM NO.	PART NO.	WT. LBS.	DESCRIPTION	QTY. REQ.
1	302202	856	Center Reel Frame	1
2	302203	359	Wing Reel Frame - RH - Shown	1
-	302204	359	Wing Reel Frame - LH	1
3	302085	21	Follow Arm - 150° Fold Bar	2
4	302086	2 ³ / ₄	Cylinder Lock Pin - 150° Fold Bar	2
-	411545	-	Hex Bolt -- 1/2" x 1 1/2" NC - Gr. 5 - Zinc.....	2
-	413008	-	Flat Washer -- 1/2" - Zinc	2
-	413508	-	Lock Washer -- 1/2" - Zinc.....	2
5	302084	23 ¹ / ₄	Folding Arm - 150° Fold Bar	2
6	204388	11 ¹ / ₂	Pivot Pin -- 2" x 13-1/8" - 150° Fold Bar	2
-	416133	-	Roll Pin -- 1/2" x 3 1/2" - Zinc	2
7	204389	4	Follow Arm Pin -- 1 1/4" x 11 1/2" - 150° Fold Bar	2
-	416109	-	Roll Pin -- 5/16" x 2 1/2" - Zinc	4
8	204390	4 1/2	Folding Arm Pin -- 1 1/4" x 13-1/8" - 150° Fold Bar	2

REEL FRAME

(Continued)

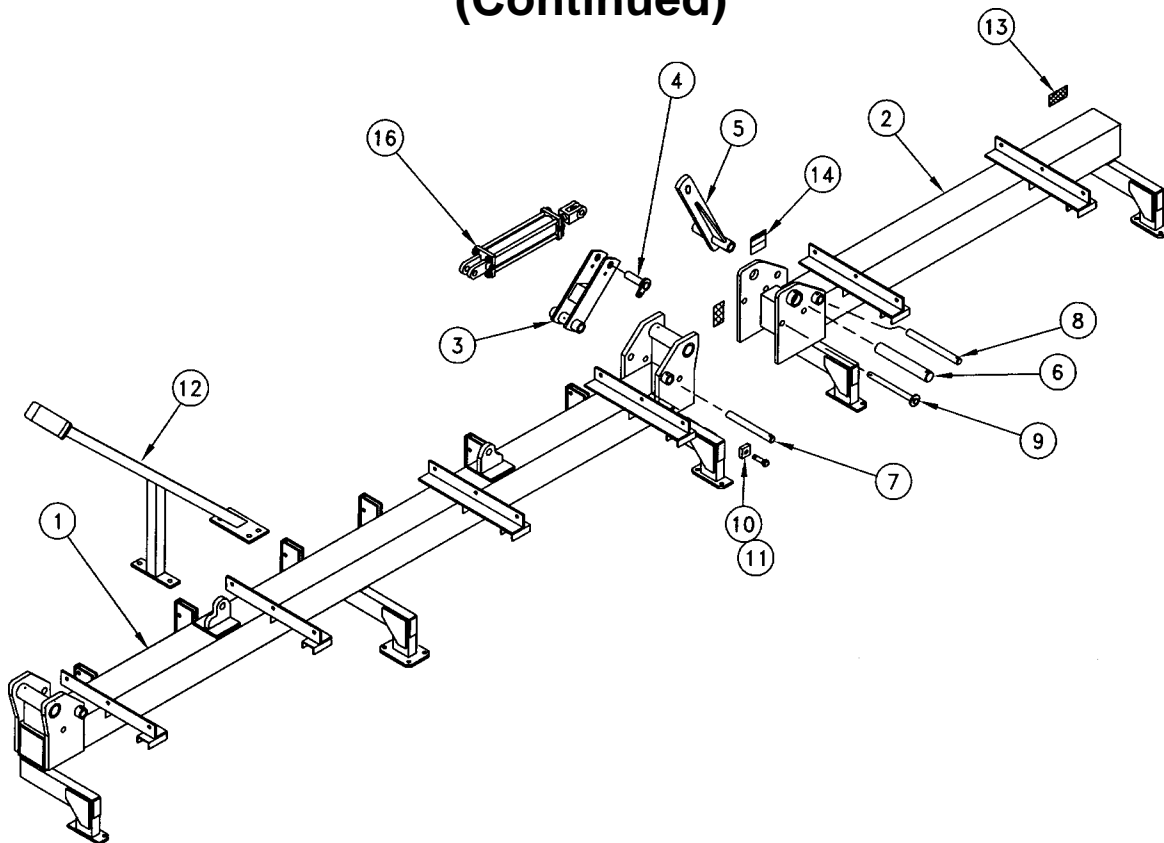

<u>ITEM NO.</u>	<u>PART NO.</u>	<u>WT. LBS.</u>	<u>DESCRIPTION</u>	<u>QTY. REQ.</u>
9	302087	3	Wing Lock Pin - 150° Fold Bar	2
-	416204	-	Klik Pin -- 1/4" - Zinc.....	2
10	204398	3/4	Stop Block - 150° Fold Bar	4
11	411584	1/4	Hex Bolt -- 3/4" x 2" NC - Gr. 5 - Zinc.....	4
-	413512	-	Lock Washer -- 3/4" - Zinc	4
12	302148	29	Wing Support Stand.....(48" Tube)	2
-	415004	2½	3/4" Sq. U-Bolt x 7" x 9" Leg	4
-	412012	-	Hex Nut -- 3/4" - 10 - Gr. 2 - Zinc	8
-	413512	-	Lock Washer -- 3/4" - Zinc	8
13	461200	-	Decal Amber Reflector.....(On Front of Wings)	4
14	461135	-	Warning Decal - Overhead Wing Hazard	2
16	476026	100	Hydraulic Cylinder -- 5" x 16"	2
-	446188	1/4	1/2" x 1/2" Swivel Orifice Elbow	4

3631 - 12 Row 30" Folding Level Bander

REEL

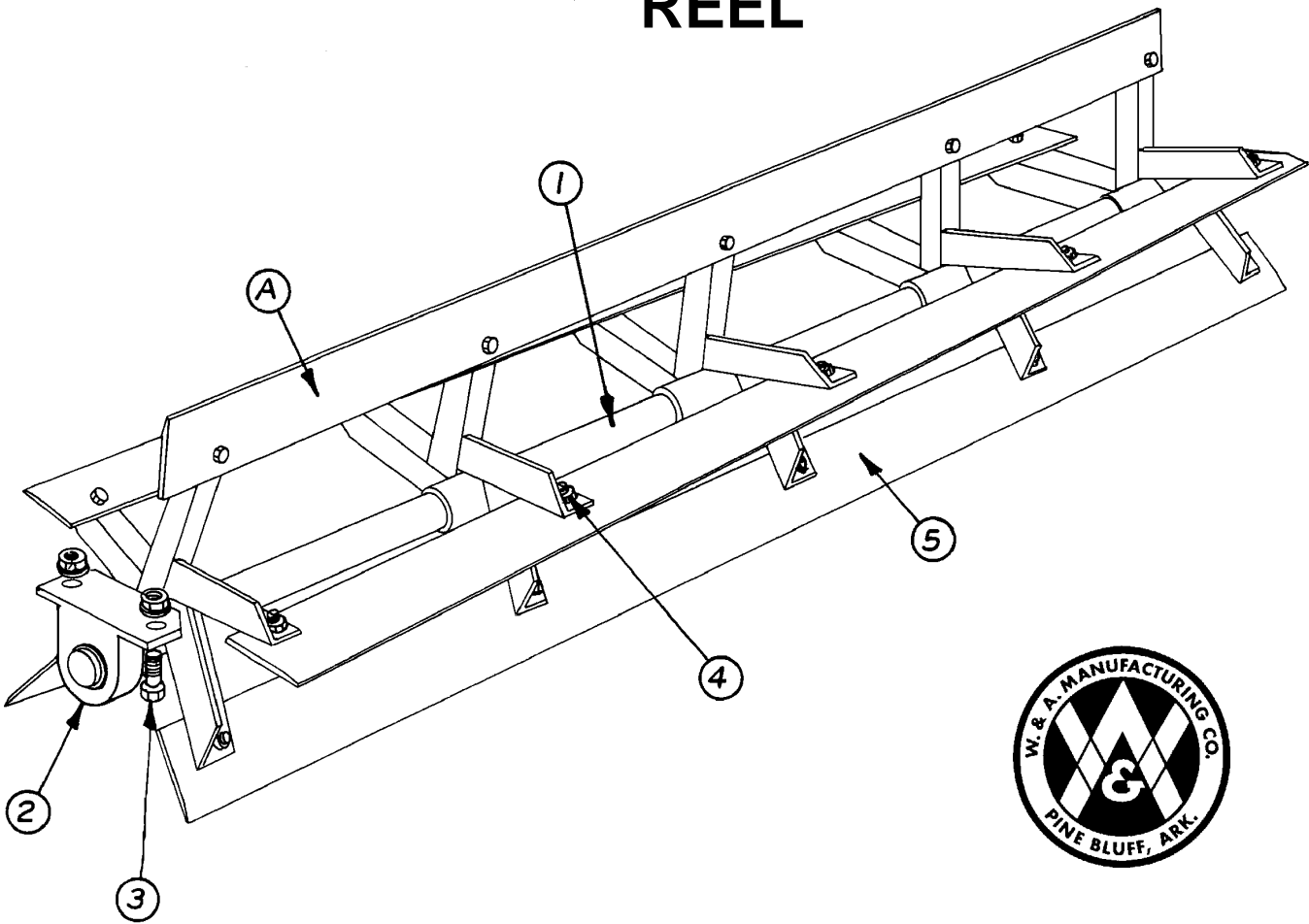

ITEM NO.	PART NO.	WT. LBS.	DESCRIPTION	QTY. REQ. FOR 1 MACHINE
A	770031	288	Spiral 84" Reel Complete w/Bearings	4
1	302149	152	Spiral 89" Reel Shaft w/6 Support Brackets	4
2	482101	4	1-15/16" Pillow Block & Bearing Complete	8
-	481215	1	1-15/16" Bearing w/Lock Collar	-
-	480006	3	Pillow Block for 1-15/16" Bearing	-
3	411562	-	Hex Bolt -- 5/8" x 2 1/2" NC - Gr. 5 - Zinc	16
-	410009	-	Lock Nut -- 5/8" NC - Zinc	16
-	413010	-	Flat Washer -- 5/8" - Zinc	16
4	411211	-	Hex Bolt -- 5/8" x 1 1/4" NC - Gr. 2 - Zinc	120
-	410009	-	Lock Nut -- 5/8" NC - Zinc	120
5	204482	24 3/4	Spiral Pulvamer Blade x 84"	20

ROOT ROOTERS

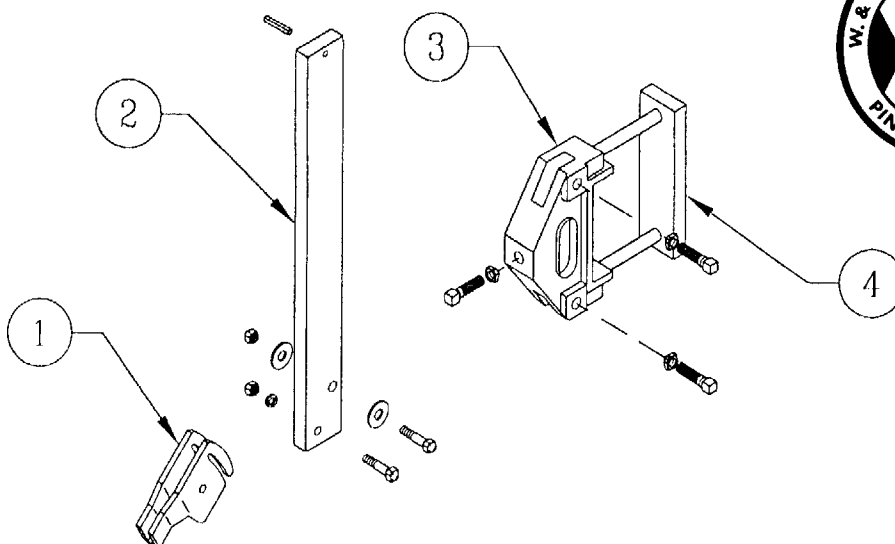

<u>ITEM NO.</u>	<u>PART NO.</u>	<u>WT. LBS.</u>	<u>DESCRIPTION</u>	<u>QTY. REQ. FOR 1 MACHINE</u>
1	300244	3½	Friction Trip Foot -- Root Rooter	12
-	411549	-	Hex Bolt -- 1/2" x 2½" NC - Gr 5 - Zinc	24
-	412008	-	Hex Nut -- 1/2" - 13 - Gr 2 - Zinc	24
-	413508	-	Lock Washer -- 1/2" - Zinc	24
-	413008	-	Flat Washer -- 1/2" - Zinc	24
2	201557	23¼	Vertical Root Roter Shank -- 28"	8
N/I	201561	23½	Vertical Shank 3" Offset - RH	2
N/I	201562	23½	Vertical Shank 3" Offset - LH	2
-	416120	-	Roll Pin -- 3/8" x 2" - Zinc	12
3	479069	13½	Bolt-On Shank Holder - 7" Tool Bar	6
-	414828	-	Square Head Set Screw -- 5/8" x 1¾"	18
-	412310	-	Square Nut -- 5/8" - 11 - Gr 2 - Zinc	18
-	412410	-	Jam Nut -- 5/8" - 11 - Gr 2 - Zinc	18
4	204274	9	Backing Plate For Bolt-on Shank Holder 7"	6
-	411601	1¼	Hex Bolt -- 3/4" x 8½" - Gr 5 - Zinc	12
-	412012	-	Hex Nut -- 3/4" - 10 - Gr 2 - Zinc	12
-	413512	-	Lock Washer -- 3/4" - Zinc	12
N/I	474016	4½	16" Mixed Land Sweep(1/4")	12
-	411834	-	Plow Bolt -- 7/16" x 2" NC - Gr 5 - #3 - Zinc	12
-	411836	-	Plow Bolt -- 7/16" x 3" NC - Gr 5 - #3 - Zinc	12
-	412007	-	Hex Nut -- 7/16" - 14 - Gr 2 - Zinc	24
-	413507	-	Lock Washer -- 7/16" - Zinc	24

363 - 12 Row 30" Folding Level Bander

BASKET FRAME

2013 and Later

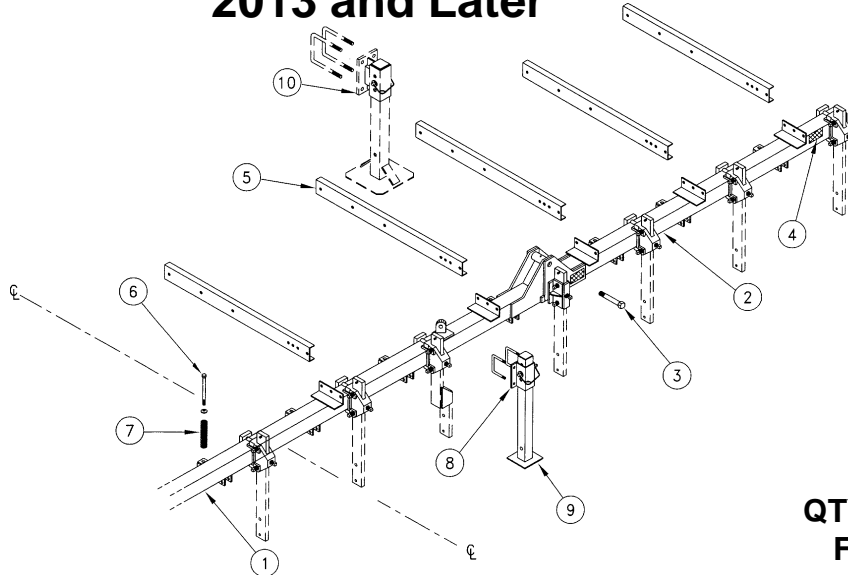

<u>ITEM NO.</u>	<u>PART NO.</u>	<u>WT. LBS.</u>	<u>DESCRIPTION</u>	<u>QTY. REQ. FOR 1 MACHINE</u>
1	302205	285	Rear Center Basket Frame(4" Sq. Tube)	1
2	302206	173	Rear Wing Basket Frame - RH -- Shown(4" Sq.)	1
-	302207	173	Rear Wing Basket Frame - LH(4" Sq.)	1
3	411671	3½	Hex Bolt -- 1¼" x 8" NC - Gr. 5 - Zinc.....	2
-	412420	½	Jam Nut -- 1¼" - 7 - Gr. 2 - Zinc	4
-	413117	-	Machine Washer -- 2¼" OD x 1¼" ID x 14 ga	4
4	461201	-	Decal -- Red Reflector - 4½" x 2".....	4
5	204480	21½	Connecting Channel -- 4" x 48"	10
-	411560	-	Hex Bolt -- 5/8" x 1½" NC - Gr. 5 - Zinc	50
-	410009	-	Lock Nut -- 5/8" NC - Zinc	50
6	411237	1	Hex Bolt -- 5/8" x 8" NC - Gr. 2 - Zinc.....	12
-	202350	-	Cup Washer for Spring.....(5/8")	12
-	410009	-	Lock Nut -- 5/8" NC - Zinc.....	12
7	471006	1½	Compression Spring.....(7" Coil)	12
8	773976	76	Rear Mount Parking Stand Assembly (Pair)	1
-	301860	7½	Parking Stand Bracket for 4" Sq. Tube.....	2
-	415010	1	5/8" Sq. U-Bolt x 4" x 5¼" Leg.....	4
-	412010	-	Hex Nut -- 5/8" - 11 - Gr. 2 - Zinc	8
-	413510	-	Lock Washer -- 5/8" - Zinc	8
-	416230	¾	3/4" Safety Lock Pin x 5-1/2" OAL - Zinc	2
9	301856	22	Parking Stand Leg	2
10	773961	114	Front Mount Parking Stand Assembly (Pair)	1
-	302222	19½	Holder - Front Parking Stand(Used w/Rear Busters)	2
-	302223	30½	Parking Stand Leg (3" Sq. Tube x 36")	2
-	415004	2½	3/4" U-Bolt x 7" x 9" Leg	4
-	412012	-	Hex Nut -- 3/4" - 10 - Gr. 2 - Zinc.....	8
-	413512	-	Lock Washer -- 3/4" - Zinc	8
-	416230	¾	3/4" Safety Lock Pin x 5½" OAL - Zinc.....	2

363 - 12 Row 30" Folding Level Bander
4" BOLT-ON SHANK HOLDER
Optional

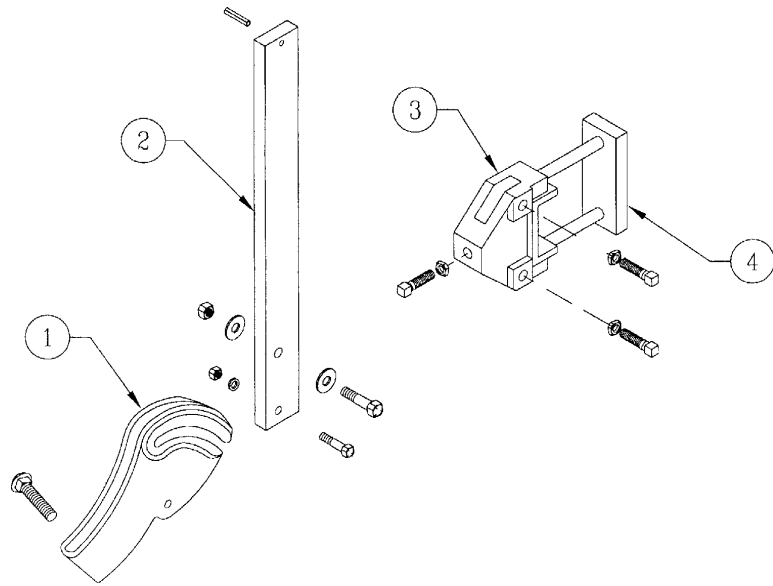

<u>ITEM NO.</u>	<u>PART NO.</u>	<u>WT. LBS.</u>	<u>DESCRIPTION</u>	<u>QTY. REQ'D</u>
1	479075	6½	Friction Trip Foot	13
-	411549	-	Hex Bolt -- 1/2" x 2½" NC - Gr. 5 - Zinc	13
-	411563	½	Hex Bolt -- 5/8" x 3" NC - Gr. 5 - Zinc	13
-	411794	½	Carriage Bolt -- 3/4" x 3½" NC - Gr. 5 - Zinc	13
-	410009	-	Lock Nut -- 5/8" NC - Zinc	13
-	410012	-	Lock Nut -- 3/4" NC - Zinc	13
-	412008	-	Hex Nut -- 1/2" - 13 - Gr. 2 - Zinc	13
-	413056	-	Flat Washer, Heavy -- 5/8" - Zinc	26
-	413058	-	Flat Washer, Heavy -- 3/4" - Zinc	13
-	413508	-	Lock Washer -- 1/2" - Zinc	13
2	204210	25	Vertical Shank C1080	11
-	302002	28	3" Offset Shank -- RH	1
-	302003	28	3" Offset SHank -- LH	1
-	416120	-	Roll Pin -- 3/8" x 2" - Zinc	13
3	479065	10¼	Bolt-On Shank Holder - 4" Tool Bar	11
-	414828	-	Square Head Set Screw -- 5/8" x 1-3/4"	39
-	412010	-	Hex Nut -- 5/8" - 11 - Gr. 2 - Zinc	39
-	412410	-	Jam Nut -- 5/8" - 11 - Gr. 2 - Zinc	39
4	204275	6	Backing Plate for Bolt-on Shank Holder 4"	11
-	411595	7¾	Hex Bolt -- 3/4" x 5½" - Gr. 5 - Zinc	22
-	412012	-	Hex Nut -- 3/4" - 10 - Gr. 2 - Zinc	22
-	413512	-	Lock Washer -- 3/4" - Zinc	22
N/I	474031	7¼	#11N Furrower	13

BASKET FRAME

2012 and Prior

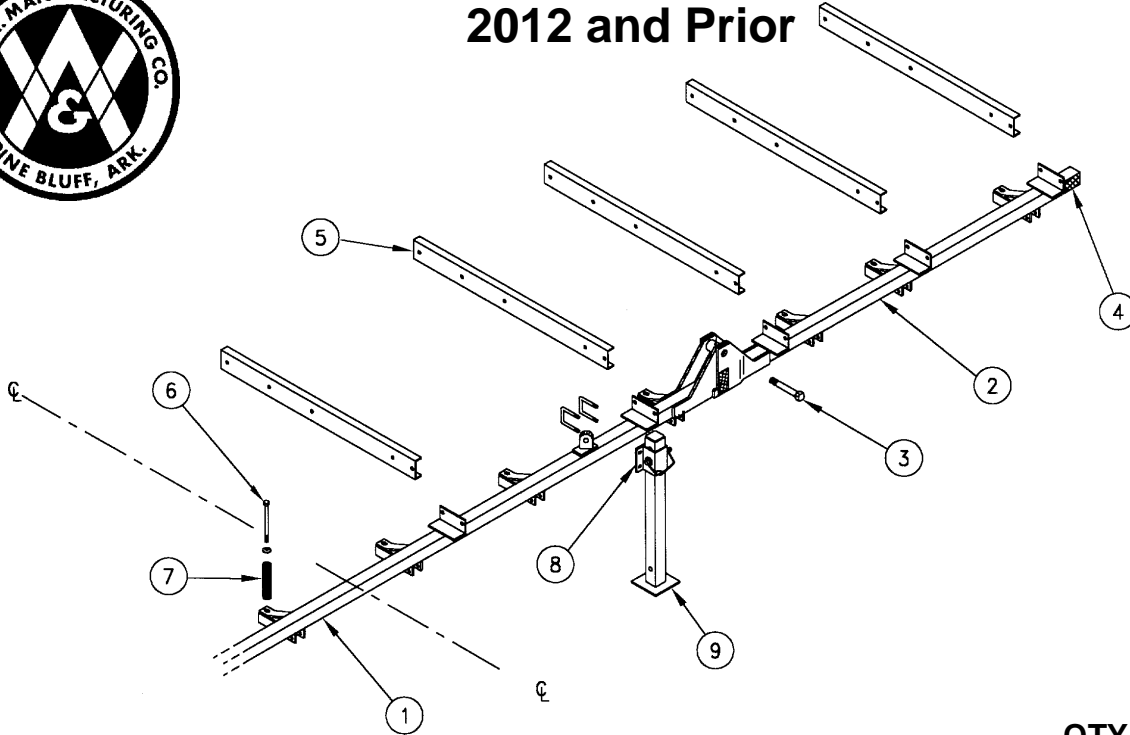

ITEM NO.	PART NO.	WT. LBS.	DESCRIPTION	QTY. REQ. FOR 1 MACHINE
1	302145	195	Rear Center Basket Frame(2½" Sq. Tube)	1
2	302146	101	Rear Wing Basket Frame - RH -- Shown....(2½" Sq.)	1
-	302147	101	Rear Wing Basket Frame - LH(2½" Sq.)	1
3	411668	3	Hex Bolt -- 1¼" x 6½" NC - Gr. 5 - Zinc	2
-	412420	½	Jam Nut -- 1¼" - 7 - Gr. 2 - Zinc	4
-	413117	-	Machine Washer -- 2¼" OD x 1¼" ID x 14 ga	4
4	461201	-	Decal -- Red Reflector - 4½" x 2"	4
5	204480	21½	Connecting Channel -- 4" x 48"	10
-	411560	-	Hex Bolt -- 5/8" x 1½" NC - Gr. 5 - Zinc	50
-	412010	-	Hex Nut -- 5/8" - 11 - Gr 2 - Zinc	50
-	413510	-	Lock Washer -- 5/8" - Zinc	50
6	411237	1	Hex Bolt -- 5/8" x 8" NC - Gr. 2 - Zinc	12
-	202350	-	Cup Washer for Spring.....(5/8")	12
-	410009	-	Lock Nut -- 5/8" NC - Zinc	12
7	471006	1½	Compression Spring.....(7" Coil)	12
8	301855	6	Holder - Rear Parking Stand for 2½" Sq. Tube	2
-	415108	½	1/2" U-Bolt x 2½" x 4" Leg - Grade 5.....	4
-	412008	-	Hex Nut -- 1/2" - 13 - Gr. 2 - Zinc	8
-	413508	-	Lock Washer -- 1/2" - Zinc.....	8
-	416230	¾	3/4" Safety Lock Pin x 5-1/2" OAL - Zinc	2
9	301856	22	Parking Stand Leg (2½" Sq. Tube x 31½")	2

ROLLING BASKETS

1½" Shaft and Bearings

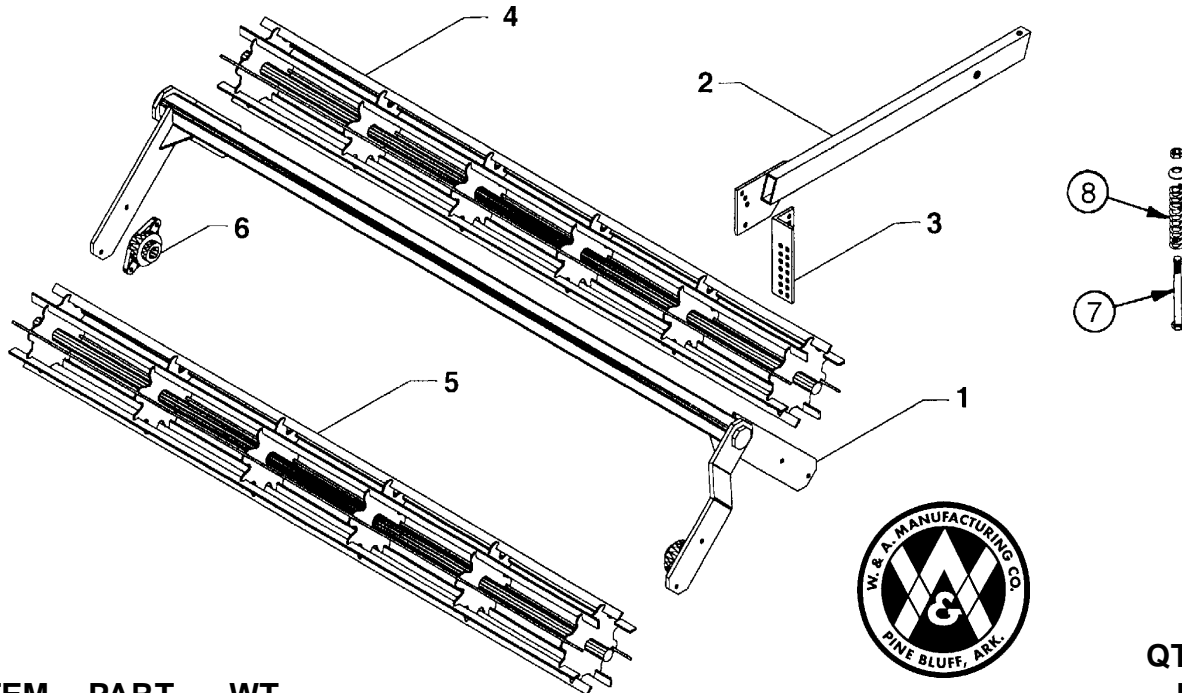

ITEM NO.	PART NO.	WT. LBS.	DESCRIPTION	QTY. REQ. FOR 1 MACHINE
1	301968	101	Two Basket Frame -- 1½" Brg. - 3 @ 30" Row	4
2	301290	20½	Arm -- Rolling Basket.....	12
-	411551	-	Hex Bolt -- 1/2" x 3" - Gr. 5 - Zinc	12
-	410008	-	Lock Nut -- 1/2" NC - Zinc.....	12
3	202729	5½	Connecting Angle -- Rolling Basket	12
-	411546	-	Hex Bolt -- 1/2" x 1¾" NC - Gr. 5 - Zinc	24
-	415108	½	1/2" U-Bolt x 2-1/2" x 4" Leg - Grade 5	24
-	410008	-	Lock Nut -- 1/2" NC - Zinc.....	72
4	301966	110	88" Front Basket Only -- 1½" Brg. - 3 @ 30" Row	4
5	301967	110	88" Rear Basket Only -- 1½" Brg. - 3 @ 30" Row	4
6	507081	3¼	1½" Cast Flange Bearing Assembly	16
-	411546	-	Hex Bolt -- 1/2" x 1-3/4" NC - Gr. 5 - Zinc.....	32
-	410008	-	Lock Nut -- 1/2" NC - Zinc	32
7	411237	1	Hex Bolt -- 5/8" x 8" NC - Gr. 2 - Zinc.....	12
-	200412	-	Formed Head Holder.....	12
-	410009	-	Lock Nut -- 5/8" NC - Zinc.....	12
-	202350	-	Cup Washer for Spring	12
8	471006	1½	Compression Spring.....	12

HITCH ASSEMBLY

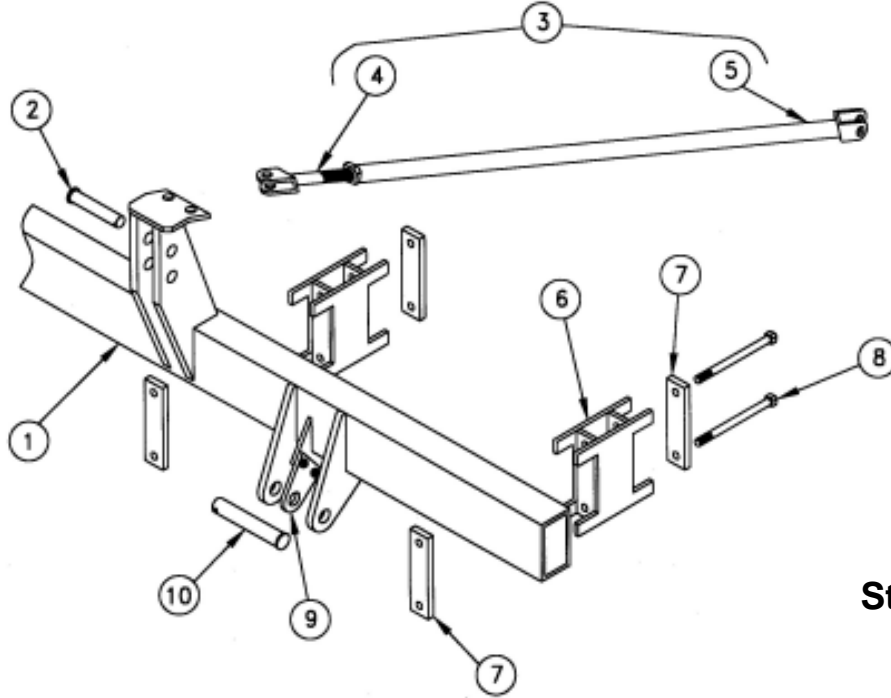

Cat. III
Standard or Narrow

ITEM NO.	PART NO.	WT. LBS.	DESCRIPTION	QTY. REQ. FOR 1 HITCH
1	302019	349	Hitch - 12 @ 30" Row - Cat. III & IIIN(4" x 7" x 114")...	1
2	416698	2	1 1/4" Top Link Pin - Zinc	1
-	416207	-	Klik Pin -- 7/16" - Zinc.....	1
3	773666	21 1/2	Adjusting Arm Assembly	2
-	416659	.70	Clevis Pin -- 1" x 2-21/32" - Zinc	4
-	416309	-	Rue Ring Cotter Pin 1" - Zinc	4
4	300381	5 1/4	Turnbuckle Bottom (Rod)	2
5	301602	16 1/4	Turnbuckle Body (65" Pipe)	2
6	302014	25	5" Spacer Block -- Top Leveling Stacker	4
7	203960	5	Backing Plate -- Top Leveling Stacker	8
-	411598	1/2	Hex Bolt -- 3/4" x 6 1/2" NC - Gr 5 - Zinc	8
-	412012	-	Hex Nut -- 3/4" - 10 - Gr 2 - Zinc	8
-	413512	-	Lock Washer -- 3/4" - Zinc.....	8
8	411604	1 1/4	Hex Bolt -- 3/4" x 10" NC - Gr 5 - Zinc.....	8
-	412012	-	Hex Nut -- 3/4" - 10 - Gr 2 - Zinc	8
-	413512	-	Lock Washer -- 3/4" - Zinc	8
9	204117	3	Hitch Center Pull Plate	2
-	411214	1/4	Hex Bolt -- 5/8" x 2" NC - Gr. 2 - Zinc.....	4
-	412010	-	Hex Nut -- 5/8" - 11 - Gr 2 - Zinc	4
-	413510	-	Lock Washer -- 5/8" - Zinc.....	4
10	300841	4 1/4	Hitch Pin -- 1-7/16" x 9"	2
-	416207	-	Klik Pin -- 7/16" - Zinc.....	2

363 - 12 Row 30" Folding Level Bander

RATCHET ADJ. GAUGE WHEELS



No. 1338
1 Pair Required

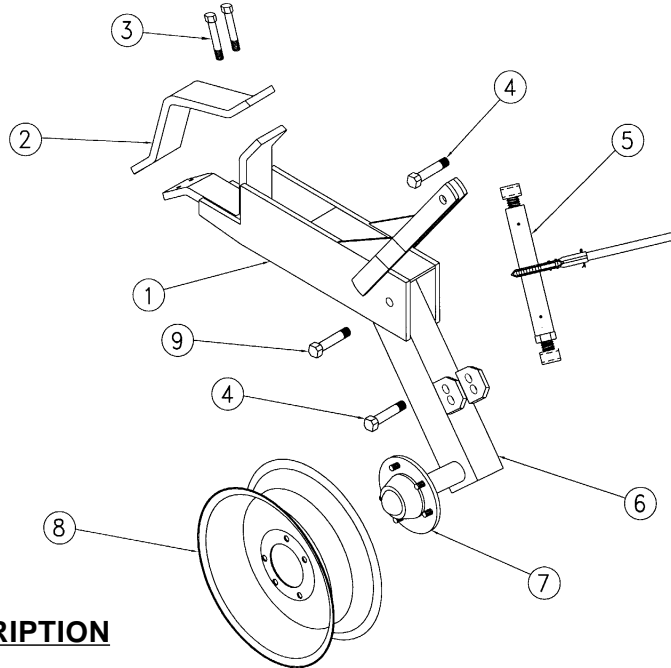

ITEM NO.	PART NO.	WT. LBS.	DESCRIPTION	QTY. REQ. FOR 1 ASSEMBLY
1	302225	60	Holder -- Gauge Wheels	1
2	203770	10	Backing Clamp for 7" Sq. Bar.....	1
3	411591	½	Hex Bolt -- 3/4" x 4" NC - Gr 5 - Zinc	4
-	412012	-	Hex Nut -- 3/4" - 10 - Gr 2 - Zinc.....(Not Illustrated) ...	4
-	413512	-	Lock Washer -- 3/4" - Zinc.....(Not Illustrated) ...	4
4	411591	½	Hex Bolt -- 3/4" x 4" NC - Gr 5 - Zinc	2
-	412012	-	Hex Nut -- 3/4" - 10 - Gr 2 - Zinc.....(Not Illustrated) ...	2
-	413512	-	Lock Washer -- 3/4" - Zinc.....(Not Illustrated) ...	2
5	302025	11½	Ratchet Crank Assembly	1
6	302226	34¾	RH Leg w/Hub -- #1338 Gauge Wheel	1
-	302227	34¾	LH Leg w/Hub -- #1338 Gauge Wheel.....(Not Illustrated) ...	1
7	491119	11	5 Hole Hub Complete - Q-719	1
-	491007	9¾	Hub w/Cups Only - Q-719.....(Not Illustrated) ...	1
-	481205	¼	Cone - Q809 & Q719 - LM67048.....(Not Illustrated) ...	1
-	496010	-	Outer Cup - Q809 & Q719 - LM67010.....(Not Illustrated) ...	1
-	481204	¼	Cone - Q809 & Q719 - LM48548.....(Not Illustrated) ...	1
-	496011	-	Inner Cup - Q809 & Q719 - LM48510.....(Not Illustrated) ...	1
-	497010	-	Grease Seal - Q719 - CR 15190.....(Not Illustrated) ...	1
-	490006	¼	Hub Cap - Q809 & Q719.....(Not Illustrated) ...	1
-	490015	-	1/2" NF Lug Nut.....(Not Illustrated) ...	5
-	490017	-	Drive-In Hub Bolt - Q719.....(Not Illustrated) ...	5
-	412164	-	Slotted Nut -- 7/8" - 14 Spindle.....(Not Illustrated) ...	1
-	490034	-	Spindle Washer -- 7/8" - Q875/Q809/Q719.....(Not Illustrated) ...	1
8	493007	17	15" x 5" x 5 Hole Wheel	1
9	411594	¾	Hex Bolt -- 3/4" x 5" NC - Gr 5 - Zinc	1
-	412012	-	Hex Nut -- 3/4" - 10 - Gr 2 - Zinc.....(Not Illustrated) ...	1
-	413512	-	Lock Washer -- 3/4" - Zinc.....(Not Illustrated) ...	1

BUSTER LEVEL BANDER 150° FOLDING

Model No. 3664 -- 12 @ 30" Row

3664 - 12 Row 30" Folding Buster Level Bander

REEL FRAME

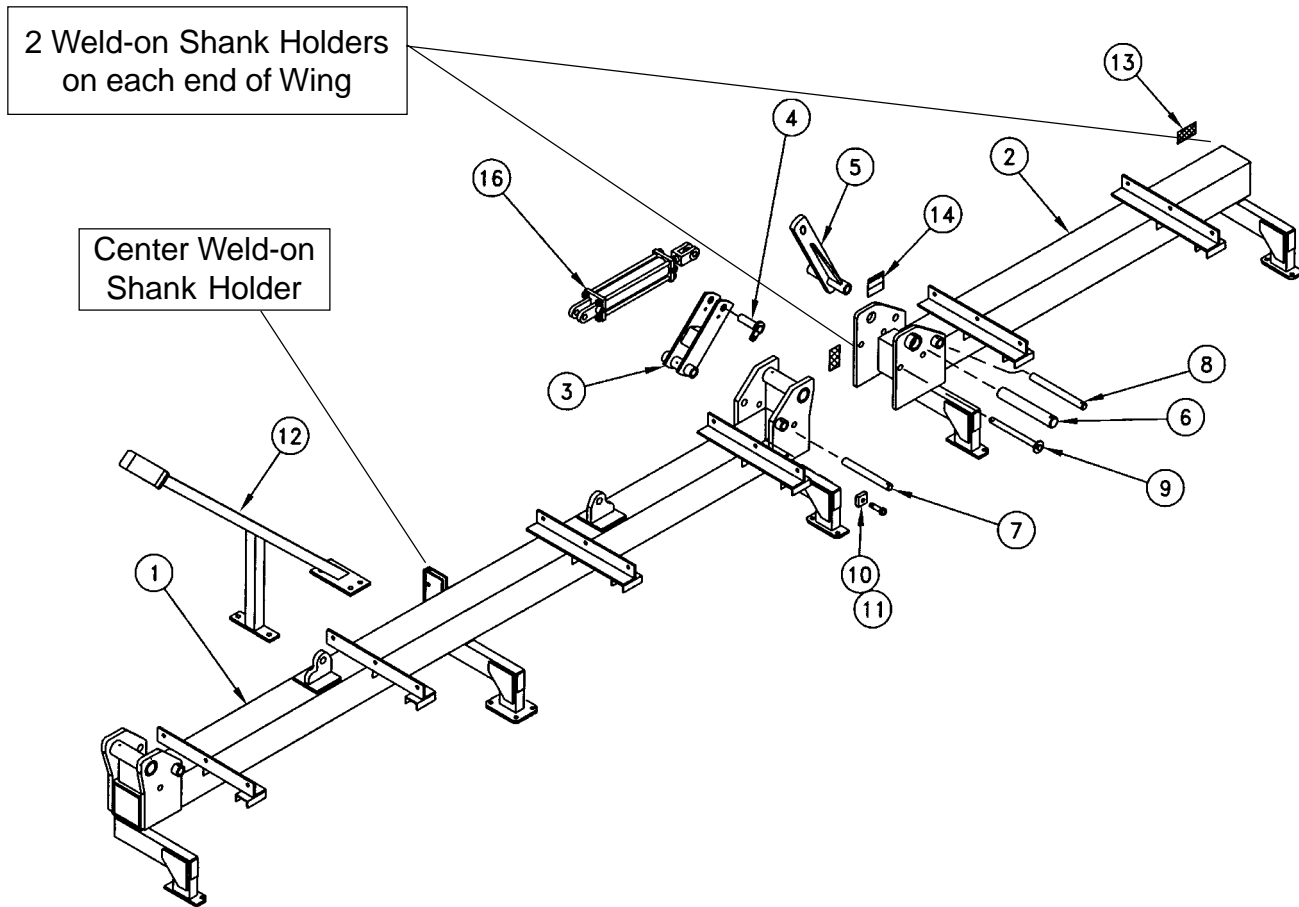

<u>ITEM NO.</u>	<u>PART NO.</u>	<u>WT. LBS.</u>	<u>DESCRIPTION</u>	<u>QTY. REQ.</u>
1	302142	810	Center Reel Frame	1
2	302143	371	Wing Reel Frame - RH (8 Row) - Shown	1
-	302144	371	Wing Reel Frame - LH (8 Row)	1
3	302085	21	Follow Arm - 150° Fold Bar	2
4	302086	2 ³ / ₄	Cylinder Lock Pin - 150° Fold Bar	2
-	411545	-	Hex Bolt -- 1/2" x 1-1/2" NC - Gr. 5 - Zinc	2
-	413008	-	Flat Washer -- 1/2" - Zinc	2
-	413508	-	Lock Washer -- 1/2" - Zinc.....	2
5	302084	23 ³ / ₄	Folding Arm - 150° Fold Bar	2
6	204388	11 ¹ / ₂	Pivot Pin -- 2" x 13-1/8" - 150° Fold Bar	2
-	416133	-	Roll Pin -- 1/2" x 3-1/2" - Zinc.....	2
7	204389	4	Follow Arm Pin -- 1 ¹ / ₄ " x 11 ¹ / ₂ " - 150° Fold Bar	2
-	416109	-	Roll Pin -- 5/16" x 2-1/2" - Zinc.....	4
8	204390	4 ¹ / ₂	Folding Arm Pin -- 1 ¹ / ₄ " x 13-1/8" - 150° Fold Bar	2

REEL FRAME

(Continued)

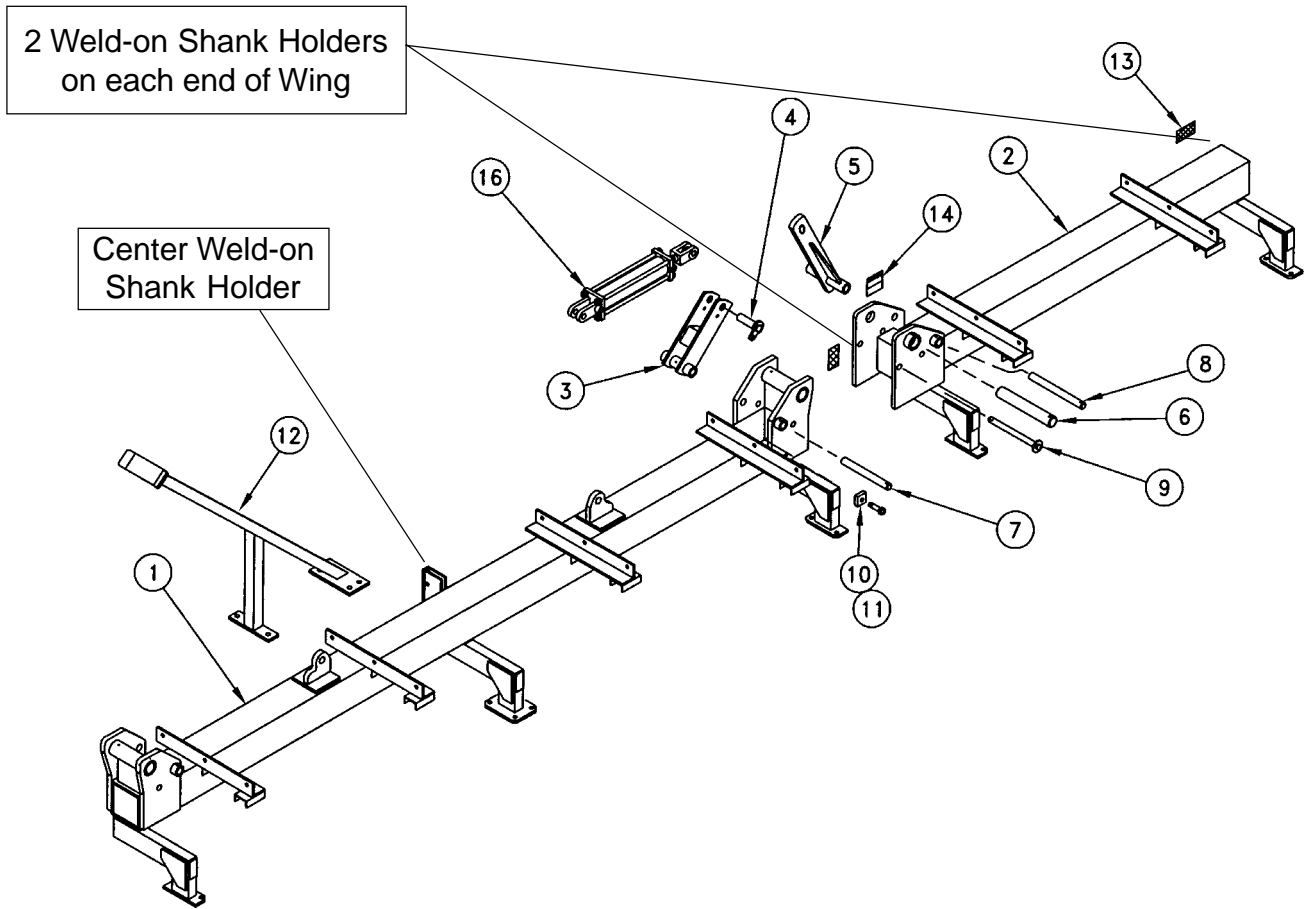

<u>ITEM NO.</u>	<u>PART NO.</u>	<u>WT. LBS.</u>	<u>DESCRIPTION</u>	<u>QTY. REQ.</u>
9	302087	3	Wing Lock Pin - 150° Fold Bar	2
-	416204	-	Klik Pin -- 1/4" - Zinc.....	2
10	204398	3/4	Stop Block - 150° Fold Bar	4
11	411584	1/4	Hex Bolt -- 3/4" x 2" NC - Gr. 5 - Zinc.....	4
-	413512	-	Lock Washer -- 3/4" - Zinc	4
12	302148	42	Wing Support Stand (48" Tube).....	2
-	415004	2½	3/4" Sq. U-Bolt x 7" x 9" Leg	6
-	412012	-	Hex Nut -- 3/4" - 10 - Gr. 2 - Zinc	12
-	413512	-	Lock Washer -- 3/4" - Zinc	12
13	461200	-	Decal -- Amber Reflector - 4½" x 2"(On Front of Wings)	4
14	461135	-	Warning Decal - "Overhead Wing Hazard"	2
15	476026	100	Hydraulic Cylinder -- 5" x 16"	2
-	446188	1/4	1/2" x 1/2" Swivel Orifice Elbow	4

REEL

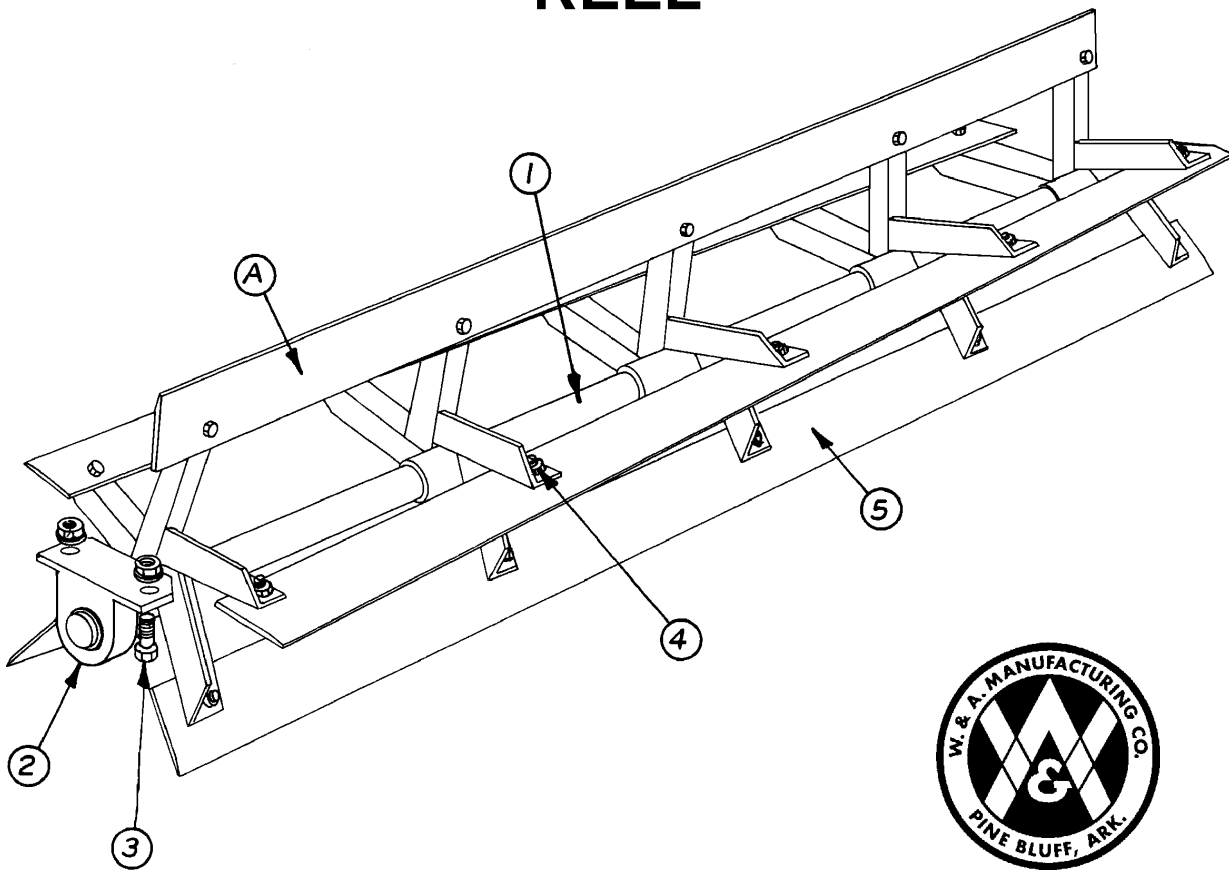

ITEM NO.	PART NO.	WT. LBS.	DESCRIPTION	QTY. REQ. FOR 1 MACHINE
A	770031	288	Spiral 84" Reel Complete w/Bearings	4
1	302149	152	89" Reel Shaft w/6 Support Brackets	4
2	482101	4	1-15/16" Pillow Block & Bearing Complete	8
-	481215	1	1-15/16" Bearing w/Lock Collar	-
-	480006	3	Pillow Block for 1-15/16" Bearing	-
3	411562	-	Hex Bolt -- 5/8" x 2 1/2" NC - Gr. 5 - Zinc	16
-	410009	-	Lock Nut -- 5/8" NC - Gr 2 - Zinc	16
-	413010	-	Flat Washer -- 5/8" - Zinc	16
4	411211	-	Hex Bolt -- 5/8" x 1 1/4" NC - Gr. 2 - Zinc	120
-	410009	-	Lock Nut -- 5/8" NC - Gr 2 - Zinc	120
5	204482	24 3/4	Spiral Pulvamer Blade x 84"	20

BOLT-ON SHANK HOLDERS

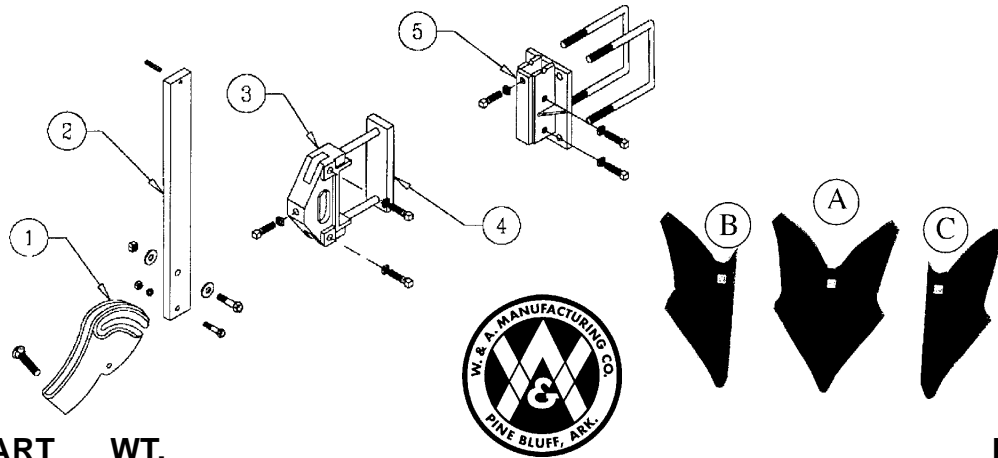

ITEM NO.	PART NO.	WT. LBS.	DESCRIPTION	QTY. REQ. FOR 12 ROW MACHINE
1	479075	6½	Friction Trip Foot	13
-	411549	-	Hex Bolt -- 1/2" x 2½" NC - Gr. 5 - Zinc	13
-	411563	½	Hex Bolt -- 5/8" x 3" NC - Gr. 5 - Zinc	13
-	411794	½	Carriage Bolt -- 3/4" x 3½" NC - Gr. 5 - Zinc	13
-	410009	-	Lock Nut -- 5/8" NC - Gr 2 - Zinc	13
-	410012	-	Lock Nut -- 3/4" NC - Gr 2 - Zinc	13
-	412008	-	Hex Nut -- 1/2" - 13 - Gr. 2 - Zinc	13
-	413056	-	Flat Washer, Heavy -- 5/8" - Zinc	26
-	413058	-	Flat Washer, Heavy -- 3/4" - Zinc	13
-	413508	-	Lock Washer -- 1/2" - Zinc	13
2	204210	25	Vertical Shank C1080	13
-	416120	-	Roll Pin -- 3/8" x 2" - Zinc	13
3	479069	13½	Bolt-On Shank Holder -- 7" Tool Bar	6
-	414828	-	Square Head Set Screw -- 5/8" x 1¾"	18
-	412310	-	Square Nut -- 5/8" - 11 - Gr. 2 - Zinc	18
-	412410	-	Jam Nut -- 5/8" - 11 - Gr. 2 - Zinc	18
4	204274	9	Backing Plate for Bolt-On Shank Holder - 7"	8
-	411601	1¼	Hex Bolt -- 3/4" x 8½" NC - Gr. 5 - Zinc	16
-	412012	-	Hex Nut -- 3/4" - 10 - Gr. 2 - Zinc	16
-	413512	-	Lock Washer -- 3/4" - Zinc	16
5	302036	19½	Center Bolt-On Shank Holder	2
-	415004	2½	3/4" Sq. U-Bolt x 7" x 9" Leg	4
-	412012	-	Hex Nut -- 3/4" - 10 - Gr. 2 - Zinc	8
-	413512	-	Lock Washer -- 3/4" - Zinc	8
-	414828	-	Square Head Set Screw -- 5/8" x 1¾"	21
-	412410	-	Jam Nut -- 5/8" - 11 - Gr 2 - Zinc	21
A	474031	7¼	#11N Furrower.....(11" Top Width)	11
B	204215		#11N End Furrower -- RH	1
C	204216		#11N End Furrower -- LH	1

NOTE: On 12@ 30" Row 150° Buster Level Bander -- FIVE Shank Holders are welded on frame.



BASKET FRAME

2013 and Later

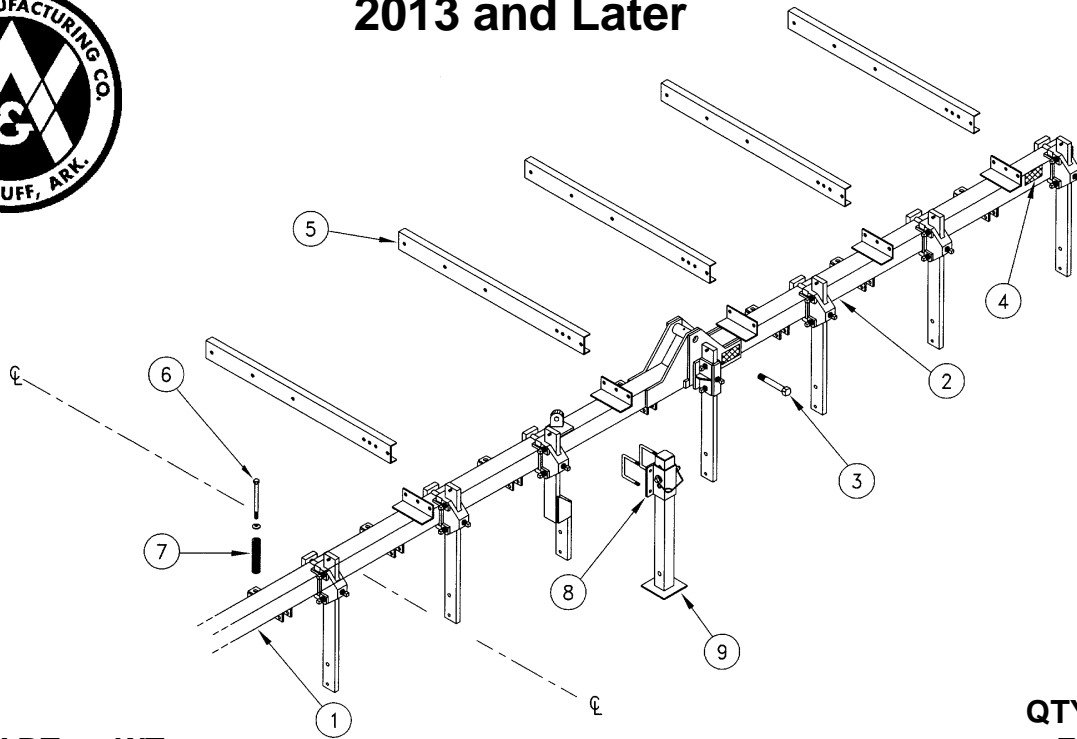

ITEM NO.	PART NO.	WT. LBS.	DESCRIPTION	QTY. REQ. FOR 1 MACHINE
1	302205	285	Rear Center Basket Frame (4" Sq. Tube)	1
2	302206	173	Rear Wing Basket Frame - RH (4" Sq.) -- Shown	1
-	302207	173	Rear Wing Basket Frame - LH (4" Sq.)	1
3	411671	3½	Hex Bolt -- 1¼" x 8" NC - Gr. 5 - Zinc	2
-	412420	½	Jam Nut -- 1¼" - 7 - Gr. 2 - Zinc	4
-	413117	-	Machine Washer -- 2¼" OD x 1¼" ID x 14 ga	4
4	461201	-	Decal -- Red Reflector - 4½" x 2"	4
5	204480	21½	Connecting Channel 48"	10
-	411560	-	Hex Bolt -- 5/8" x 1½" NC - Gr. 5 - Zinc	50
-	412010	-	Hex Nut -- 5/8" - 11 - Gr 2 - Zinc	50
-	413510	-	Lock Washer -- 5/8" - Zinc	50
6	411237	1	Hex Bolt -- 5/8" x 8" NC - Gr. 2 - Zinc	12
-	202350	-	Cup Washer for Spring.....(5/8")	12
-	410009	-	Lock Nut -- 5/8" NC - Gr 2 - Zinc	12
7	471006	1½	Compression Spring.....(7" Coil)	12
8	301860	7½	Parking Stand Bracket for 4" Sq. Tube	2
-	415010	1	5/8" Sq. U-Bolt x 4" x 5¼" Leg	4
-	412010	-	Hex Nut -- 5/8" - 11 - Gr. 2 - Zinc	8
-	413510	-	Lock Washer -- 5/8" - Zinc	8
-	416230	¾	3/4" Safety Lock Pin x 5½" OAL - Zinc.....	2
9	301856	22	Parking Stand Leg - 31½"	2

4" BOLT-ON SHANK HOLDER

Optional

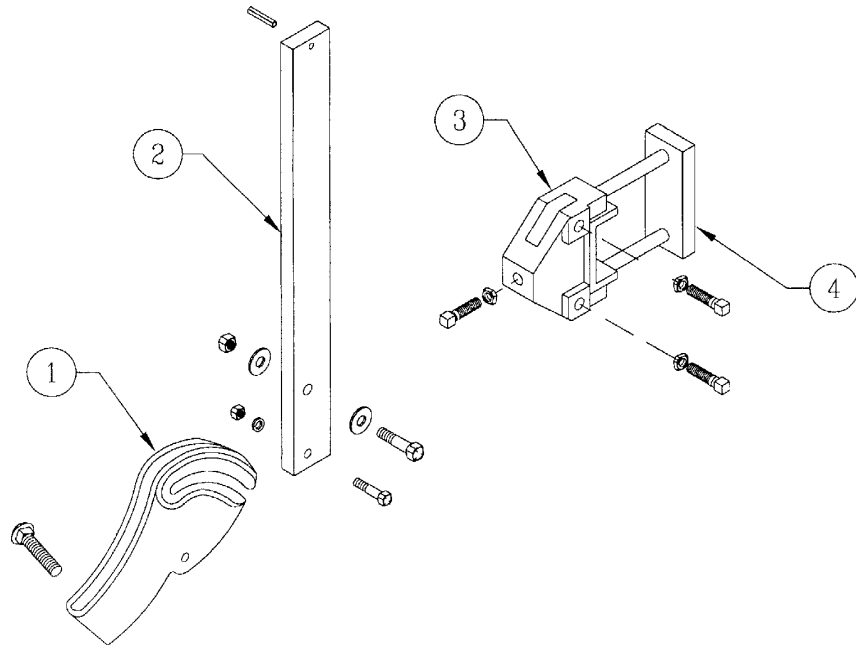

<u>ITEM NO.</u>	<u>PART NO.</u>	<u>WT. LBS.</u>	<u>DESCRIPTION</u>	<u>QTY. REQ'D</u>
1	479075	6½	Friction Trip Foot	13
-	411549	-	Hex Bolt -- 1/2" x 2½" NC - Gr. 5 - Zinc	13
-	411563	½	Hex Bolt -- 5/8" x 3" NC - Gr. 5 - Zinc	13
-	411794	½	Carriage Bolt -- 3/4" x 3½" NC - Gr. 5 - Zinc	13
-	410009	-	Lock Nut -- 5/8" NC - Gr 2 - Zinc	13
-	410012	-	Lock Nut -- 3/4" NC - Gr 2 - Zinc	13
-	412008	-	Hex Nut -- 1/2" - 13 - Gr. 2 - Zinc	13
-	413056	-	Flat Washer, Heavy -- 5/8" - Zinc	26
-	413058	-	Flat Washer, Heavy -- 3/4" - Zinc	26
-	413508	-	Lock Washer -- 1/2" - Zinc	13
2	204210	25	Vertical Shank C1080	11
-	302002	28	3" Offset Shank -- RH	1
-	302003	28	3" Offset SHank -- LH	1
-	416120	-	Roll Pin -- 3/8" x 2" - Zinc	13
3	479065	10¼	Bolt-On Shank Holder - 4" Tool Bar	11
-	414828	-	Square Head Set Screw -- 5/8" x 1¾"	39
-	412010	-	Hex Nut -- 5/8" - 11 - Gr 2 - Zinc	39
-	412410	-	Jam Nut -- 5/8" - 11 - Gr. 2 - Zinc	39
4	204275	6	Backing Plate for Bolt-On Shank Holder - 4"	11
-	411595	7¾	Hex Bolt -- 3/4" x 5½" - Gr. 5 - Zinc	22
-	412012	-	Hex Nut -- 3/4" - 10 - Gr. 2 - Zinc	22
-	413512	-	Lock Washer -- 3/4" - Zinc	22
N/I	474031	7¼	#11N Furrower	13

BASKET FRAME

2012 and Prior

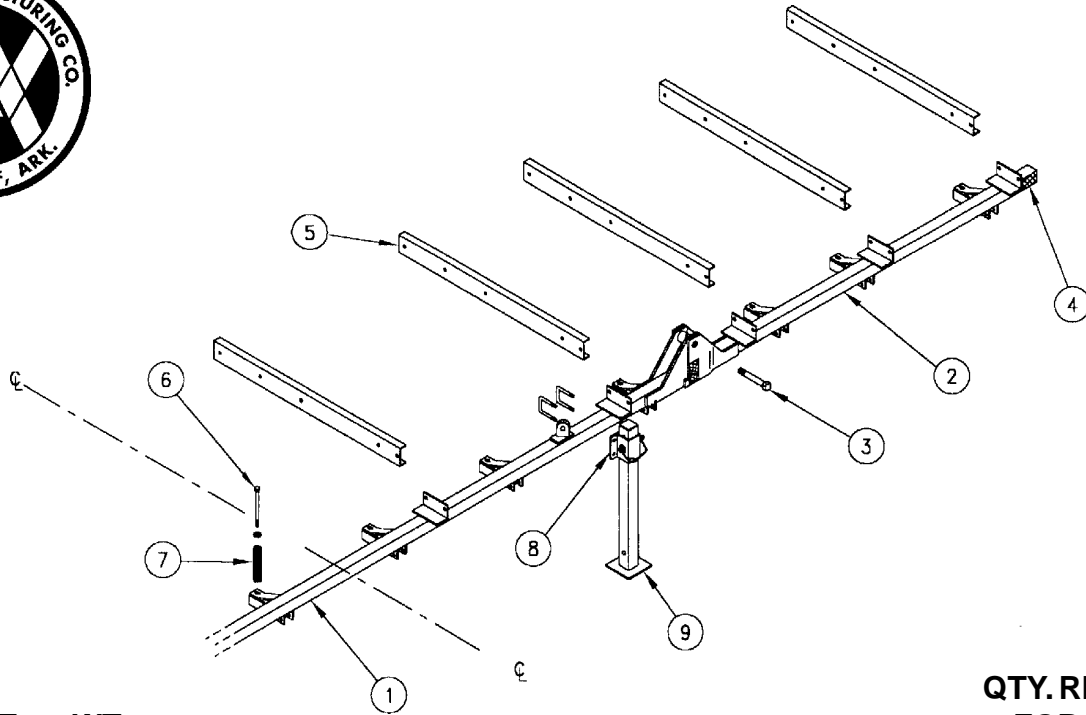

ITEM NO.	PART NO.	WT. LBS.	DESCRIPTION	QTY. REQ. FOR 1 MACHINE
1	302145	195	Rear Center Basket Frame (2½" Sq. Tube)	1
2	302146	101	Rear Wing Basket Frame - RH (2½" Sq.) -- Shown	1
-	302147	101	Rear Wing Basket Frame - LH (2½" Sq.)	1
3	411668	3	Hex Bolt -- 1¼" x 6½" NC - Gr. 5 - Zinc	2
-	412420	½	Jam Nut -- 1¼" - 7 - Gr. 2 - Zinc	4
-	413117	-	Machine Washer -- 2¼" OD x 1¼" ID x 14 ga	4
4	461201	-	Decal -- Red Reflector - 4½" x 2"	4
5	204480	21½	Connecting Channel 48"	10
-	411560	-	Hex Bolt -- 5/8" x 1½" NC - Gr. 5 - Zinc	50
-	412010	-	Hex Nut -- 5/8" - 11 - Gr 2 - Zinc	50
-	413510	-	Lock Washer -- 5/8" - Zinc	50
6	411237	1	Hex Bolt -- 5/8" x 8" NC - Gr. 2 - Zinc	12
-	202350	-	Cup Washer for Spring.....(5/8")	12
-	410009	-	Lock Nut -- 5/8" NC - Zinc	12
7	471006	1½	Compression Spring.....(7" Coil)	12
8	301855	6	Parking Stand Bracket	2
-	415108	½	1/2" U-Bolt x 2½" x 4" Leg - Grade 5	4
-	412008	-	Hex Nut -- 1/2" - 13 - Gr. 2 - Zinc	8
-	413508	-	Lock Washer -- 1/2" - Zinc	8
-	416230	¾	3/4" Safety Lock Pin x 5½" OAL - Zinc	2
9	301856	22	Parking Stand Leg	2

ROLLING BASKETS

1½" Shaft and Bearings

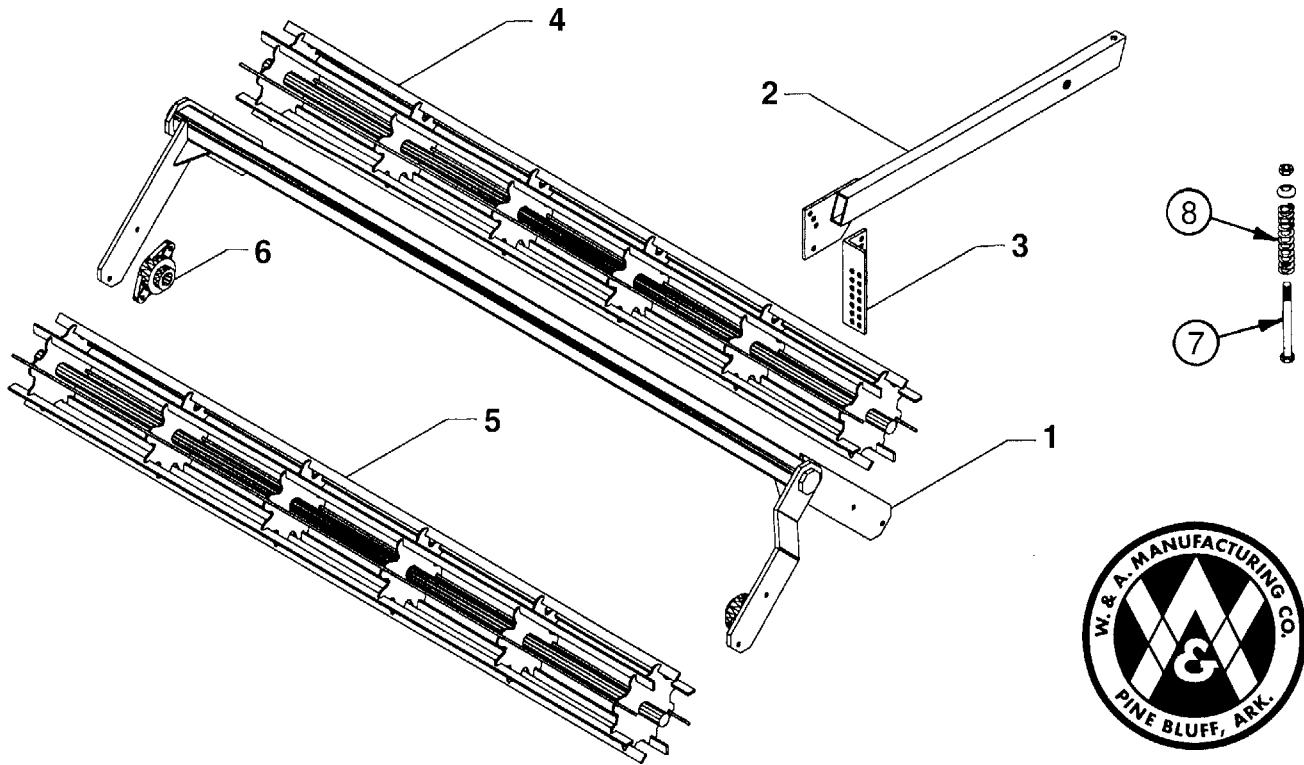

ITEM NO.	PART NO.	WT. LBS.	DESCRIPTION	QTY. REQ. FOR 1 MACHINE
1	301968	101	Six Basket Frame 30" -- 1½" Brg (3 row)	4
2	301290	20½	Arm -- Rolling Basket.....	12
-	411551	-	Hex Bolt -- 1/2" x 3" NC - Gr. 5 - Zinc	12
-	410008	-	Lock Nut -- 1/2" NC - Zinc	12
3	202729	5½	Connecting Angle -- Rolling Basket	12
-	411546	-	Hex Bolt -- 1/2" x 1¾" NC - Gr. 5 - Zinc.....	24
-	415108	½	1/2" U-Bolt x 2½" x 4" Leg - Grade 5	24
-	410008	-	Lock Nut -- 1/2" NC - Zinc.....	72
4	301966	110	88" Front Basket Only -- 1½" Brg. - 3 @ 30" Row	4
5	301967	110	88" Rear Basket Only -- 1½" Brg. - 3 @ 30" Row	4
6	507081	3¼	1½" Cast Flange Bearing Assembly	16
-	411546	-	Hex Bolt -- 1/2" x 1¾" NC - Gr. 5 - Zinc	32
-	410008	-	Lock Nut -- 1/2" NC - Zinc	32
7	411237	1	Hex Bolt -- 5/8" x 8" NC - Gr. 2 - Zinc	12
-	200412	-	Formed Head Holder	12
-	410009	-	Lock Nut -- 5/8" NC - Gr 2 - Zinc.....	12
-	202350	-	Cup Washer for Spring	12
8	471006	1½	Compression Spring.....	12

HITCH ASSEMBLY

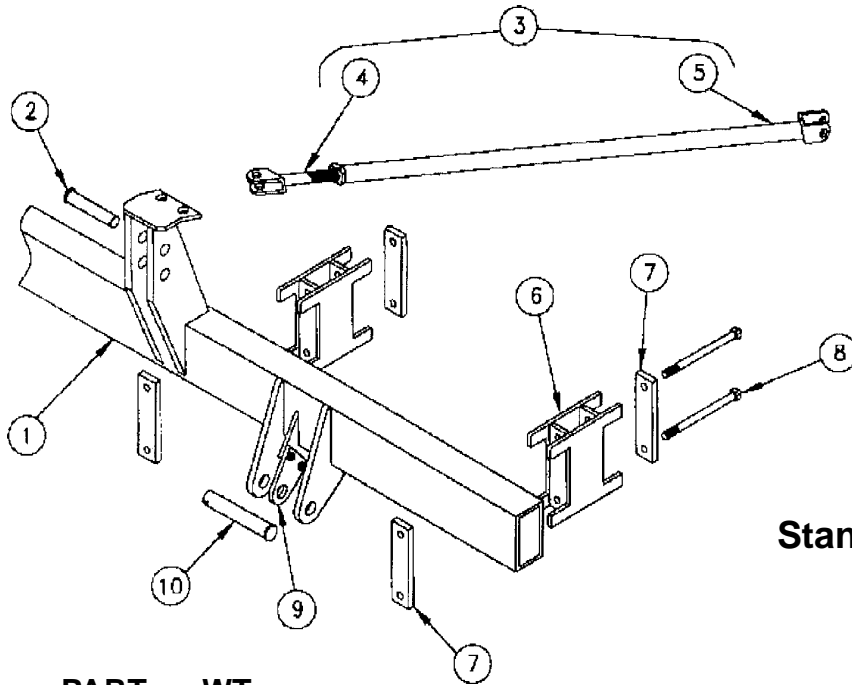

**Cat. III
Standard or Narrow**

ITEM NO.	PART NO.	WT. LBS.	DESCRIPTION	QTY. REQ. FOR 1 HITCH
1	302005	324	Hitch (102" Main Tube)	1
2	416698	2	1 1/4" Top Link Pin - Zinc	1
-	416207	-	Klik Pin -- 7/16" - Zinc	1
3	773666	21 1/2	Adjusting Arm Assembly	2
-	416659	.70	Clevis Pin -- 1" x 2-21/32" - Zinc	4
-	416309	-	Rue Ring Cotter Pin 1" - Zinc	4
4	300381	5 1/4	Turnbuckle Bottom (Rod)	2
5	301602	16 1/4	Turnbuckle Body (65" Pipe)	2
6	302014	25	5" Spacer Block -- Top Leveling Stacker	4
7	203960	5	Backing Plate -- Top Leveling Stacker	8
-	411598	1/2	Hex Bolt -- 3/4" x 6 1/2" NC - Gr 5 - Zinc	8
-	412012	-	Hex Nut -- 3/4" - 10 - Gr 2 - Zinc	8
-	413512	-	Lock Washer -- 3/4" - Zinc	8
8	411604	1 1/4	Hex Bolt -- 3/4" x 10" NC - Gr 5 - Zinc	8
-	412012	-	Hex Nut -- 3/4" - 10 - Gr 2 - Zinc	8
-	413512	-	Lock Washer -- 3/4" - Zinc	8
9	204117	3	Hitch Center Pull Plate	2
-	411214	1/4	Hex Bolt -- 5/8" x 2" NC - Gr 2 - Zinc	4
-	412010	-	Hex Nut -- 5/8" - 11 - Gr 2 - Zinc	4
-	413510	-	Lock Washer -- 5/8" - Zinc	4
10	300841	4 1/4	Hitch Pin -- 1-7/16" x 9"	2
-	416207	-	Klik Pin -- 7/16" - Zinc	2

RATCHET ADJ. GAUGE WHEELS

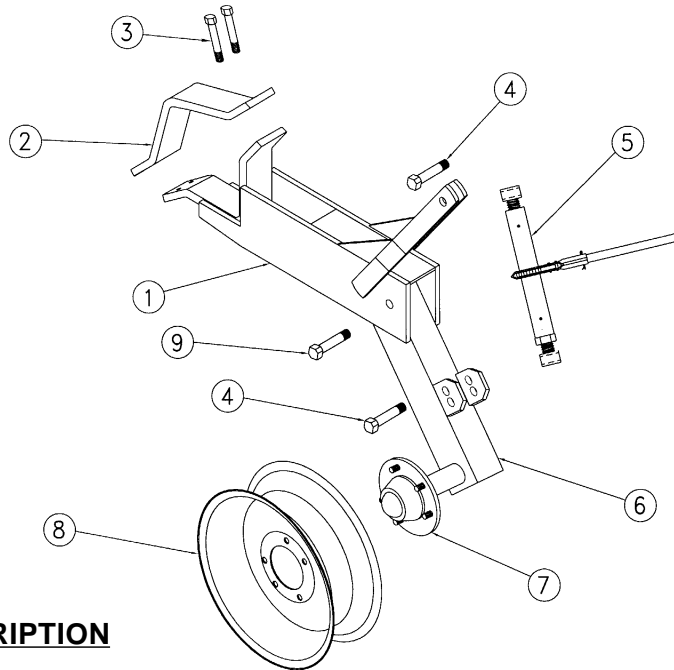

No. 1338
1 Pair Required

ITEM NO.	PART NO.	WT. LBS.	DESCRIPTION	QTY. REQ. FOR 1 ASSEMBLY
1	302225	60	Holder -- Gauge Wheels	1
2	203770	10	Backing Clamp for 7" Sq. Bar.....	1
3	411591	1/2	Hex Bolt -- 3/4" x 4" NC - Gr 5 - Zinc	4
-	412012	-	Hex Nut -- 3/4" - 10 - Gr 2 - Zinc.....(Not Illustrated) ...	4
-	413512	-	Lock Washer -- 3/4" - Zinc.....(Not Illustrated) ...	4
4	411591	1/2	Hex Bolt -- 3/4" x 4" NC - Gr 5 - Zinc	2
-	412012	-	Hex Nut -- 3/4" - 10 - Gr 2 - Zinc.....(Not Illustrated) ...	2
-	413512	-	Lock Washer -- 3/4" - Zinc.....(Not Illustrated) ...	2
5	302025	11 1/2	Ratchet Crank Assembly	1
6	302226	34 3/4	RH Leg w/Hub -- #1338 Gauge Wheel	1
-	302227	34 3/4	LH Leg w/Hub -- #1338 Gauge Wheel.....(Not Illustrated) ...	1
7	491119	11	5 Hole Hub Complete - Q-719	1
-	491007	9 3/4	Hub w/Cups Only - Q-719.....(Not Illustrated) ...	1
-	481205	1/4	Cone - Q809 & Q719 - LM67048.....(Not Illustrated) ...	1
-	496010	-	Outer Cup - Q809 & Q719 - LM67010.....(Not Illustrated) ...	1
-	481204	1/4	Cone - Q809 & Q719 - LM48548.....(Not Illustrated) ...	1
-	496011	-	Inner Cup - Q809 & Q719 - LM48510.....(Not Illustrated) ...	1
-	497010	-	Grease Seal - Q719 - CR 15190.....(Not Illustrated) ...	1
-	490006	1/4	Hub Cap - Q809 & Q719.....(Not Illustrated) ...	1
-	490015	-	1/2" NF Lug Nut.....(Not Illustrated) ...	5
-	490017	-	Drive-In Hub Bolt - Q719.....(Not Illustrated) ...	5
-	412164	-	Slotted Nut -- 7/8" - 14 Spindle.....(Not Illustrated) ...	1
-	490034	-	Spindle Washer -- 7/8" - Q875/Q809/Q719.....(Not Illustrated) ...	1
8	493007	17	15" x 5" x 5 Hole Wheel	1
9	411594	3/4	Hex Bolt -- 3/4" x 5" NC - Gr 5 - Zinc	1
-	412012	-	Hex Nut -- 3/4" - 10 - Gr 2 - Zinc.....(Not Illustrated) ...	1
-	413512	-	Lock Washer -- 3/4" - Zinc.....(Not Illustrated) ...	1

BUSTER/CRUMBLER LEVEL BANDER

Model No. 3684 -- 12 @ 30" - 150° Folding

REEL FRAME

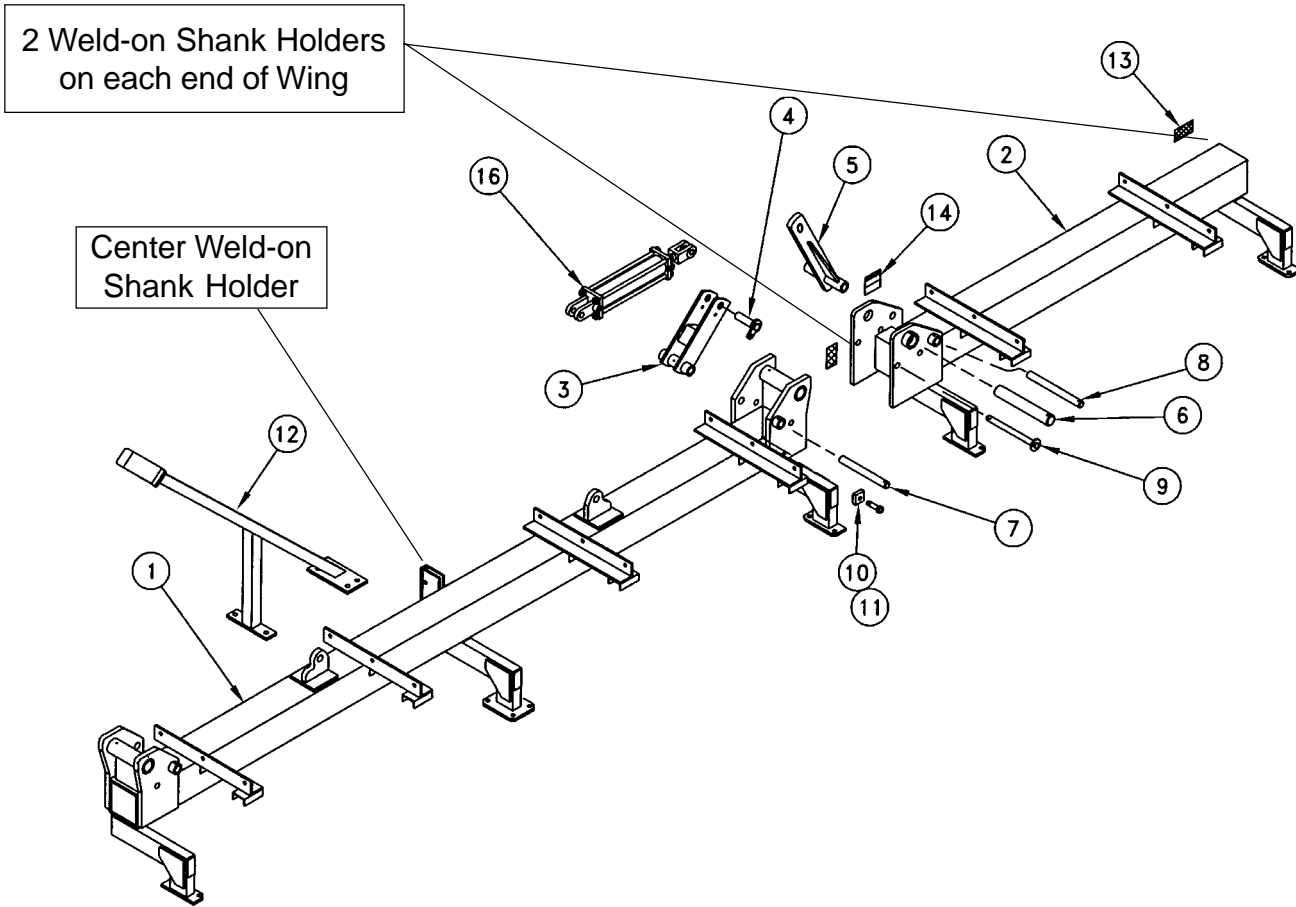

<u>ITEM NO.</u>	<u>PART NO.</u>	<u>WT. LBS.</u>	<u>DESCRIPTION</u>	<u>QTY. REQ.</u>
1	302142	810	Center Reel Frame	1
2	302143	371	Wing Reel Frame - RH (8 Row) - Shown	1
-	302144	371	Wing Reel Frame - LH (8 Row)	1
3	302085	21	Follow Arm - 150° Fold Bar	2
4	302086	2 ³ / ₄	Cylinder Lock Pin - 150° Fold Bar	2
-	411545	-	Hex Bolt -- 1/2" x 1-1/2" NC - Gr. 5 - Zinc	2
-	413008	-	Flat Washer -- 1/2" - Zinc	2
-	413508	-	Lock Washer -- 1/2" - Zinc.....	2
5	302084	23 ³ / ₄	Folding Arm - 150° Fold Bar	2
6	204388	11 ¹ / ₂	Pivot Pin -- 2" x 13-1/8" - 150° Fold Bar	2
-	416133	-	Roll Pin -- 1/2" x 3-1/2" - Zinc.....	2
7	204389	4	Follow Arm Pin -- 1 ¹ / ₄ " x 11 ¹ / ₂ " - 150° Fold Bar	2
-	416109	-	Roll Pin -- 5/16" x 2-1/2" - Zinc.....	4
8	204390	4 ¹ / ₂	Folding Arm Pin -- 1 ¹ / ₄ " x 13-1/8" - 150° Fold Bar	2

REEL FRAME

(Continued)

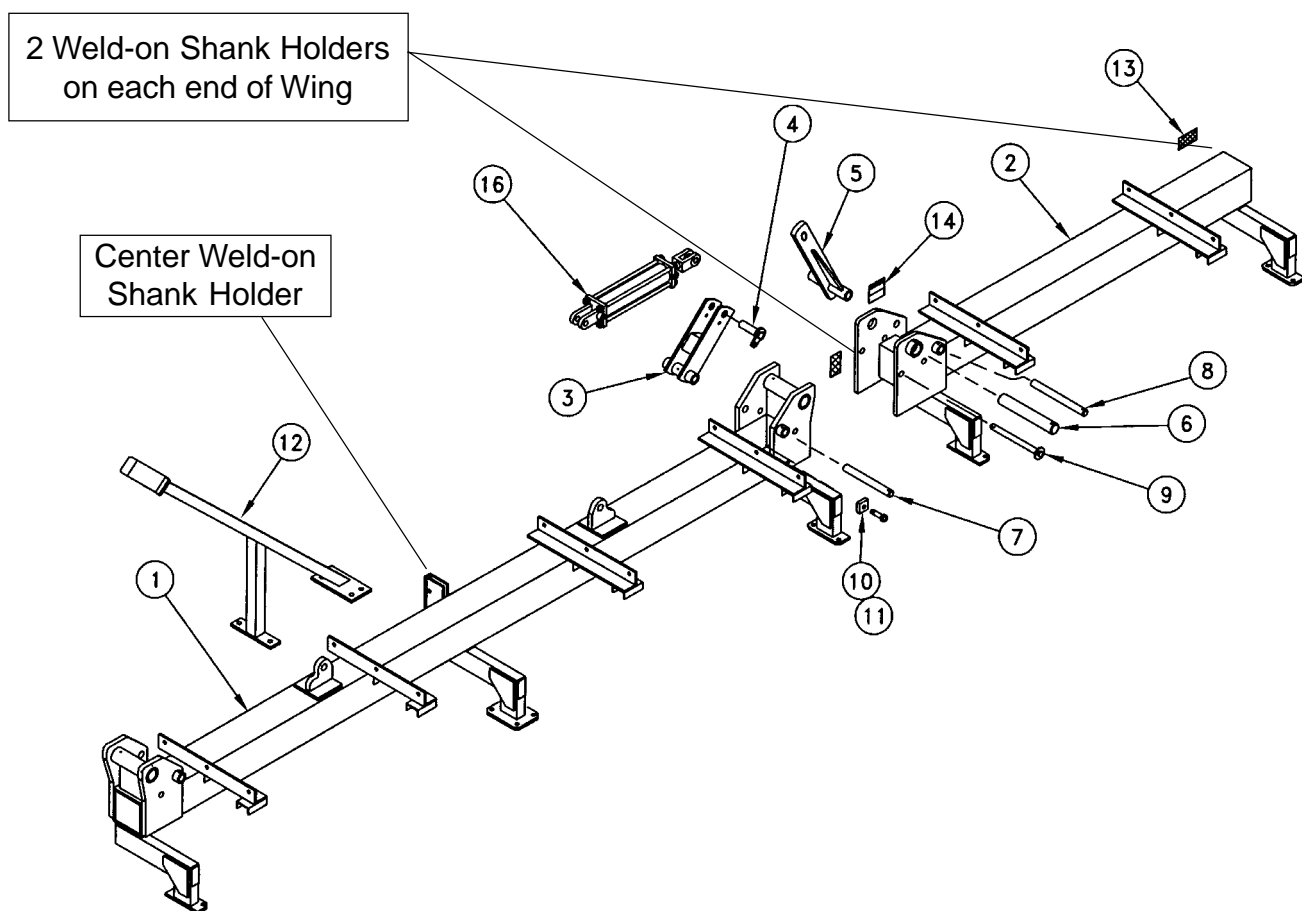

<u>ITEM NO.</u>	<u>PART NO.</u>	<u>WT. LBS.</u>	<u>DESCRIPTION</u>	<u>QTY. REQ.</u>
9	302087	3	Wing Lock Pin - 150° Fold Bar	2
-	416204	-	Klik Pin -- 1/4" - Zinc.....	2
10	204398	3/4	Stop Block - 150° Fold Bar	4
11	411584	1/4	Hex Bolt -- 3/4" x 2" NC - Gr. 5 - Zinc.....	4
-	413512	-	Lock Washer -- 3/4" - Zinc	4
12	302148	42	Wing Support Stand (48" Tube).....	2
-	415004	2½	3/4" Sq. U-Bolt x 7" x 9" Leg	6
-	412012	-	Hex Nut -- 3/4" - 10 - Gr. 2 - Zinc	12
-	413512	-	Lock Washer -- 3/4" - Zinc	12
13	461200	-	Decal -- Amber Reflector - 4½" x 2"(On Front of Wings)	4
14	461135	-	Warning Decal - "Overhead Wing Hazard"	2
15	476026	100	Hydraulic Cylinder -- 5" x 16"	2
-	446188	1/4	1/2" x 1/2" Swivel Orifice Elbow	4

DIAMOND CRUMBLER REEL

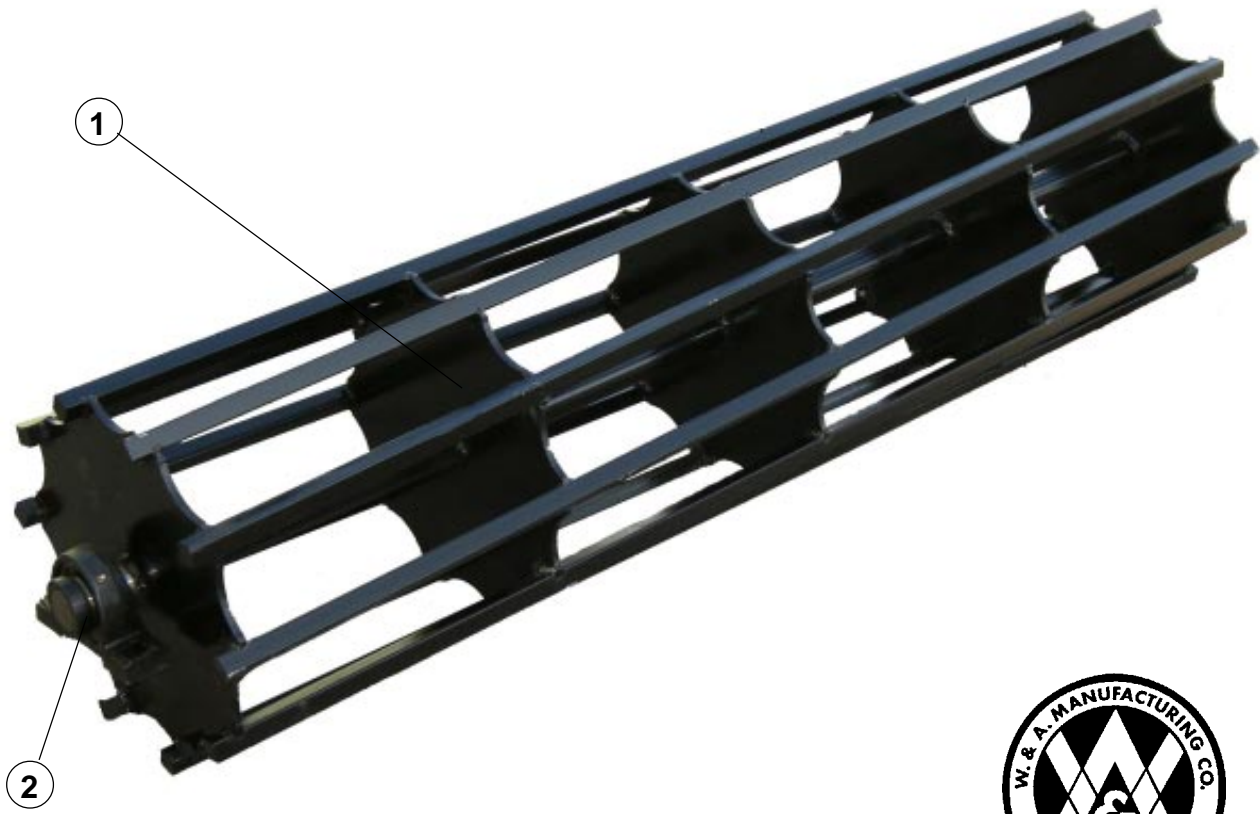

<u>ITEM NO.</u>	<u>PART NO.</u>	<u>WT. LBS.</u>	<u>DESCRIPTION</u>	<u>QTY. REQ. FOR 1 MACHINE</u>
1	770082	440	84" Dia. Crumbler Reel Complete w/Bearings	4
-	302303	432	84" Diamond Crumbler Reel Only	4
2	482101	4	1-15/16" Pillow Block & Bearing Complete	8
-	481215	1	1-15/16" Bearing w/Lock Collar	-
-	480006	3	Pillow Block for 1-15/16" Bearing	-
-	411562	-	Hex Bolt -- 5/8" x 2½" NC - Gr. 5 - Zinc	16
-	410009	-	Lock Nut -- 5/8" NC - Gr 2 - Zinc	16
-	413010	-	Flat Washer -- 5/8" - Zinc	16

BOLT-ON SHANK HOLDERS

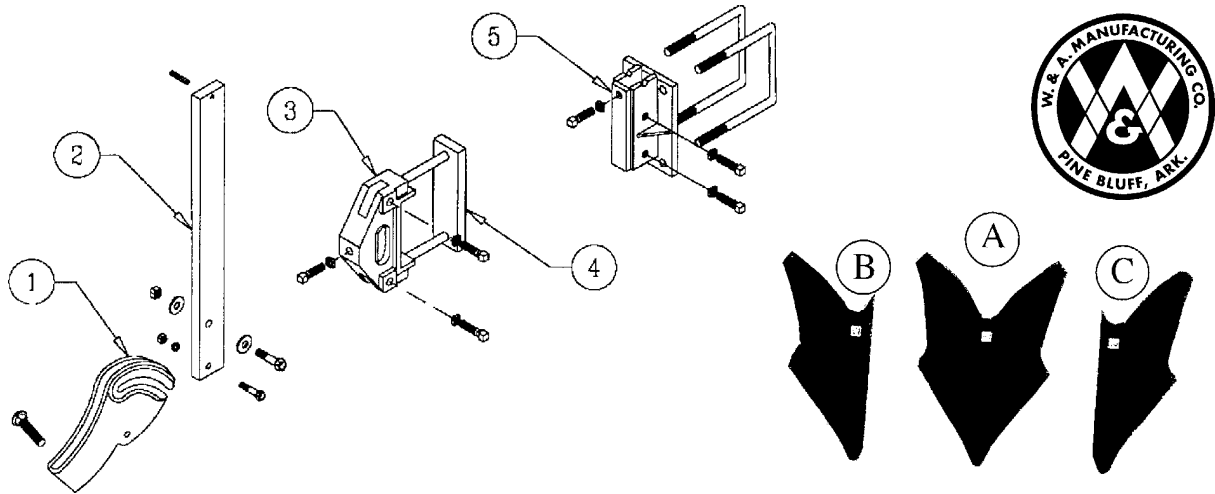

<u>ITEM NO.</u>	<u>PART NO.</u>	<u>WT. LBS.</u>	<u>DESCRIPTION</u>	<u>QTY. REQ. FOR 12 ROW MACHINE</u>
1	479075	6½	Friction Trip Foot	13
-	411549	-	Hex Bolt -- 1/2" x 2½" NC - Gr. 5 - Zinc.....	13
-	411563	½	Hex Bolt -- 5/8" x 3" NC - Gr. 5 - Zinc.....	13
-	411794	½	Carriage Bolt -- 3/4" x 3½" NC - Gr. 5 - Zinc	13
-	410009	-	Lock Nut -- 5/8" NC - Gr. 2 - Zinc	13
-	410012	-	Lock Nut -- 3/4" NC - Gr. 2 - Zinc	13
-	412008	-	Hex Nut -- 1/2" - 13 - Gr. 2 - Zinc	13
-	413056	-	Flat Washer, Heavy -- 5/8" - Zinc	26
-	413058	-	Flat Washer, Heavy -- 3/4" - Zinc	13
-	413508	-	Lock Washer -- 1/2" - Zinc.....	13
2	204210	25	Vertical Shank C1080	13
-	416120	-	Roll Pin -- 3/8" x 2" - Zinc	13
3	479069	13½	Bolt-On Shank Holder -- 7" Tool Bar	6
-	414828	-	Square Head Set Screw -- 5/8" x 1¼"	18
-	412310	-	Square Nut -- 5/8" - 11 - Gr. 2 - Zinc.....	18
-	412410	-	Jam Nut -- 5/8" - 11 - Gr. 2 - Zinc	18
4	204274	9	Backing Plate for Bolt-On Shank Holder - 7"	8
-	411601	1¼	Hex Bolt -- 3/4" x 8½" NC - Gr. 5 - Zinc.....	16
-	412012	-	Hex Nut -- 3/4" - 10 - Gr. 2 - Zinc	16
-	413512	-	Lock Washer -- 3/4" - Zinc.....	16
5	302036	19½	Center Bolt-On Shank Holder	2
-	415004	2½	3/4" Sq. U-Bolt x 7" x 9" Leg	4
-	412012	-	Hex Nut -- 3/4" - 10 - Gr. 2 - Zinc	8
-	413512	-	Lock Washer -- 3/4" - Zinc.....	8
-	414828	-	Square Head Set Screw -- 5/8" x 1¼"	21
-	412410	-	Jam Nut -- 5/8" - 11 - Gr 2 - Zinc.....	21
A	474031	7¼	#11N Furrower.....(11" Top Width)	11
B	204215		#11N End Furrower -- RH	1
C	204216		#11N End Furrower -- LH	1

NOTE: On 12@ 30" Row 150° Buster/Crumbler Level Bander -- FIVE Shank Holders are welded on frame.



BASKET FRAME

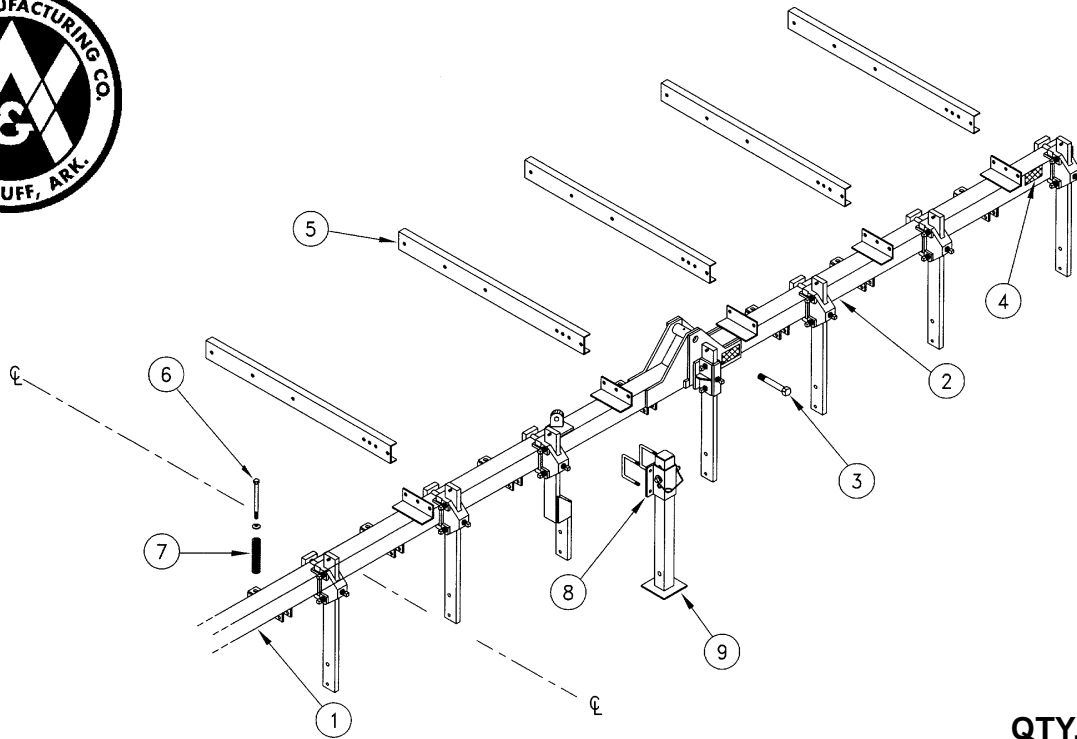

ITEM NO.	PART NO.	WT. LBS.	DESCRIPTION	QTY. REQ. FOR 1 MACHINE
1	302205	285	Rear Center Basket Frame (4" Sq. Tube)	1
2	302206	173	Rear Wing Basket Frame - RH (4" Sq.) -- Shown	1
-	302207	173	Rear Wing Basket Frame - LH (4" Sq.)	1
3	411671	3½	Hex Bolt -- 1¼" x 8" NC - Gr. 5 - Zinc.....	2
-	412420	½	Jam Nut -- 1¼" - 7 - Gr. 2 - Zinc	4
-	413117	-	Machine Washer -- 2¼" OD x 1¼" ID x 14 ga	4
4	461201	-	Decal -- Red Reflector - 4½" x 2".....	4
5	204480	21½	Connecting Channel 48"	10
-	411560	-	Hex Bolt -- 5/8" x 1½" NC - Gr. 5 - Zinc	50
-	412010	-	Hex Nut -- 5/8" - 11 - Gr 2 - Zinc	50
-	413510	-	Lock Washer -- 5/8" - Zinc.....	50
6	411237	1	Hex Bolt -- 5/8" x 8" NC - Gr. 2 - Zinc.....	12
-	202350	-	Cup Washer for Spring.....(5/8").....	12
-	410009	-	Lock Nut -- 5/8" NC - Zinc	12
7	471006	1½	Compression Spring.....(7" Coil)	12
8	301860	7½	Parking Stand Bracket for 4" Sq. Tube	2
-	415010	1	5/8" U-Bolt x 4" x 5¼" Leg	4
-	412010	-	Hex Nut -- 5/8" - 11 - Gr. 2 - Zinc	8
-	413510	-	Lock Washer -- 5/8" - Zinc.....	8
-	416230	¾	3/4" Safety Lock Pin x 5-1/2" OAL - Zinc	2
9	301856	22	Parking Stand Leg -- 31½"	2

4" BOLT-ON SHANK HOLDER

Optional

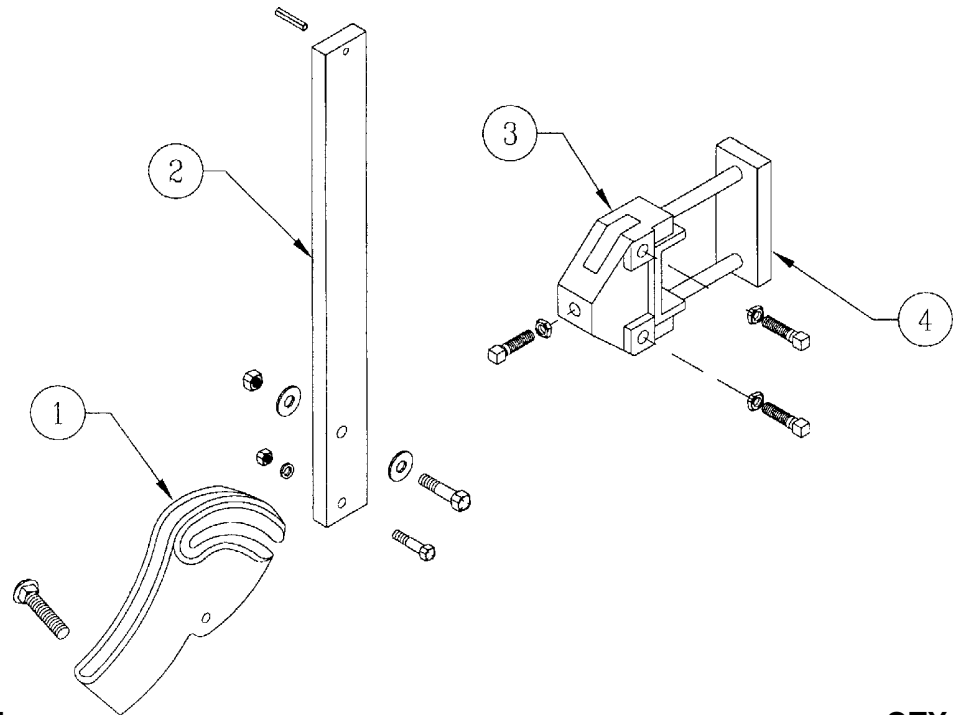

<u>ITEM NO.</u>	<u>PART NO.</u>	<u>WT. LBS.</u>	<u>DESCRIPTION</u>	<u>QTY. REQ'D</u>
1	479075	6½	Friction Trip Foot	13
-	411549	-	Hex Bolt -- 1/2" x 2½" NC - Gr. 5 - Zinc	13
-	411563	½	Hex Bolt -- 5/8" x 3" NC - Gr. 5 - Zinc	13
-	411794	½	Carriage Bolt -- 3/4" x 3½" NC - Gr. 5 - Zinc	13
-	410009	-	Lock Nut -- 5/8" NC - Gr. 2 - Zinc	13
-	410012	-	Lock Nut -- 3/4" NC - Gr. 2 - Zinc	13
-	412008	-	Hex Nut -- 1/2" - 13 - Gr. 2 - Zinc	13
-	413056	-	Flat Washer, Heavy -- 5/8" - Zinc	26
-	413058	-	Flat Washer, Heavy -- 3/4" - Zinc	26
-	413508	-	Lock Washer -- 1/2" - Zinc	13
2	204210	25	Vertical Shank C1080	11
-	302002	28	3" Offset Shank -- RH	1
-	302003	28	3" Offset SHank -- LH	1
-	416120	-	Roll Pin -- 3/8" x 2" - Zinc	13
3	479065	10¼	Bolt-On Shank Holder - 4" Tool Bar	11
-	414828	-	Square Head Set Screw -- 5/8" x 1¾"	39
-	412010	-	Hex Nut -- 5/8" - 11 - Gr. 2 - Zinc	39
-	412410	-	Jam Nut -- 5/8" - 11 - Gr. 2 - Zinc	39
4	204275	6	Backing Plate for Bolt-On Shank Holder - 4"	11
-	411595	7¾	Hex Bolt -- 3/4" x 5½" NC - Gr. 5 - Zinc	22
-	412012	-	Hex Nut -- 3/4" - 10 - Gr. 2 - Zinc	22
-	413512	-	Lock Washer -- 3/4" - Zinc	22
N/I	474031	7¼	#11N Furrower	13

ROLLING BASKETS

1½" Shaft and Bearings

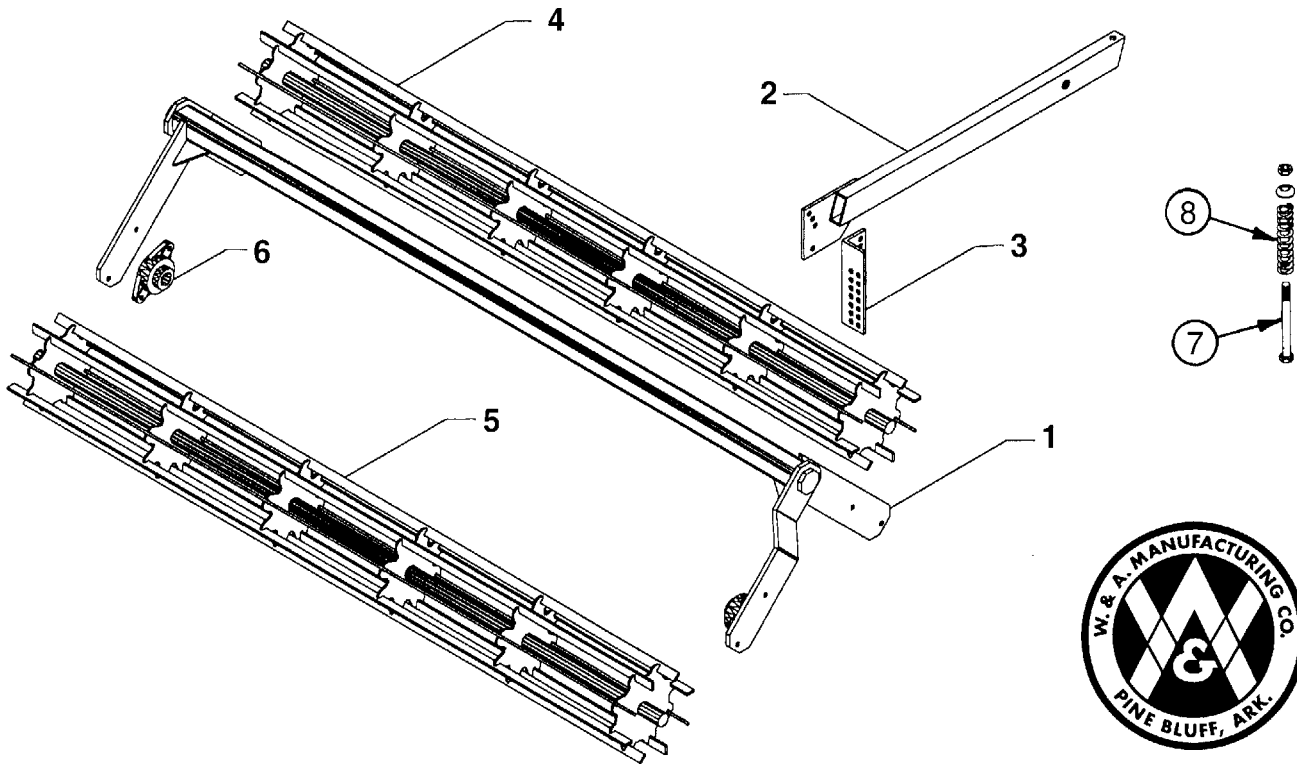

ITEM NO.	PART NO.	WT. LBS.	DESCRIPTION	QTY. REQ. FOR 1 MACHINE
1	301968	101	Six Basket Frame 30" -- 1½" Brg. (3 row)	4
2	301290	20½	Arm -- Rolling Basket	12
-	411551	-	Hex Bolt -- 1/2" x 3" NC - Gr. 5 - Zinc	12
-	410008	-	Lock Nut -- 1/2" NC - Zinc	12
3	202729	5½	Connecting Angle -- Rolling Basket	12
-	411546	-	Hex Bolt -- 1/2" x 1¾" NC - Gr. 5 - Zinc	24
-	415108	½	1/2" U-Bolt x 2½" x 4" Leg - Grade 5	24
-	410008	-	Lock Nut -- 1/2" NC - Zinc	72
4	301966	110	88" Front Basket Only -- 1½" Brg. - 3 @ 30" Row	4
5	301967	110	88" Rear Basket Only -- 1½" Brg. - 3 @ 30" Row	4
6	507081	3¼	1½" Cast Flange Bearing Assembly	16
-	411546	-	Hex Bolt -- 1/2" x 1¾" NC - Gr. 5 - Zinc	32
-	410008	-	Lock Nut -- 1/2" NC - Zinc	32
7	411237	1	Hex Bolt -- 5/8" x 8" NC - Gr. 2 - Zinc	12
-	200412	-	Formed Head Holder	12
-	410009	-	Lock Nut -- 5/8" NC - Gr. 2 - Zinc	12
-	202350	-	Cup Washer for Spring	12
8	471006	1½	Compression Spring	12

HITCH ASSEMBLY

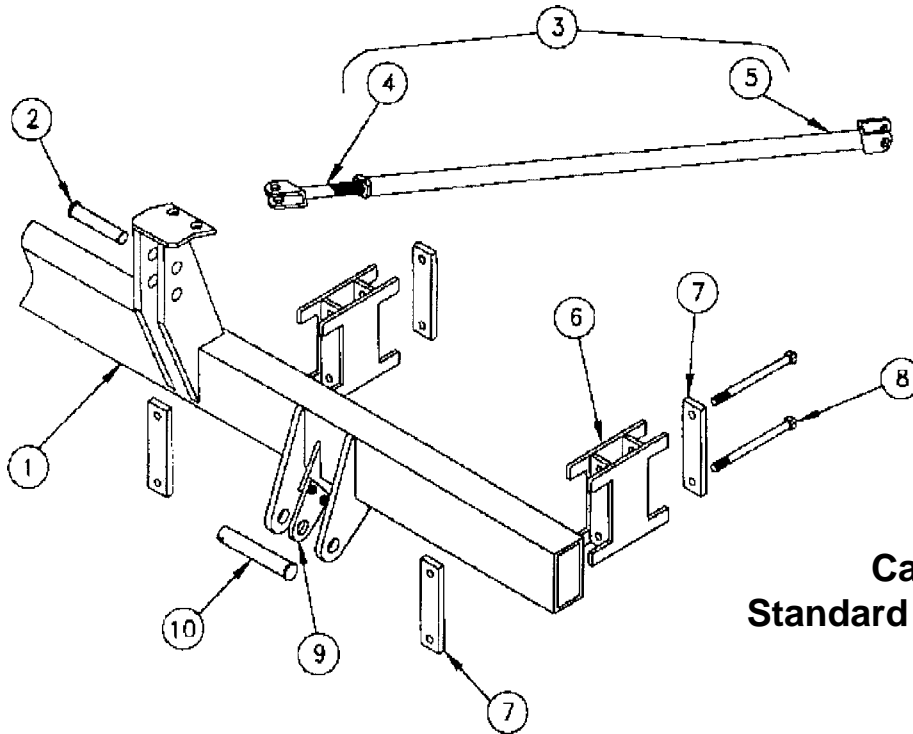

**Cat. III
Standard or Narrow**

<u>ITEM NO.</u>	<u>PART NO.</u>	<u>WT. LBS.</u>	<u>DESCRIPTION</u>	<u>QTY. REQ. FOR 1 HITCH</u>
1	302005	324	Hitch (102" Main Tube)	1
2	416698	2	1 1/4" Top Link Pin - Zinc	1
-	416207	-	Klik Pin -- 7/16" - Zinc	1
3	773666	21 1/2	Adjusting Arm Assembly	2
-	416659	.70	Clevis Pin -- 1" x 2-21/32" - Zinc	4
-	416309	-	Rue Ring Cotter Pin 1" - Zinc	4
4	300381	5 1/4	Turnbuckle Bottom (Rod)	2
5	301602	16 1/4	Turnbuckle Body (65" Pipe)	2
6	302014	25	5" Spacer Block - Top Leveling Stacker	4
7	203960	5	Backing Plate - Top Leveling Stacker	8
-	411598	1/2	Hex Bolt -- 3/4" x 6 1/2" NC - Gr 5 - Zinc	8
-	412012	-	Hex Nut -- 3/4" - 10 - Gr 2 - Zinc	8
-	413512	-	Lock Washer -- 3/4" - Zinc	8
8	411604	1 1/4	Hex Bolt -- 3/4" x 10" NC - Gr 5 - Zinc	8
-	412012	-	Hex Nut -- 3/4" - 10 - Gr 2 - Zinc	8
-	413512	-	Lock Washer -- 3/4" - Zinc	8
9	204117	3	Hitch Center Pull Plate	2
-	411214	1/4	Hex Bolt -- 5/8" x 2" NC - Gr. 2 - Zinc	4
-	412010	-	Hex Nut -- 5/8" - 11 - Gr 2 - Zinc	4
-	413510	-	Lock Washer -- 5/8" - Zinc	4
10	300841	4 1/4	Hitch Pin -- 1-7/16" x 9"	2
-	416207	-	Klik Pin -- 7/16" - Zinc	2

RATCHET ADJ. GAUGE WHEELS



No. 1338
1 Pair Required

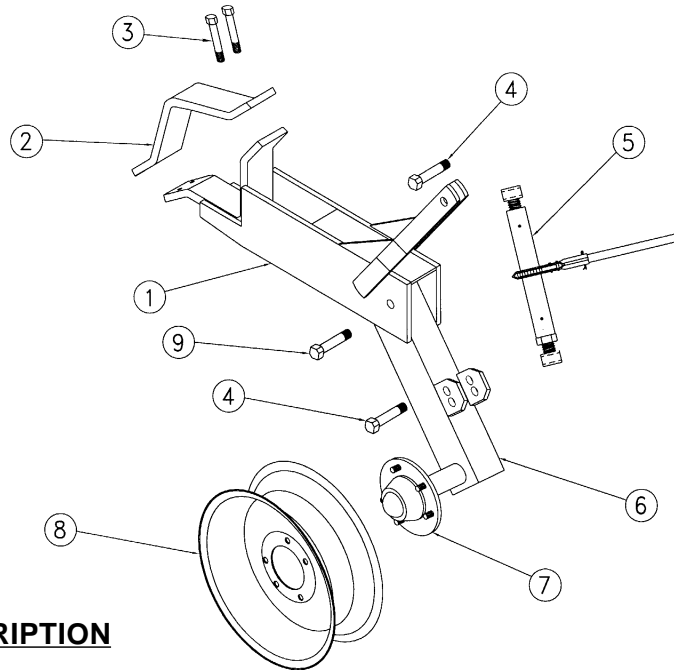

ITEM NO.	PART NO.	WT. LBS.	DESCRIPTION	QTY. REQ. FOR 1 ASSEMBLY
1	302225	60	Holder -- Gauge Wheels	1
2	203770	10	Backing Clamp for 7" Sq. Bar.....	1
3	411591	1/2	Hex Bolt -- 3/4" x 4" NC - Gr 5 - Zinc	4
-	412012	-	Hex Nut -- 3/4" - 10 - Gr 2 - Zinc.....(Not Illustrated)	4
-	413512	-	Lock Washer -- 3/4" - Zinc.....(Not Illustrated) ...	4
4	411591	1/2	Hex Bolt -- 3/4" x 4" NC - Gr 5 - Zinc	2
-	412012	-	Hex Nut -- 3/4" - 10 - Gr 2 - Zinc.....(Not Illustrated)	2
-	413512	-	Lock Washer -- 3/4" - Zinc.....(Not Illustrated) ...	2
5	302025	11 1/2	Ratchet Crank Assembly	1
6	302226	34 3/4	RH Leg w/Hub -- #1338 Gauge Wheel	1
-	302227	34 3/4	LH Leg w/Hub -- #1338 Gauge Wheel.....(Not Illustrated)	1
7	491119	11	5 Hole Hub Complete - Q-719	1
-	491007	9 3/4	Hub w/Cups Only - Q-719.....(Not Illustrated)	1
-	481205	1/4	Cone - Q809 & Q719 - LM67048.....(Not Illustrated) ...	1
-	496010	-	Outer Cup - Q809 & Q719 - LM67010.....(Not Illustrated) ...	1
-	481204	1/4	Cone - Q809 & Q719 - LM48548.....(Not Illustrated) ...	1
-	496011	-	Inner Cup - Q809 & Q719 - LM48510.....(Not Illustrated) ...	1
-	497010	-	Grease Seal - Q719 - CR 15190.....(Not Illustrated) ...	1
-	490006	1/4	Hub Cap - Q809 & Q719.....(Not Illustrated)	1
-	490015	-	1/2" NF Lug Nut.....(Not Illustrated)	5
-	490017	-	Drive-In Hub Bolt - Q719.....(Not Illustrated)	5
-	412164	-	Slotted Nut -- 7/8" - 14 Spindle.....(Not Illustrated) ...	1
-	490034	-	Spindle Washer -- 7/8" - Q875/Q809/Q719.....(Not Illustrated)	1
8	493007	17	15" x 5" x 5 Hole Wheel	1
9	411594	3/4	Hex Bolt -- 3/4" x 5" NC - Gr 5 - Zinc	1
-	412012	-	Hex Nut -- 3/4" - 10 - Gr 2 - Zinc.....(Not Illustrated)	1
-	413512	-	Lock Washer -- 3/4" - Zinc.....(Not Illustrated)	1