

**14 BLADE
LEVEE PLOW
TAPER GANG**

Model No. 0852 -- 14 Blade

0852 - 14 Blade Taper Gang Levee Plow

TURNBUCKLE & SCOPING ARM

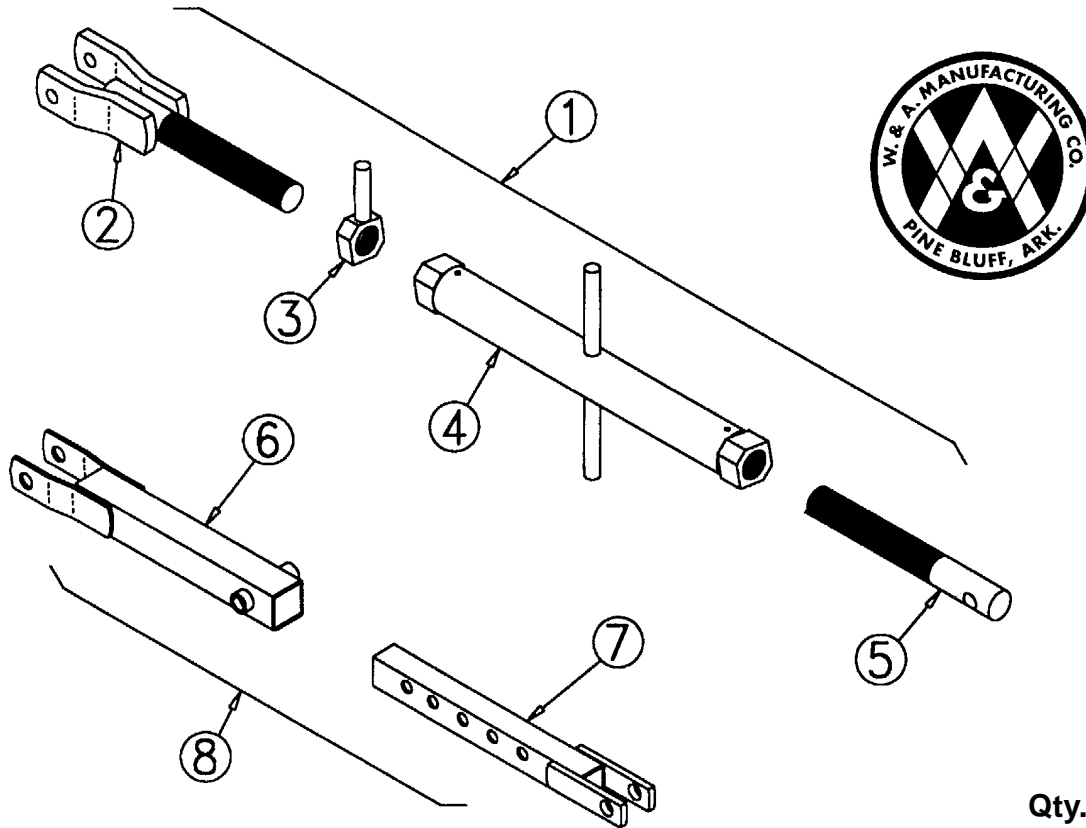

Item No.	Part No.	Wt. Lbs.	Description	Qty. Req'd for 1 Gang
1	708031	25	Turnbuckle Complete (TLP).....(Includes 2, 3, 4 & 5)	1
2	800909	10	Yoke End – RH (Taper Levee Plow)	1
-	411567	¼	Hex Bolt -- 5/8" x 4½" NC - Gr 5 - Zinc	1
-	410009	-	Lock Nut -- 5/8" NC - Gr 2 - Zinc	1
3	800907	1	Jam Nut – 1½" (Taper Levee Plow)	1
4	800905	9	Turnbuckle Body (Taper Levee Plow)	1
-	450004	-	1/4" Drive-In Grease Fitting	2
5	805030	5	Turnbuckle End – LH (Taper Levee Plow)	1
-	411590	¼	Hex Bolt -- 3/4" x 3½" NC - Gr 5 - Zinc	1
-	410012	-	Lock Nut -- 3/4" NC - Gr 2 - Zinc	1
6	800911	5¼	Outer Scoping Arm (Taper Levee Plow)	1
7	800910	4	Inner Scoping Arm (Taper Levee Plow)	1
8	708032	9¾	Scoping Arm Assembly(TLP).....(Includes 6, 7 & Bolts)	1
-	411566	¼	Hex Bolt -- 5/8" x 4" NC - Gr 5 - Zinc	1
-	413510	-	Lock Washer -- 5/8" - Zinc.....	1
-	412010	-	Hex Nut -- 5/8" - 11 - Gr 2 - Zinc.....	1
-	411590	-	Hex Bolt -- 3/4" x 3½" NC - Gr. 5 - Zinc.....	2
-	413512	-	Lock Washer -- 3/4" - Zinc.....	2
-	412012	-	Hex Nut -- 3/4" - 10 - Gr 2 - Zinc.....	2

0852 - 14 Blade Taper Gang Levee Plow

SINGLE TOOL BAR

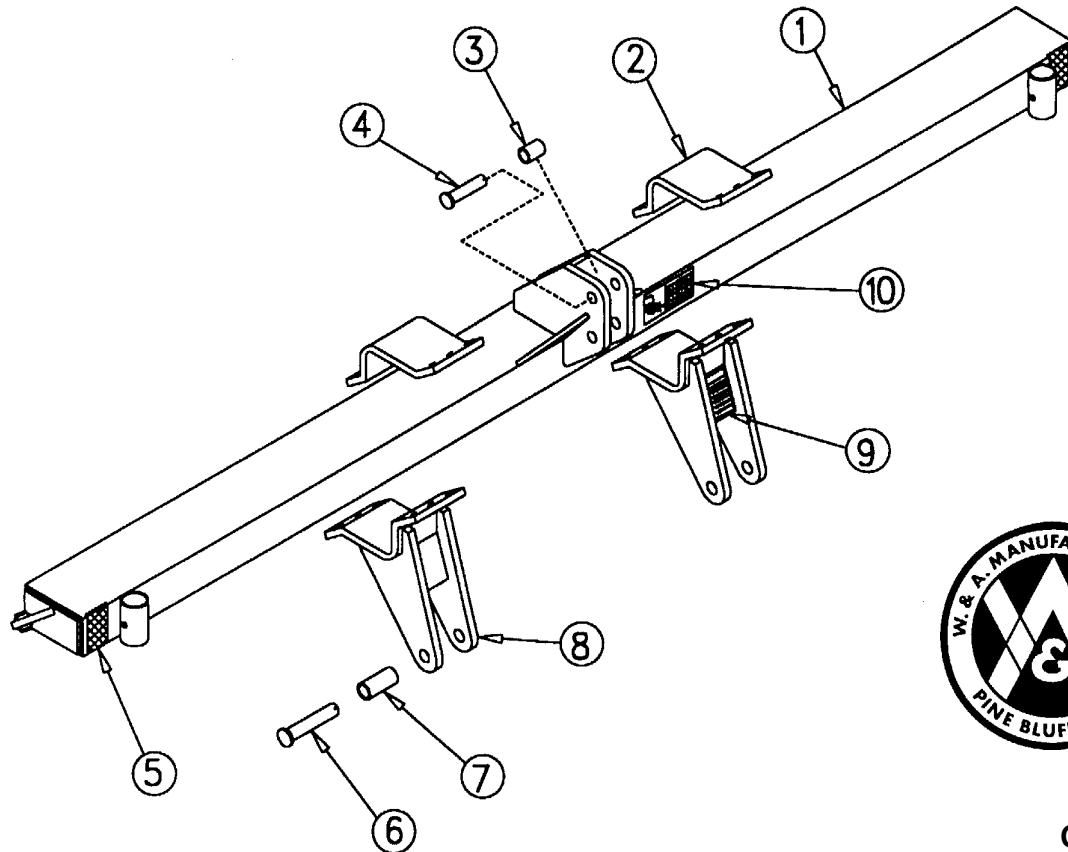

Item No.	Part No.	Wt. Lbs.	Description	Qty. Req'd for 1 Machine
1	800918	358	Tool Bar – Single Plow (Taper Levee Plow)	1
2	805058	16½	Backing Plate (Taper Levee Plow)	2
-	411566	¼	Hex Bolt -- 5/8" x 4" NC - Gr 5 - Zinc	12
-	412010	-	Hex Nut -- 5/8" - 11 - Gr 2 - Zinc	12
-	413510	-	Lock Washer -- 5/8" - Zinc	12
3	201799	-	Cat. III Bushing -- 1¼" OD x 2-1/8" Long	1
4	416666	1	Clevis Pin -- 1" x 4½" - Zinc	1
-	416309	-	Rue Ring Cotter Pin 1" - Zinc	1
5	461200	-	Decal -- Amber Reflector - 4½" x 2"	2
-	461201	-	Decal -- Red Reflector - 4½" x 2".....(On back of Bar)	2
6	416685	2	Clevis Pin -- 1-1/8" x 5½" - Zinc	2
-	416309	-	Rue Ring Cotter Pin -- 1" - Zinc	2
7	802301	½	Hitch Bushing x 3-3/8" (Taper Levee Plow)	2
8	800920	48	Pull Piece (Taper Levee Plow)	2
9	461123	-	Warning Decal -- Operator's Manual	1
10	461138	-	Danger Decal -- Crushing Hazard	1
N/I	800185	-	Parking Stand - Levee Plow	2
-	416228	-	1/2" Safety Lock Pin x 5½" OAL - Zinc	2

0852 - 14 Blade Taper Gang Levee Plow

GANG FRAME ASSEMBLY

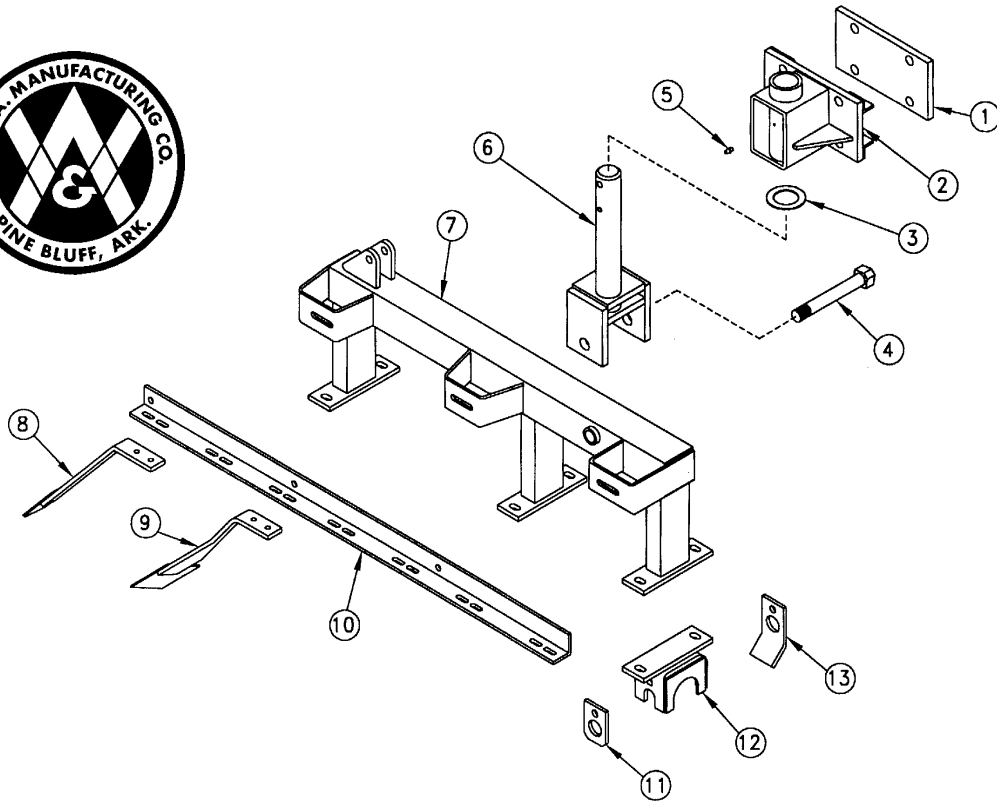

Item No.	Part No.	Wt. Lbs.	Description	Qty. Req'd for 1 Gang
1	805118	18	Backing Plate (Taper Levee Plow)	1
-	411655	2¼	Hex Bolt -- 1" x 10" NC - Gr 5 - Zinc	4
-	412016	-	Hex Nut -- 1" - 8 - Gr 2 - Zinc	4
-	413516	-	Lock Washer -- 1" - Zinc	4
2	800934	42½	Gang Support Top (Taper Levee Plow)	1
3	413132	-	Machine Washer -- 3-7/8" OD x 2½" ID x 10 Ga	1
4	411673	3	Hex Bolt -- 1¼" x 9" NC - Gr 5 - Zinc	1
-	412420	-	Jam Nut -- 1¼" - 7 - Gr 2 - Zinc	2
-	413020	-	Flat Washer -- 1¼" - Zinc	1
5	450004	-	1/4" Drive-In Grease Fitting	1
6	800932	45	Gang Support Pivot (TLP) - 2½" Dia. Rod	1
-	416133	-	Roll Pin -- 1/2" x 3½" - Zinc	1
7	800930	105	Gang Frame -- LH (Taper Levee Plow).....(Shown)	1
-	800929	105	Gang Frame -- RH (Taper Levee Plow)	1
8	800937	5½	Outside Scraper – LH (Taper Levee Plow)	3
-	800936	5½	Outside Scraper – RH (Taper Levee Plow)	3
-	411785	-	Carriage Bolt -- 1/2" x 1½" NC - Gr 5 - Zinc	6
-	413508	-	Lock Washer -- 1/2" - Zinc	6
-	412008	-	Hex Nut -- 1/2" - 13 - Gr 2 - Zinc	6

0852 - 14 Blade Taper Gang Levee Plow

GANG FRAME ASSEMBLY

(Continued)

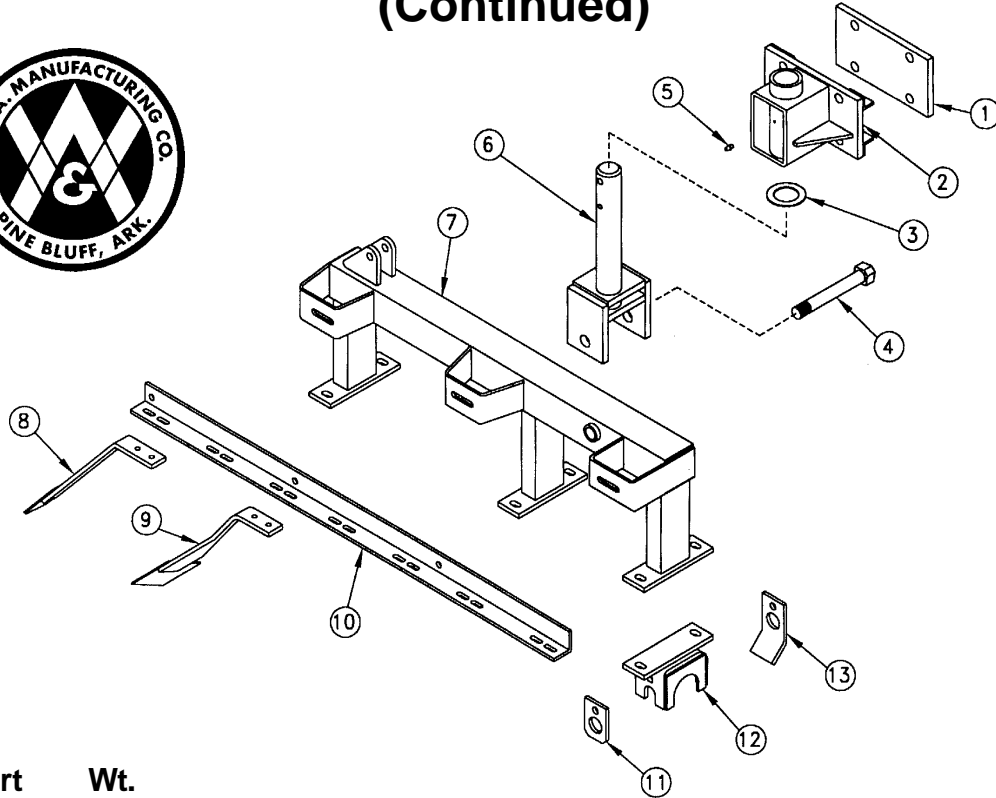

Item No.	Part No.	Wt. Lbs.	Description	Qty. Req'd for 1 Gang
9	800939	5½	Inside Scraper – LH (TLP).....(w/Twist in Leg)	4
-	800938	5½	Inside Scraper – RH (TLP).....(w/Twist in Leg)	4
-	411785	-	Carriage Bolt -- 1/2" x 1½" NC - Gr 5 - Zinc	8
-	413508	-	Lock Washer -- 1/2" - Zinc	8
-	412008	-	Hex Nut -- 1/2" - 13 - Gr 2 - Zinc.....	8
10	805106	27	Scraper Bar – LH (Taper Levee Plow)	1
-	805105	27	Scraper Bar – RH (Taper Levee Plow)	1
-	411790	-	Carriage Bolt -- 5/8" x 2" NC - Gr 5 - Zinc	3
-	413510	-	Lock Washer -- 5/8" - Zinc.....	3
-	412010	-	Hex Nut -- 5/8" - 11 - Gr 2 - Zinc.....	3
11	805094	1	Rear Trunion Clamp (Taper Levee Plow)	3
-	411790	-	Carriage Bolt -- 5/8" x 2" NC - Gr 5 - Zinc.....	3
-	412010	-	Hex Nut -- 5/8" - 11 - Gr 2 - Zinc.....	3
-	413510	-	Lock Washer -- 5/8" - Zinc.....	3
12	800926	12½	Trunion Housing (Taper Levee Plow).....	3
-	411790	-	Carriage Bolt -- 5/8" x 2" NC - Gr 5 - Zinc	6
-	412010	-	Hex Nut -- 5/8" - 11 - Gr 2 - Zinc.....	6
-	413510	-	Lock Washer -- 5/8" - Zinc.....	6
13	805093	2½	Front Trunion Clamp (Taper Levee Plow)	3
-	411790	-	Carriage Bolt -- 5/8" x 2" NC - Gr 5 - Zinc	3
-	412010	-	Hex Nut -- 5/8" - 11 - Gr 2 - Zinc.....	3
-	413510	-	Lock Washer -- 5/8" - Zinc.....	3

0852 - 14 Blade Taper Gang Levee Plow

TAPERED GANG PARTS

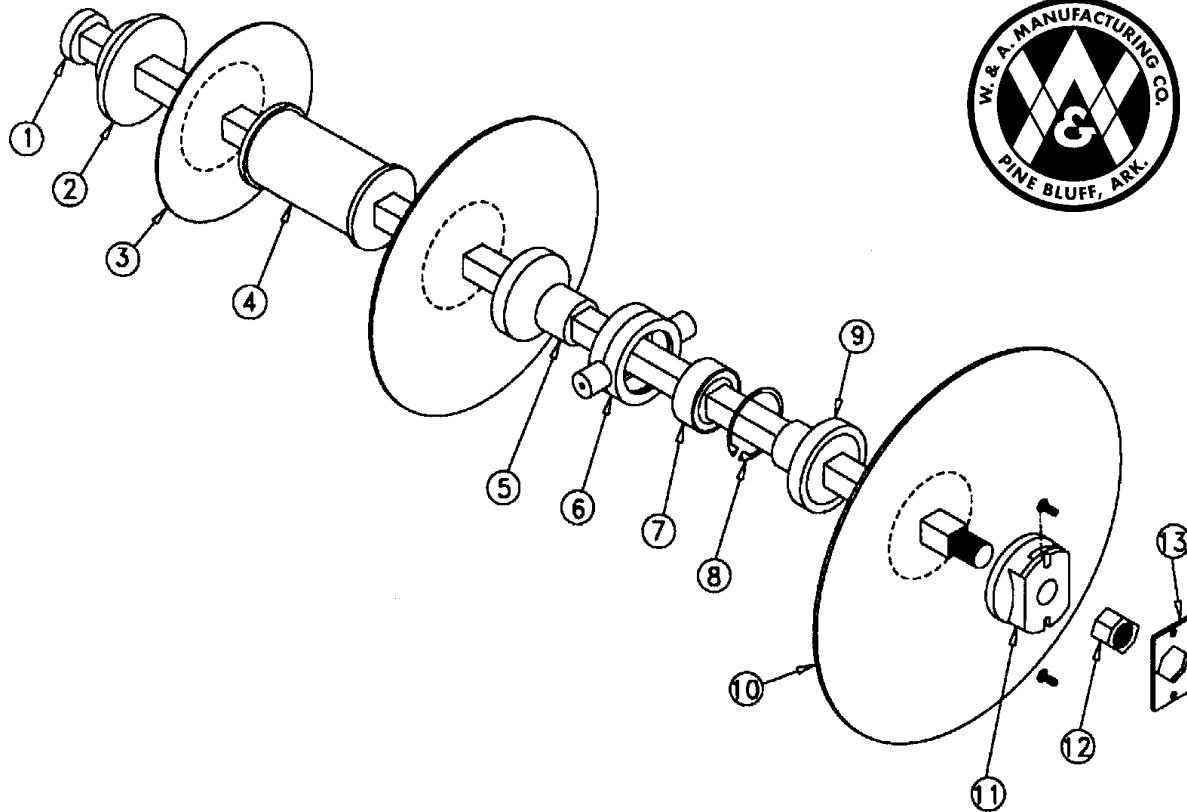

Item No.	Part No.	Wt. Lbs.	Description	Qty. Req'd for 1 Gang
1	478117	37	1½" Sq. x 57¾" NF Axle w/Nut (Taper Levee Plow).....	1
2	802384	4¾	Bumper Washer - Levee Plow.....	1
3	473712	14	12" x 6.0MM RFC Plain Blade - 1½" Sq Ctr Hole	1
-	473714	6½	14" x 4.0MM RFC Plain Blade - 1½" Sq Ctr Hole	1
-	473716	9	16" x 4.0MM RFC Plain Blade - 1½" Sq Ctr Hole	1
-	473718	11½	18" x 4.0MM RFC Plain Blade - 1½" Sq Ctr Hole	1
-	473720	16	20" x 4.5MM RFC Plain Blade - 1½" Sq Ctr Hole	1
-	473722	19	22" x 4.5MM RFC Plain Blade - 1½" Sq Ctr Hole	1
4	800193	10½	Spacer Spool - 9" - Levee Plow	3
5	802005	7	Large End Bell - Levee Plow	3
6	802006	7	Bearing Housing - Levee Plow	3
-	450102	-	1/8" NPT Grease Fitting	3
-	505001	9½	Bearing & Housing Assembly - Levee Plow	3

TAPERED GANG PARTS
(Continued)

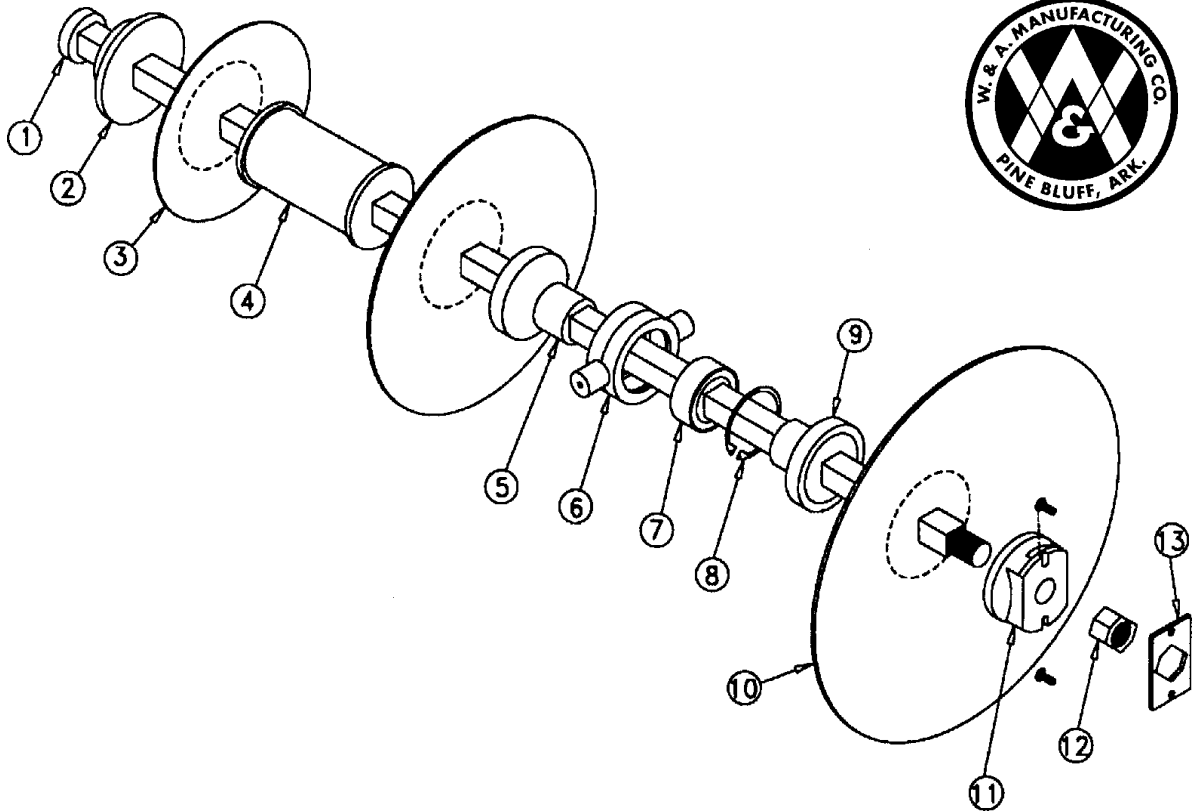

<u>Item No.</u>	<u>Part No.</u>	<u>Wt. Lbs.</u>	<u>Description</u>	<u>Qty. Req'd for 1 Gang</u>
7	481213	2½	Bearing - 1½" Sq. Bore - GW211PP3	3
8	483393	-	Retaining Ring - LP & 1½" Axle Bedder	3
9	802004	6	Small End Bell - Levee Plow	3
10	473230	41½	24" x 5/16" RFC PI Blade - 1½" Sq Ctr Hole	1
11	802256	6½	End Gang Washer - Levee Plow	1
12	412824	1	Hex Nut -- 1½" - 12 - Gr 5 - Zinc.....	1
13	802340	1	Lock Plate - Levee Plow	1
-	411711	-	Carriage Bolt -- 3/8" x 1" NC - Gr 2 - Zinc	2
-	413506	-	Lock Washer -- 3/8" - Zinc.....	2
-	412006	-	Hex Nut -- 3/8" - 16 - Gr 2 - Zinc.....	2