

# W & A

## DOUBLE TAPER BLADE LEVEE PLOW

### NO. 856

<u>Part Number</u>	<u>Description</u>	<u>Quantity</u>
708017	Double Main Frame Assembly.....	1
708024	Taper Blade Gang Assembly - RH .....	2
708025	Taper Blade Gang Assembly - LH .....	2

## OPERATOR'S MANUAL

Congratulations on your purchase of a new W & A Double Taper Blade Levee Plow. Be sure to read all the instructions in this manual before placing the machine in use. Safety precautions along with adjustments should be learned and also taught to anyone who operates the machine. Remember, an implement which is properly maintained, adjusted and safely operated saves time, labor and money.

After operating season, thoroughly clean your levee plow and inspect it. Preventive maintenance pays dividends. Your dealer has original equipment parts which assure proper fit and best performance.

Thank you for purchasing this W & A product.

\*\*\*\*\*

For your convenience, please fill in the following:

Model: Double Taper Blade Levee Plow    Item No. 856    Serial No. \_\_\_\_\_

Dealer Name: \_\_\_\_\_    Date Purchased \_\_\_\_\_

# SAFETY

SI NO LEE INGLES, PIDA AYUDA A AIGUIEN QUE SI LO LEA PARA QUE LE TRADUZCA LAS MEDIDAS DE SEGURIDAD.



THIS SYMBOL MEANS

**-ATTENTION!**

**-BECOME ALERT!**

**-YOUR SAFETY IS INVOLVED!**

## SIGNAL WORDS:

The signal words DANGER, WARNING and CAUTION are used with the safety messages in this manual and with each safety sign. They are defined as follows:

**DANGER:** Indicates an imminently hazardous situation that, if not avoided, will result in death or serious injury. This signal word is to be limited to the most extreme situations typically for machine components which, for functional purposes, cannot be guarded. The color for DANGER is RED.

**WARNING:** Indicates a potentially hazardous situation that, if not avoided, could result in death or serious injury, and includes hazards that are exposed when guards are removed. It may also be used to alert against unsafe practices. The color for WARNING is ORANGE.

**CAUTION:** Indicates a potentially hazardous situation that, if not avoided, may result in minor or moderate injury. It may also be used to alert against unsafe practices. The color for CAUTION is YELLOW.

- Safety of the operator and bystanders is one of the main concerns in designing and developing our products. However, every year accidents occur which could have been avoided by a few seconds of thought and a more careful approach to handling equipment. You, the operator, can avoid many accidents by observing the following precautions in this manual. To avoid personal injury or death, study the following precautions and insist those working with you, or for you, follow them.



If you have any questions not answered in this manual, require additional copies or the manual is damaged, please contact your dealer or W & A Manufacturing Company, P. O. Box 5238, Pine Bluff, Arkansas 71611. (Telephone) 870-534-7420, (FAX) 870-534-1318. Manuals can also be found at [www.wamfgco.com](http://www.wamfgco.com)



This is the safety alert symbol. When you see this symbol on your machine or in this manual, be alert to the potential for personal injury or death. Follow the Safety Requirements!



## GENERAL SAFETY REQUIREMENTS



- Before operating your W & A Levee Plow, thoroughly read and understand your operator's manual. If you do not understand any portion of the operator's manual, contact your dealer or W & A Manufacturing Company immediately.
- Never operate the machine under the influence of alcohol or drugs, or while you are otherwise impaired.
- This equipment is dangerous to children and persons unfamiliar with its operation. The operator should be a responsible adult familiar with farm machinery and trained in this equipment's operations. **Do not allow persons to operate or assemble this unit until they have read this manual and have developed a thorough understanding of the safety precautions and of how it works.**
- Clear the area of people, especially children, before starting unit.
- Do not allow anyone to ride on any part of the equipment for any reason.
- If safety signs are missing, unreadable, or damaged, they should be replaced. See list of safety signs. Keep safety signs clean and legible. Do not paint over safety signs.
- Furnish this manual to the new owner if the machine is sold.
- Inspect machine daily for worn parts, hydraulic leaks, frayed hoses, and make necessary repairs. Tighten all bolts and make sure all fasteners are in place.
- Unauthorized modifications to the machine may impair the function and/or safety and affect machine life. Make NO unauthorized modifications.
- Never stand between implement and tractor when hitching. Extreme care should be used to prevent injury to the hands or fingers. Place all controls in neutral, stop tractor engine, set park brake, and wait for all moving parts to stop before service, adjusting, repairing or unplugging.
- Lower machine and lower parking stands before servicing, adjusting, leaving, or storing.
- Raised equipment can fall unexpectedly and crush persons underneath. Never allow anyone to enter the area underneath raised equipment during operation.
- Do not read, eat, drink, talk or text or use a mobile phone while using this equipment.
- Review the safety instructions with all users annually.



## TRANSPORTING



- Comply with all federal, state, and local laws for implement transport on public roads.
- Watch for obstructions overhead and to side while transporting.
- Travel speed should be such that you maintain complete control and machine stability at all times.
- Make sure that the brake pedal latch is engaged. You must lock brake pedals together for road travel.
- Slow down and signal before turning. Pull over to allow faster traffic to pass.
- Never transport machine unless hydraulic systems are completely charged with hydraulic oil and transport safety locks are engaged.
- Before transporting engage Lock Pin to keep plow from swinging: —————→
- When transporting on a road or highway, use adequate warning symbols, reflectors, and SMV (slow moving vehicle) emblem and appropriate lighting to meet local regulations. Avoid transporting at night or low light conditions.



-- PIN DOWN for TRAVEL --



## OPERATIONS



- Never start or operate machine unless sitting on tractor seat.
- Always make sure hydraulic system is fully charged with oil before use. Failure to bleed the system of all air can cause folded wings or entire machine to drop suddenly.
- Make sure front of tractor is properly weighted for safe steering control and operation.
- Clear the area of people, especially children, before starting the unit.
- Do not allow anyone to stand between tractor and implement when hitching.
- Do not operate hydraulic wings and/or arms until you are sure all bystanders are clear of area.
- Coulter, disk and marker blades are sharp. Use extreme care when adjusting or servicing. Keep hands and feet from beneath blades.



# SERVICE/MAINTENANCE



- Before working on this machine stop the tractor, set the brakes, disengage the PTO and power drives, shut off the engine and remove the ignition key.
- Securely block machine when working on or under it.
- Always use the proper tools or equipment for the job.
- Properly tighten all hardware.

## SAFETY SIGNS

- Keep safety signs clean and legible at all times.
- Replace safety signs that are missing or have become illegible.
- Replaced parts that displayed a safety sign must also display the current sign.
- Safety signs are available from your dealer or W & A Manufacturing Company.

A. Amber Rectangular Reflector. Sign Number 461200

B. Red Rectangular Reflector. Sign Number 461201

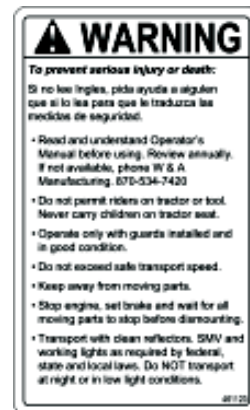
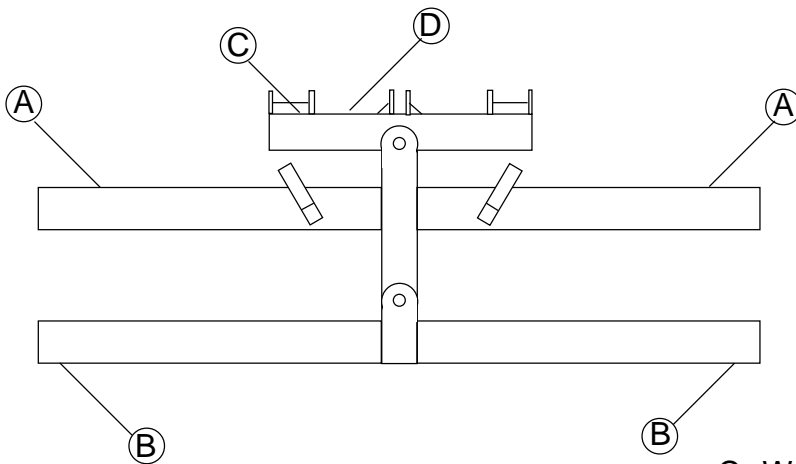

C. WARNING - Read Operator's Manual. Sign Number 461123.

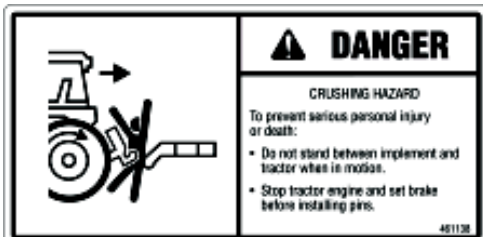

D. DANGER - Crushing Hazard. Sign Number 461138

# ADJUSTMENTS & OPERATION



LOWER UNIT BEFORE SERVICING, ADJUSTING, OR LEAVING MACHINE.

1. Make all adjustments on a flat level surface.
2. Set the side to side angle so that the discs are setting flat on the ground by adjusting the turnbuckles. This will assure that the outside of the levee will not have a ditch. If you have a ditch, raise the outside of the gang to eliminate the ditch.
3. The height of the levee is determined by the front to rear angle of the gangs. Setting the gangs at a sharper angle back will make a higher levee. Adjusting the scoping arm assemblies at the ends of the tool bar adjusts this angle.
4. The width of the levee is determined by the spacing between the gang assemblies.



-- PIN DOWN for TRAVEL --



-- PIN UP for PLOWING --

5. The lock pin should be used for transporting the levee plow. DO NOT HAVE THE LOCK PIN LOCKED DURING FIELD USE. To unlock for field use: Rotate handle up and over 180 degrees. This will assure that the handle will not flip into lock position during field use and that the pin is unlocked. (Travel / Plow Decal No. 461100 - replace if torn or missing. Two required.)



INSTALL PROPER BALLAST ON FRONT OF TRACTOR. INSURE SAFE AND PROPER STEERING AT ALL TIMES.



EXTREME CARE SHOULD BE USED WHEN HITCHING BAR TO TRACTOR TO PREVENT INJURY TO HANDS OR FINGERS. DO NOT STAND BETWEEN THE TOOL BAR AND TRACTOR WHEN IT IS IN MOTION. STOP TRACTOR ENGINE AND SET BRAKE BEFORE INSTALLING PINS.

# LUBRICATION & MAINTENANCE



LOWER UNIT BEFORE SERVICING, ADJUSTING OR LEAVING MACHINE.

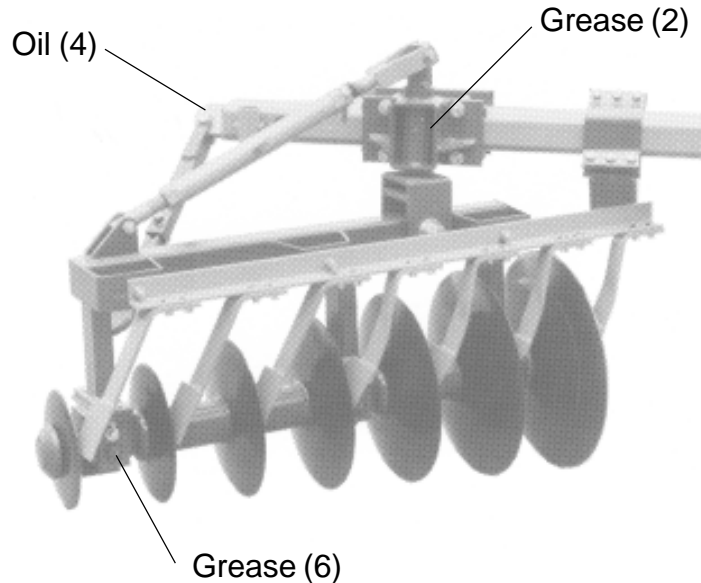

## DAILY OR AFTER 10 HOURS OF OPERATION:

1. Grease all bearing assemblies.

## WEEKLY OR AFTER 50 HOURS OF OPERATION:

1. Retighten all bolts and check that all fasteners and keepers are in place and secure.
2. Grease hitch pivot and rear bar pivot.

## PERIODICALLY:

Thoroughly clean and inspect your levee plow. Tighten all bolts as needed and check that all fasteners and keepers are in place and secure.

Check hitch pins for wear and replace as required.

Grease all bearing assemblies and pivots before storing implement for an extended period of time.

Review safety instructions with all operators annually.

# ASSEMBLY



EXTREME CARE SHOULD BE USED DURING ASSEMBLY TO PREVENT INJURY TO HANDS, FINGERS AND FEET.

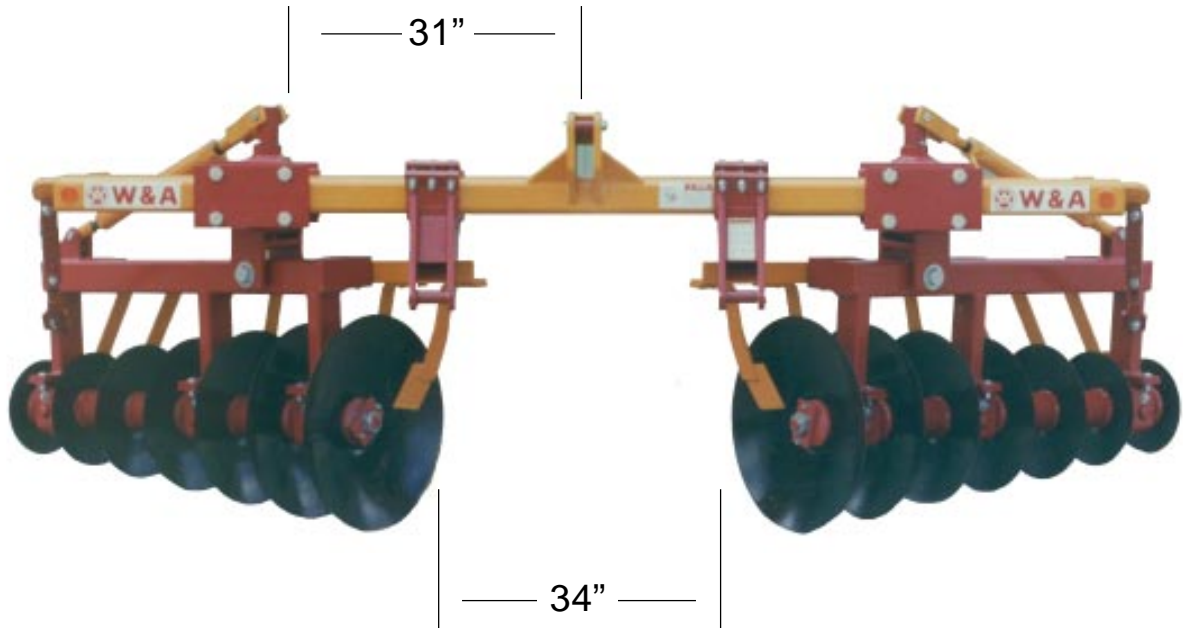

1. Mount the tool bar and three point hitch assembly on the tractor three point hitch. The hitch pull piece assemblies are adjustable for either category II of category III. They are set on category III at the factory.
2. Starting at the center, place a mark on the tool bar at 31" on each side of center. Place the inside of the attaching bracket on the 31" mark and attach the right and left gang assemblies to the tool bar using the bolts provided. This should space the inside 24" blades approximately 34" apart.
3. Attach the scoping arm assemblies to the ends of the tool bar using the bolts provided.



INSTALL PROPER BALLAST ON FRONT OF TRACTOR TO INSURE SAFE AND PROPER STEERING AT ALL TIMES.



EXTREME CARE SHOULD BE USED WHEN HITCHING BAR TO TRACTOR TO PREVENT INJURY TO HANDS OR FINGERS. DO NOT STAND BETWEEN THE TOOL BAR AND TRACTOR WHEN IT IS IN MOTION. STOP TRACTOR ENGINE AND SET BRAKE BEFORE INSTALLING PINS.



# WARRANTY

W & A Manufacturing Company warrants all products manufactured and sold by it to be free of defects in material and workmanship and to perform as represented, subject to the following conditions

- (A) Warranty applies only if installed and operated according to instructions.
- (B) Written authorization must be obtained prior to return of material for inspection. Material is to be returned prepaid.
- (C) Warranty does not apply to labor for parts replacement, nor does it apply to damage by accident, abuse, misuse or failure caused by not operating according to instructions.
- (D) Warranty is void if changes are made in the product in the field by other than a W & A representative or by instructions from the factory.

**W & A Manufacturing Company reserves the right at any time to make changes in the design, materials and/or specifications of any of its products without thereby becoming liable to make similar changes in equipment previously manufactured.**

Written authorization must be obtained prior to the return of any equipment purchased from W & A Manufacturing Company. No penalties will be charged if equipment had been placed on display by a W & A representative or if reasons for return are errors or faults of W & A Manufacturing Company. If return is for the benefit of the customer and the equipment is returned by prepaid freight in a new, unused and resalable condition, credit (based on original purchase price) will be issued less a 10% fee for restocking and other handling expenses.



*Quality Products from*

**W & A MANUFACTURING COMPANY**

P.O. Box 5238, Pine Bluff, Arkansas 71611

Phone: (870) 534-7420

Fax: (800) 336-1318

Website: [www.wamfgco.com](http://www.wamfgco.com)