

LEVEE PLOW DOUBLE TAPER GANG

Model No. 0856 -- 28 Blade

0856 - 28 Blade Double Taper Levee Plow

MAIN FRAME ASSEMBLY

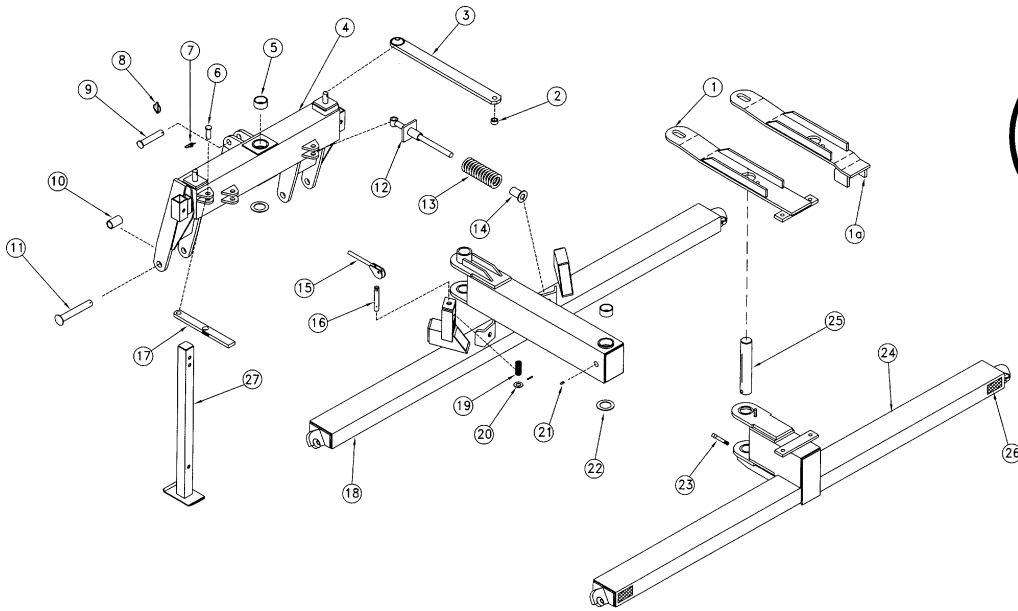

<u>Item No.</u>	<u>Part No.</u>	<u>Wt. Lbs.</u>	<u>Description</u>	<u>Qty. Req'd for 1 Machine</u>
1	800906	47½	Rear Turning Arm.....(2014 & Later)	1
-	411586	¼	Hex Bolt -- 3/4" x 2½" NC - Gr 5 - Zinc	2
-	410009	-	Lock Nut -- 5/8" - Gr 2 - Zinc	1
-	412012	-	Hex Nut -- 3/4" NC - 10 - Gr 2 - Zinc	2
-	413010	-	Flat Washer -- 5/8" - Zinc	1
-	413512	-	Lock Washer -- 3/4" - Zinc.....	2
1a	800904	50	Rear Turning Arm - Parts Only (TLP).....(2013 & Earlier)	-
2	805087	-	Bushing – Stabilizer (Taper Levee Plow)	1
3	800912	20¼	Stabilizer Bar (Taper Levee Plow)	2
-	411642	1	Hex Bolt -- 1" x 3½" NC - Gr 5 - Zinc	1
-	410016	-	Lock Nut -- 1" NC - Top Lock - Zinc	1
-	416207	-	Klik Pin -- 7/16" - Zinc	2
4	800902	315	Three Point Swivel Hitch (Taper Levee Plow).....	1
-	805085	19	Pivot Pin -- 2½" x 14-1/8" w/Grove (TLP).....(See Key 25)	1
-	461123	-	Warning Decal -- Operator's Manual	1
-	461138	-	Danger Decal -- Crushing Hazard.....	1
5	401134	-	Hard Bushing -- 2½" Double Levee Plow	4
6	416659	½	Clevis Pin -- 1" x 2-21/32" - Zinc.....(Use with #17)	1
7	416309	-	Rue Ring Cotter Pin -- 1" - Zinc.....(Use with #17)	1

0856 - 28 Blade Double Taper Levee Plow

MAIN FRAME ASSEMBLY (Continued)

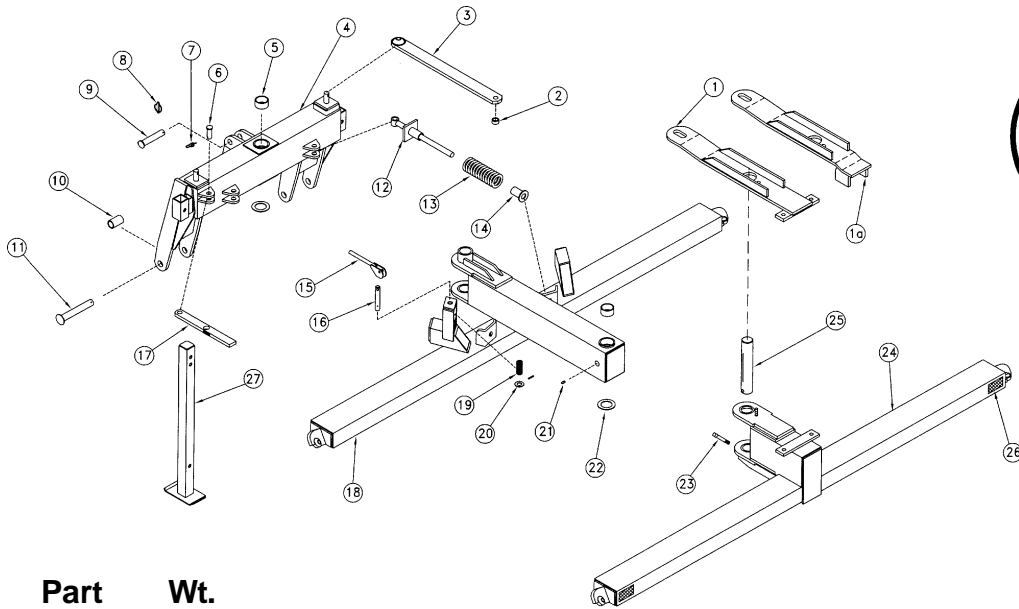

<u>Item No.</u>	<u>Part No.</u>	<u>Wt. Lbs.</u>	<u>Description</u>	<u>Qty. Req'd for 1 Machine</u>
8	416207	-	Klik Pin -- 7/16" - Zinc.....(Use with #9)	1
9	416698	2	1 1/4" Top Link Pin - Zinc	1
10	805086	-	Spacer (Taper Levee Plow)	2
11	300841	4	Hitch Pin -- 1-7/16" x 9"	2
-	416207	-	Klik Pin -- 7/16" - Zinc	2
12	800942	7	Spring Rod (Taper Levee Plow).....(Hitch to Front Bar)	2
-	416662	3/4	Clevis Pin -- 1" x 3 1/2" - Zinc	2
-	416309	-	Rue Ring Cotter Pin -- 1" - Zinc	2
13	471095	7 1/2	Compression Spring -- 5/8" x 10 1/4"	2
14	800943	-	Locator for Spring (Taper Levee Plow)	2
15	800913	2	Transport Lock Handle (Taper Levee Plow)	1
-	411547	-	Hex Bolt -- 1/2" x 2" NC - Gr 5 - Zinc	1
-	410008	-	Lock Nut -- 1/2" NC - Zinc	1
-	413016	-	Flat Washer -- 1" - Zinc	1
-	461100	-	Decal -- Travel / Plow	2
16	805084	1 1/4	Transport Lock Pin -- 1" (Taper Levee Plow)	1
-	411184	-	Hex Bolt -- 1/2" x 2" - Gr 5 - Zinc	1
-	410008	-	Lock Nut -- 1/2" - Zinc	1
17	800914	7	Transport Bar (Taper Levee Plow)	1

0856 - 28 Blade Double Taper Levee Plow

MAIN FRAME ASSEMBLY

(Continued)

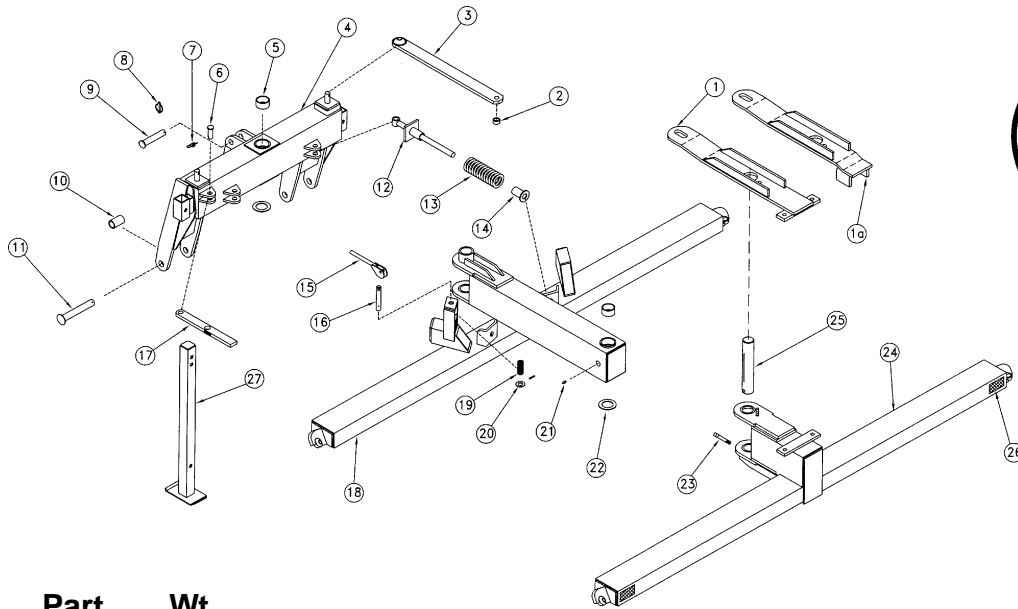

<u>Item No.</u>	<u>Part No.</u>	<u>Wt. Lbs.</u>	<u>Description</u>	<u>Qty. Req'd for 1 Machine</u>
18	800924	570	Front Tool Bar - Levee Plow	1
19	471085	¼	Compression Spring -- 3/16" x 1-1/16" x 3 1/2"	1
20	413115	-	Machine Washer -- 1 1/2" OD x 1" ID x 14 Ga	1
-	416003	-	Cotter Pin -- 5/32" x 1 3/4"	1
21	450004	-	1/4" Drive-in Grease Fitting	1
22	413132	-	Machine Washer -- 3-7/8" OD x 2 1/2" ID x 10 Ga	2
23	411566	¼	Hex Bolt -- 5/8" x 4" NC - Gr. 5 - Zinc	2
-	413510	-	Lock Washer -- 5/8" - Zinc	2
-	412010	-	Hex Nut -- 5/8" - 11 - Gr 2 - Zinc	2
24	800925	445	Rear Tool Bar - Levee Plow	1
25	805085	19	Pivot Pin 2 1/2" x 14-1/8" w/Groove (Taper Levee Plow)	2
26	461201	-	Decal -- Red Reflector - 4 1/2" x 2"	2
-	461200	-	Decal -- Amber Reflector - 4 1/2" x 2" (front of Front Bar)	2
27	800903	12 1/2	Parking Stand (Double Levee Plow)	2
N/I	416230	¾	3/4" Safety Lock Pin x 5 1/2" OAL - Zinc	2

0856 - 28 Blade Double Taper Levee Plow

TURNBUCKLE & SCOPING ARM

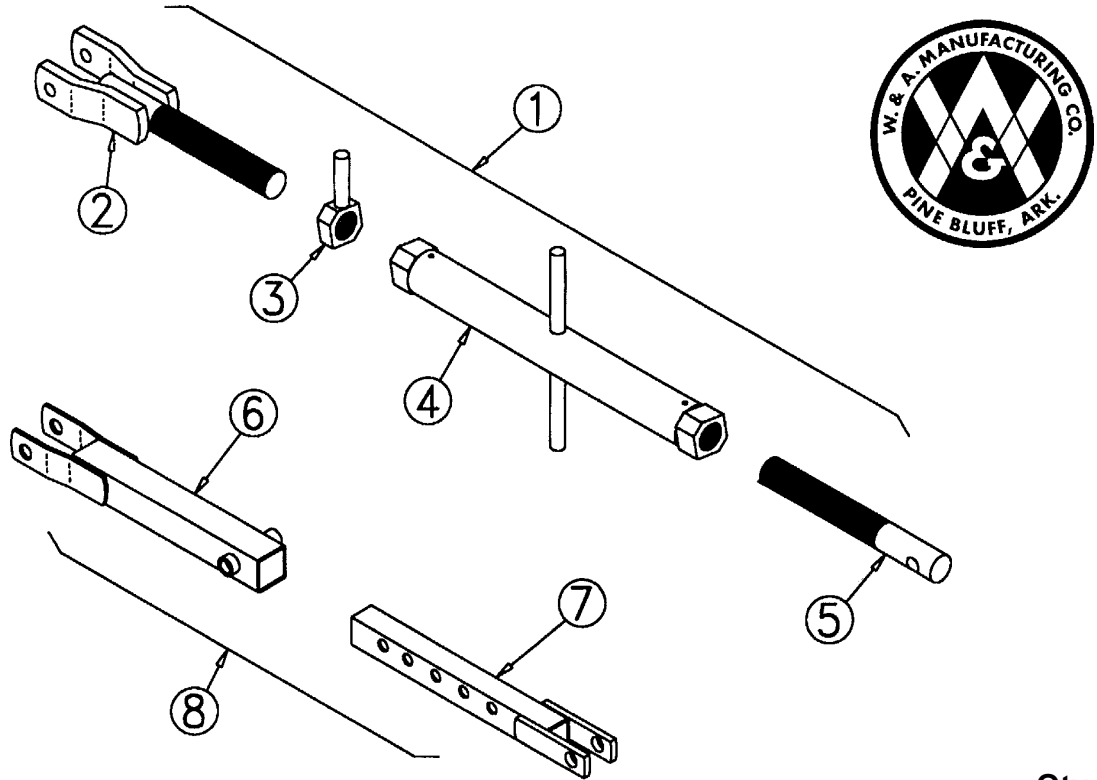

Item No.	Part No.	Wt. Lbs.	Description	Qty. Req'd for 1 Gang
1	708031	25	Turnbuckle Complete - TLP (Includes 2, 3, 4 & 5)	1
2	800909	10	Yoke End – RH (Taper Levee Plow)	1
-	411567	¼	Hex Bolt -- 5/8" x 4½" NC - Gr 5 - Zinc	1
-	410009	-	Lock Nut -- 5/8" NC - Zinc	1
3	800907	1	Jam Nut – 1½" (Taper Levee Plow)	1
4	800905	9	Turnbuckle Body (Taper Levee Plow)	1
-	450004	-	1/4" Drive-In Grease Fitting	2
5	805030	5	Turnbuckle End – LH (Taper Levee Plow)	1
-	411590	¼	Hex Bolt -- 3/4" x 3½" NC - Gr 5 - Zinc	1
-	410012	-	Lock Nut -- 3/4" NC - Zinc	1
6	800911	5¼	Outer Scoping Arm (Taper Levee Plow)	1
7	800910	4	Inner Scoping Arm (Taper Levee Plow)	1
8	708032	9¾	Scoping Arm Assembly - TLP (Includes 6, 7 & Bolts)	1
-	411566	¼	Hex Bolt -- 5/8" x 4" NC - Gr 5 - Zinc	1
-	413510	-	Lock Washer -- 5/8" - Zinc	1
-	412010	-	Hex Nut -- 5/8" - 11 - Gr 2 - Zinc	1
-	411590	-	Hex Bolt -- 3/4" x 3½" NC - Gr. 5 - Zinc	2
-	413512	-	Lock Washer -- 3/4" - Zinc	2
-	412012	-	Hex Nut -- 3/4" - 10 - Gr 2 - Zinc	2

0856 - 28 Blade Double Taper Levee Plow

GANG FRAME ASSEMBLY

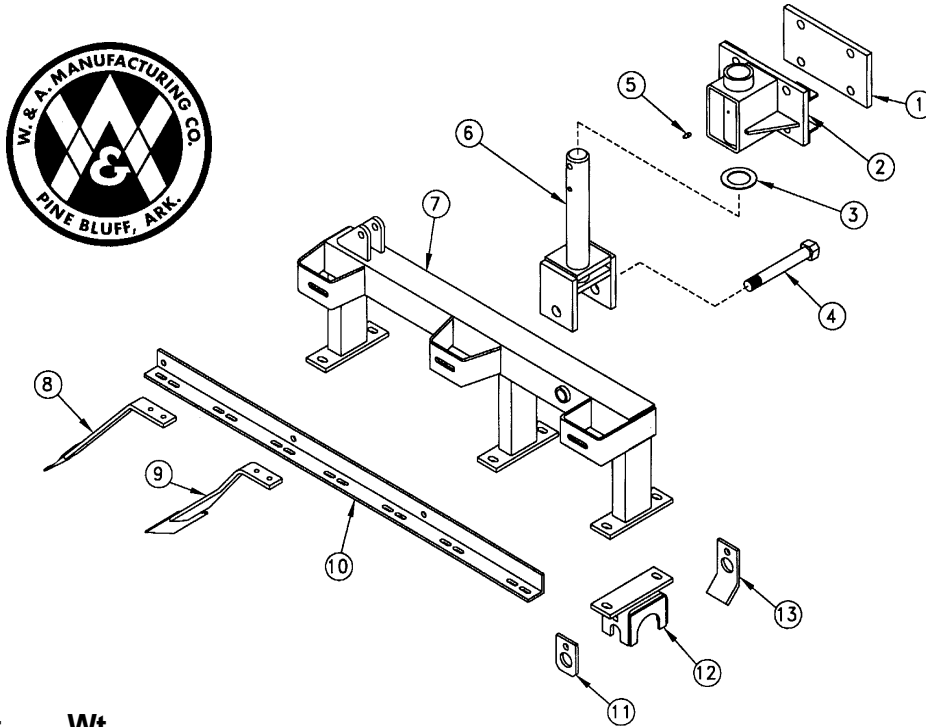

Item No.	Part No.	Wt. Lbs.	Description	Qty. Req'd for 1 Gang
1	805118	18	Backing Plate - Taper Levee Plow	1
-	411655	2¼	Hex Bolt -- 1" x 10" NC - Gr 5 - Zinc	4
-	412016	-	Hex Nut -- 1" - 8 - Gr 2 - Zinc	4
-	413516	-	Lock Washer -- 1" - Zinc	4
2	800934	42½	Gang Support Top - Taper Levee Plow	1
3	413132	-	Machine Washer -- 3-7/8" OD x 2½" ID x 10 Ga	1
4	411673	3	Hex Bolt -- 1¼" x 9" NC - Gr 5 - Zinc	1
-	412420	-	Jam Nut -- 1¼" - 7 - Gr 2 - Zinc	2
-	413020	-	Flat Washer -- 1¼" - Zinc	1
5	450004	-	1/4" Drive-In Grease Fitting	1
6	800932	45	Gang Support Pivot - Taper Levee Plow - 2½" Dia. Rod	1
-	416133	-	Roll Pin -- 1/2" x 3½" - Zinc	1
7	800930	105	Gang Frame -- LH - Taper Levee Plow (Shown)	1
-	800929	105	Gang Frame -- RH - Taper Levee Plow	1
8	800937	5½	Outside Scraper – LH - Taper Levee Plow	3
-	800936	5½	Outside Scraper – RH - Taper Levee Plow	3
-	411785	-	Carriage Bolt -- 1/2" x 1½" NC - Gr 5 - Zinc	6
-	413508	-	Lock Washer -- 1/2" - Zinc	6
-	412008	-	Hex Nut -- 1/2" - 13 - Gr 2 - Zinc	6

0856 - 28 Blade Double Taper Levee Plow

GANG FRAME ASSEMBLY

(Continued)

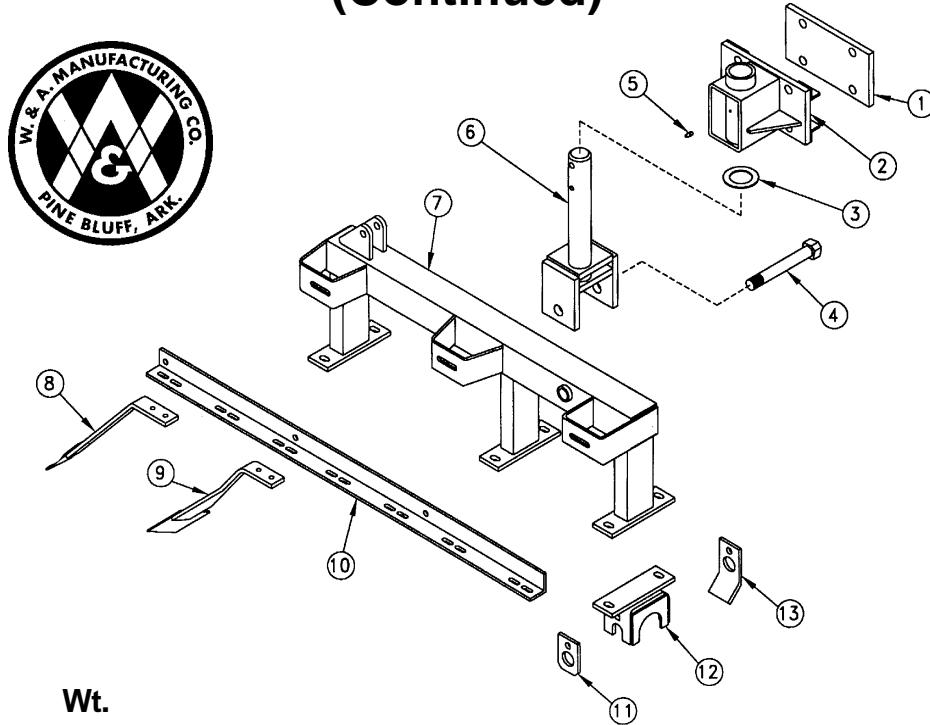

<u>Item No.</u>	<u>Part No.</u>	<u>Wt. Lbs.</u>	<u>Description</u>	<u>Qty. Req'd for 1 Gang</u>
9	800939	5½	Inside Scraper – LH - TLP (w/Twist in Leg)	4
-	800938	5½	Inside Scraper – RH - TLP (w/Twist in Leg)	4
-	411785	-	Carriage Bolt -- 1/2" x 1½" NC - Gr 5 - Zinc	8
-	413508	-	Lock Washer -- 1/2" - Zinc	8
-	412008	-	Hex Nut -- 1/2" - 13 - Gr 2 - Zinc	8
10	805106	27	Scraper Bar – LH - Taper Levee Plow	1
-	805105	27	Scraper Bar – RH - Taper Levee Plow	1
-	411790	-	Carriage Bolt -- 5/8" x 2" NC - Gr 5 - Zinc	3
-	413510	-	Lock Washer -- 5/8" - Zinc	3
-	412010	-	Hex Nut -- 5/8" - 11 - Gr 2 - Zinc	3
11	805094	1	Rear Trunion Clamp - Taper Levee Plow	3
-	411790	-	Carriage Bolt -- 5/8" x 2" NC - Gr 5 - Zinc	3
-	412010	-	Hex Nut -- 5/8" - 11 - Gr 2 - Zinc	3
-	413510	-	Lock Washer -- 5/8" - Zinc	3
12	800926	12½	Trunion Housing - Taper Levee Plow	3
-	411790	-	Carriage Bolt -- 5/8" x 2" NC - Gr 5 - Zinc	6
-	412010	-	Hex Nut -- 5/8" - 11 - Gr 2 - Zinc	6
-	413510	-	Lock Washer -- 5/8" - Zinc	6
13	805093	2½	Front Trunion Clamp - Taper Levee Plow	3
-	411790	-	Carriage Bolt -- 5/8" x 2" NC - Gr 5 - Zinc	3
-	412010	-	Hex Nut -- 5/8" - 11 - Gr 2 - Zinc	3
-	413510	-	Lock Washer -- 5/8" - Zinc	3

0856 - 28 Blade Double Taper Levee Plow

TAPERED GANG PARTS

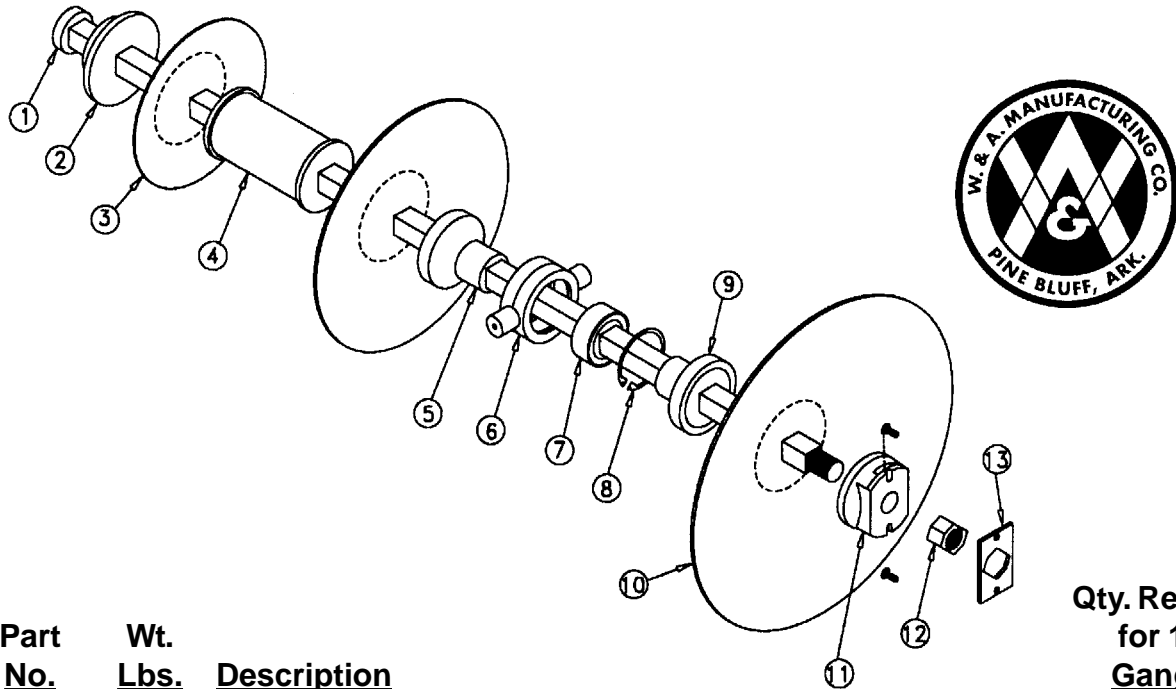

Item No.	Part No.	Wt. Lbs.	Description	Qty. Req'd for 1 Gang
1	478117	37	1½" Sq. x 57¾" NF Axle w/Nut (Taper Levee Plow)	1
2	802384	4¾	Bumper Washer - Levee Plow	1
3	473712	14	12" x 6.0MM RFC Plain Blade - 1½" Sq Ctr Hole	1
-	473714	6½	14" x 4.0MM RFC Plain Blade - 1½" Sq Ctr Hole	1
-	473716	9	16" x 4.0MM RFC Plain Blade - 1½" Sq Ctr Hole	1
-	473718	11½	18" x 4.5MM RFC Plain Blade - 1½" Sq Ctr Hole	1
-	473720	16	20" x 4.5MM RFC Plain Blade - 1½" Sq Ctr Hole	1
-	473722	19	22" x 4.5MM RFC Plain Blade - 1½" Sq Ctr Hole	1
4	800193	10½	Spacer Spool - 9" - Levee Plow	3
5	802005	7	Large End Bell - Levee Plow	3
6	802006	7	Bearing Housing - Levee Plow	3
-	450102	-	1/8" NPT Grease Fitting	3
-	505001	9½	Bearing & Housing Assembly - Levee Plow	3
7	481213	2½	Bearing - 1½" Sq. Bore - GW211PP3	3
8	483393	-	Retaining Ring - LP & 1½" Axle Bedder	3
9	802004	6	Small End Bell - Levee Plow	3
10	473230	41½	24" x 5/16" RFC PI Blade - 1½" Sq Ctr Hole	1
11	802256	6½	End Gang Washer - Levee Plow	1
12	412824	1	Hex Nut -- 1½" - 12 - Gr 5 - Zinc	1
13	802340	1	Lock Plate - Levee Plow	1
-	411711	-	Carriage Bolt -- 3/8" x 1" NC - Gr 2 - Zinc	2
-	413506	-	Lock Washer -- 3/8" - Zinc	2
-	412006	-	Hex Nut -- 3/8" - 16 - Gr 2 - Zinc	2