



HAWKINS



VERTISTRIP™ OWNER'S MANUAL

REVISED 10.25



This manual is applicable to: VertiSTRIP™

Record the model number and serial number of your VertiSTRIP™ along with date purchased:

MODEL NUMBER _____

SERIAL NUMBER _____

DATE PURCHASED _____

SERIAL NUMBER

The serial number plate is located on the frame to be readily available. It is suggested that your serial number and purchase date also be recorded above.

The serial number provides important information about your VertiSTRIP™ and may be required to obtain the correct replacement part. Always provide the model number and serial number to your Hawkins Ag dealer when ordering parts or anytime correspondence is made with Hawkins Ag.

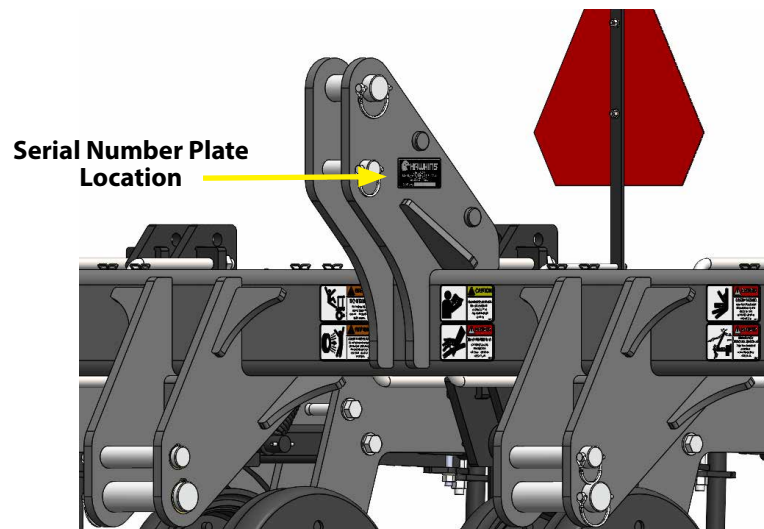



TO THE DEALER

Factory to Farm™ service includes full factory assembly. Dealer is responsible for field readiness.

PRE-DELIVERY CHECKLIST

Use the following checklist after your VertiSTRIP™ is completely assembled. Check off each item as it is found satisfactory or after proper adjustment is made.

- All working parts move freely, bolts are tight, and cotter pins are spread.
- Check for oil leaks and proper hydraulic operation.
- Hydraulic hoses correctly routed to prevent damage.
- Inflate tires to specified air pressure and torque wheel lug bolts and lug nuts as specified in the manual.
- All safety decals correctly located and legible. Replace if damaged.
- All reflective decals and SMV sign correctly located and visible when the machine is in transport position.
- Safety/warning lights correctly installed and working properly.
- Paint all parts scratched during shipment or assembly.
- All safety lockup devices on the VertiSTRIP™ are correctly located.

The VertiSTRIP™ has been thoroughly checked and to the best of my knowledge is ready for delivery to the customer.

(Signature Of Set-Up Person/Dealer Name/Date)

NAME _____ DELIVERY DATE _____

STREET ADDRESS _____ MODEL NO. _____ SERIAL NO. _____

CITY, STATE/PROVINCE _____ DEALER NAME _____

ZIP/POSTAL CODE _____ DEALER NO. _____



DELIVERY CHECKLIST

Use the following checklist after your VertiSTRIP™ is delivered as a reminder of very important information which should be conveyed to retail customer/end user. Check off each item as it is fully explained.

- Life expectancy of this or any other machine is dependent on regular lubrication as directed in the Owner's Manual.
- All applicable safety precautions.
- Along with retail customer/end user, check reflective decals and SMV sign are clearly visible with VertiSTRIP™ in transport position and attached to tractor. Check safety/warning lights are in working condition. Tell retail customer/end user to check federal, state/provincial, and local regulations before towing or transporting on a road or highway.
- Give Owner's Manual and all Instruction Sheets to retail customer/end user and explain all operating adjustments.
- Read warranty to retail customer/end user.
- Complete Warranty and Delivery Report form.

To the best of my knowledge, this machine has been delivered ready for field use and customer has been fully informed as to proper care and operation.

(Signature Of Set-Up Person/Dealer Name/Date)

AFTER DELIVERY CHECKLIST

The following is a list of items we suggest to check during the first season of use of the equipment.

- Check VertiSTRIP™ performance with retail customer/end user.
- Review importance of proper maintenance and adherence to all safety precautions with retail customer/end user.
- Check for parts that may need to be adjusted or replaced.
- Check all safety decals, reflective decals, and SMV sign are correctly located as shown in the Parts Guide and that decals are legible. Replace if damaged or missing.
- Check safety/warning lights are functioning properly.

(Signature Of Set-Up Person/Dealer Name/Date)

All registrations must be submitted to AGROdeviate within 5 business days of delivery. Retain a copy of this form for auditing purposes.

All registrations must be submitted to:

AGROdeviate
PO BOX 2618
Kearney, NE 68848



GENERAL INFORMATION	
HOW TO USE THIS MANUAL.....	1
WARRANTY INFORMATION	2
SAFETY	3
SIGNAL WORDS.....	3
EQUIPMENT SAFETY GUIDELINES	4
SAFETY	
SAFETY SIGN LOCATIONS.....	5
SAFETY SIGN CARE.....	10
PREPARATION & SET-UP	
POST DELIVERY/SEASONAL/PRE-TILLAGE SET-UP	11
CHECK/CHANGE HITCH CONFIGURATION	12
HITCHING TRACTOR TO IMPLEMENT.....	14
HYDRAULIC HOSE HOOK-UP	15
LIGHT KIT GUIDE AND RELOCATION	16
ELECTRICAL HOOK-UP	17
AIR COMPRESSOR.....	18
AIR CONTROLLER	19
LEVELING THE IMPLEMENT	21
OPERATION	
BEFORE FIRST USE	23
WING LOCK PINS	25
FOLDING/UNFOLDING FUNCTION.....	26
TRANSPORT CHECKLIST	28
LEVELING THE MACHINE	29
GAUGE WHEEL ADJUSTMENT	30
ROW UNIT AIR DOWNFORCE.....	31
TRAILBLAZER™ ROW CLEANERS	34
FRONT COULTER DEPTH ADJUSTMENT	41
OPTIMIZER™ FINISHING SYSTEM.....	42
ROW CONFIGURATIONS	45
COULTER MACHINE	46
REAR COULTER ADJUSTMENT.....	47
KNIFE MACHINE	49
REAR KNIFE ADJUSTMENT.....	50
FLEXBERM™.....	52
HYDRAULIC TRIPPING SYSTEM.....	57
DUAL PLACEMENT LIQUID.....	60
BAR STANDS.....	64
OPERATING TIPS	65
PARKING	67
AFTER OPERATION	68
DO'S AND DON'TS	69
TROUBLESHOOTING	
TROUBLESHOOTING	70
MAINTENANCE & LUBE	
GENERAL MAINTENANCE	76
MAINTENANCE SCHEDULE	77
BLEEDING FOLD HYDRAULICS	78
BOLT TORQUE CHART	79
HYDRAULIC FITTING IDENTIFICATION	80
PARTS GUIDE	
INDEX.....	82
ROW CLEANERS.....	83
FINGER BLADES	85



PARTS GUIDE CONT.

MOUNTS & PARALLEL LINKAGES86
AIR DOWNFORCE88
DEPTH WHEELS90
SHANK HOUSING92
DUAL COULTER ASSEMBLY94
COULTERS95
OPTIMIZER BASKET96
IRON TIRES98
FLEXBERM MOUNT99
FLEXBERM ARM101
HYDRAULIC TRIP CYLINDER.....103
HYDRAULIC TRIP ROW UNIT105
HYDRAULIC TRIP - MANIFOLD TO TRACTOR107
KNIFE ADAPTER108
LIQUID ADAPTER110
AIR CONTROLLER/AIR SYSTEM112



GENERAL INFORMATION



HOW TO USE THIS MANUAL

This manual is divided into sections. The first section contains a Table of Contents, General Information, and a Part Number Index. The remaining sections divide the machine into assemblies and sub-assemblies which illustrate and list all parts.

Hawkins Ag parts in this manual are specially designed for this machine and should be replaced with Hawkins Ag parts only.

Information in this manual was current at time of printing. However, due to Hawkins Ag's ongoing product improvement, production changes may cause your machine to appear slightly different in detail. Hawkins Ag reserves the right to change specifications or design without notice and without incurring obligation to install the same on machines previously manufactured.

Right-hand and left-hand as used in this manual are determined by facing the direction the machine will travel while in use.

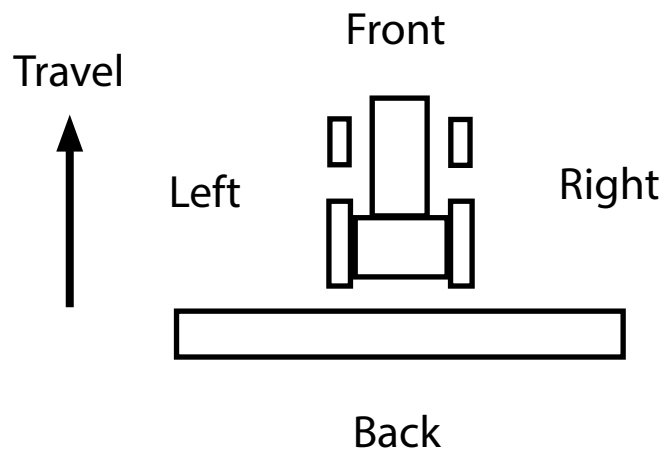

MANUAL REPLACEMENT INFORMATION

Replacement manuals are available. Call the Hawkins Ag Main Office at 308.708.8185, or download a printable PDF from our website, www.hawkinsag.com.

MANUAL REVISIONS

When this manual is revised, the modification date is printed on the front cover and on the revised page(s).



INTRODUCTION

Thank you for your purchase of a Hawkins Ag VertiSTRIP™. Putting your trust in our equipment is something we don't take lightly and are humbled that you chose Hawkins Ag. Having designed all of our equipment with farmers like you in mind, we hope you enjoy years of productive use from it. Please read and understand this manual before operation.

WARRANTY INFORMATION

AGROdeviate LLC (AGROdeviate) warrants each Hawkins Ag product it manufactures to be free from defects in material and workmanship for a period not to exceed one (1) year from the date of sale to the original owner. The warranty is valid provided written notice of the alleged defect is received by AGROdeviate during said period and within ten (10) working days after its discovery.

In addition, AGROdeviate warrants each TOOLBAR FRAMEWORK to be free from defects in material and workmanship for a period not to exceed three (3) years from the date of sale to the original owner. The warranty is valid providing written notice of the alleged defect is received by AGROdeviate during said period and within ten (10) working days after its discovery.

This warranty is subject to completion of Product Registration and submission to AGROdeviate. Warranty applies only if product is installed, operated, and maintained according to product manual and instructions. Warranty will be void if the product has been subject to misuse, misapplication, neglect, collision with obstruction, or alteration.

For products, parts, and components NOT manufactured by AGROdeviate, the warranty obligations of AGROdeviate shall be limited to the Original Equipment Manufacturers' warranty. Tires on AGROdeviate equipment are warranted through the respective tire manufacturer and their network of dealers.

All returns must be pre-approved by AGROdeviate and authorization issued before return. All returns must include a copy of the original invoice in order to be processed. Any returns without a copy of the original invoice will not be eligible to receive credit.

If determined that the product is defective in material and/or workmanship, the necessary parts will be replaced and/or repaired. All warranty repair or labor is to be performed by an AGROdeviate authorized party. AGROdeviate obligation under this warranty shall be limited to repairing or replacing parts deemed defective. Warranty does not cover travel expenses. AGROdeviate will bear no other costs including loss, incurred labor, rental fees, nor other.

All returns shall be pre-paid. If warranty is approved by AGROdeviate, return freight will be credited.

This warranty by AGROdeviate LLC is expressly in lieu of all other warranties, expressed or implied, including warranty of merchantability and fitness for use. We neither assume, nor authorize, any other entity to accept for us any liability relating to the sale of our products.



SAFETY

TAKE NOTE! THIS SAFETY ALERT SYMBOL FOUND THROUGHOUT THIS MANUAL IS USED TO CALL YOUR ATTENTION TO INSTRUCTIONS INVOLVING YOUR PERSONAL SAFETY AND THE SAFETY OF OTHERS. FAILURE TO FOLLOW THESE INSTRUCTIONS CAN RESULT IN INJURY OR DEATH.



**THIS SYMBOL MEANS:
-ATTENTION!
-BECOME ALERT!
-YOUR SAFETY IS INVOLVED!**

SIGNAL WORDS: Note the use of signal words DANGER, WARNING, and CAUTION with the safety messages. The appropriate signal word for each has been selected using the following guidelines:



DANGER: Indicates an imminently hazardous situation that, if not avoided, will result in death or serious injury. This signal word is to be limited to the most extreme situations typically for machine components which, for functional purposes, cannot be guarded.



WARNING: Indicates a potentially hazardous situation that, if not avoided, could result in death or serious injury, and includes hazards that are exposed when guards are removed. It may also be used to alert against unsafe practices.



CAUTION: Indicates a potentially hazardous situation that, if not avoided, may result in minor or moderate injury. It may also be used to alert against unsafe practices.

If you have questions not answered in this manual, require additional copies, or the manual is damaged, please contact AGROdeviate, AGROdeviate, LLC PO BOX 2618 Kearney, NE 68848, 308.708.8185, or visit our website: www.hawkinsag.com.



SAFETY... YOU CAN LIVE WITH IT!



EQUIPMENT SAFETY GUIDELINES

Safety of the operator is one of the main concerns in designing and developing a new piece of equipment. Designers and manufacturers build in as many safety features as possible. However, every year many accidents occur which could have been avoided by a few seconds of thought and a more careful approach to handling equipment. You, the operator, can avoid many accidents by observing the following precautions in this section. To avoid personal injury, study the following precautions and insist those working with you, or for you, follow them.

In order to provide a better view, certain photographs or illustrations in this manual may show an assembly with a safety shield removed. However, equipment should never be operated in this condition. Keep all shields in place. If shield removal becomes necessary for repairs, replace the shield prior to use.

Replace any CAUTION, WARNING, DANGER or instruction safety decal that is not readable or is missing. Location of such decals is indicated in this booklet.

Do not attempt to operate this equipment under the influence of drugs or alcohol.

Review the safety instructions with all users annually.

This equipment is dangerous to children and persons unfamiliar with its operation. The operator should be a responsible adult familiar with farm machinery and trained in this equipment's operations. Do not allow persons to operate or assemble the unit until they have read this manual and have developed an understanding of the safety precautions and how it works.

To prevent injury or death, use a tractor with a Rollover Protective Structure (ROPS). Do not paint over, remove or deface any safety signs or warning decals on your equipment. Observe all safety signs and practice the instructions on them.

Never exceed the limits of a piece of machinery. If its ability to do a job, or to do so safely, is in question - DON'T TRY IT.



SAFETY SIGN LOCATIONS

These types of Safety Signs and locations on the equipment are shown in the illustrations below. Good safety requires that you familiarize yourself with the various Safety Signs, the type of warning and the area, or particular function related to that area, that require your SAFETY AWARENESS.

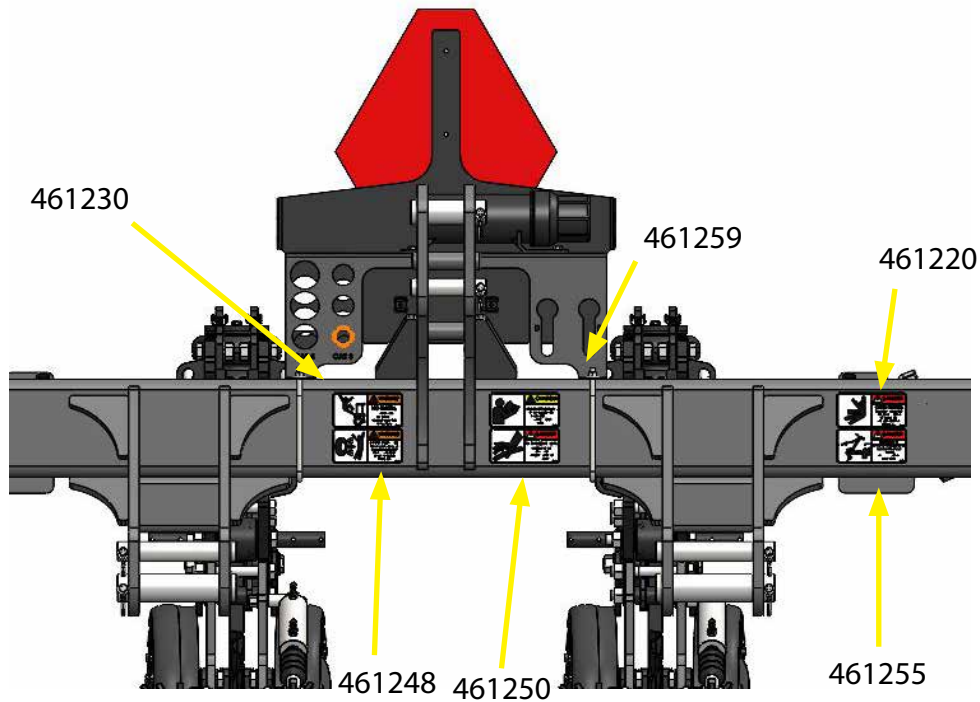

NOTE: LH/RH Safety Signs and locations are similar

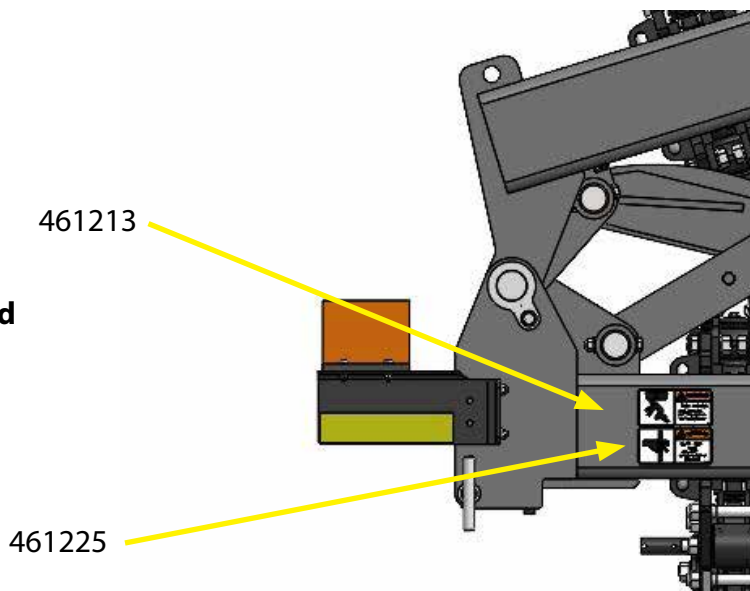

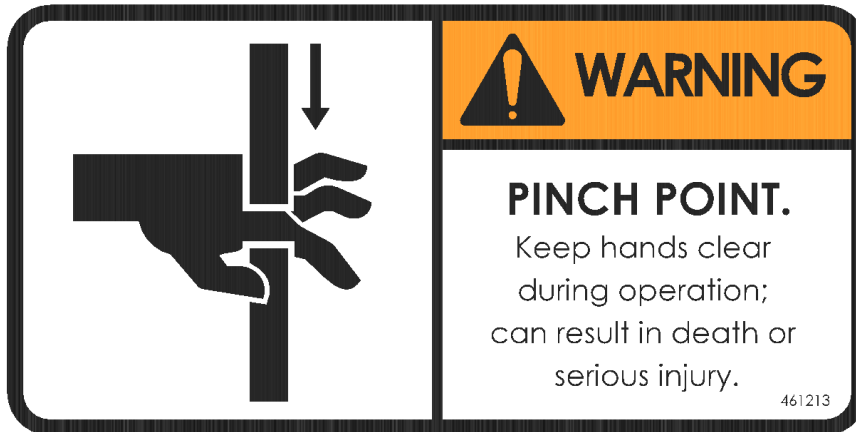

461213

PINCH POINT - WARNING

- Keep extremities clear of equipment. Object(s) can move or shift; can result in death or serious injury.
- Hazards may include, but are not limited to, hinge mechanism movement, pin movement, row unit movement and shifting, accessory movement and shifting, etc.

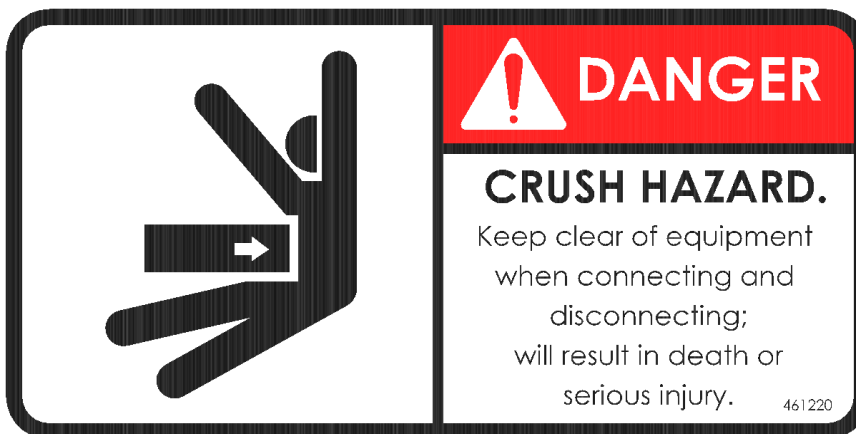

461220

CRUSH HAZARD - DANGER

- Keep clear of moving and shifting equipment. Equipment movement area; will result in death or serious injury.
- Hazards may include, but are not limited to, connection and disconnection of equipment, unexpected equipment shifting, etc.

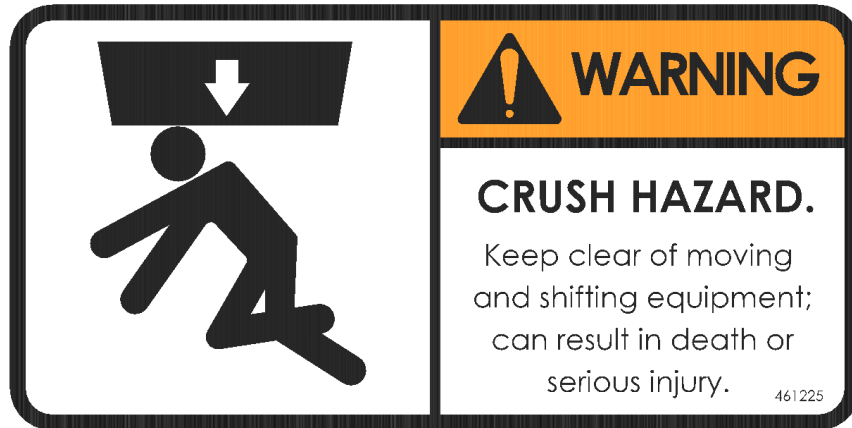

461225

CRUSH HAZARD - WARNING

- Keep clear of moving and shifting equipment. Equipment can move or shift; can result in death or serious injury.
- Hazards may include, but are not limited to, folding wing movement, raised equipment movement and shifting, etc.



461230

NO RIDERS - WARNING

- Never allow riders on equipment; can result in death or serious injury.
- Hazards may include, but are not limited to, falling from equipment, falling into equipment, injury while on equipment, etc.



461248

CONTENTS UNDER PRESSURE - WARNING

- Do not operate if damaged or improperly pressurized. Damaged or improperly pressurized components can discharge; can result in death or serious injury.
- Hazards may include, but are not limited to, damaged tire and/or rim, over pressurized tire, excessive tire wear, tire tears or punctures, ect.



461250

HIGH PRESSURE FLUID - DANGER

- Use safe practices. Fluid injection can occur; will result in death or serious injury.
- Hazards may include, but are not limited to, injury beyond the entry point, over pressurized components, damaged components, components with excessive wear, swollen components, ect.

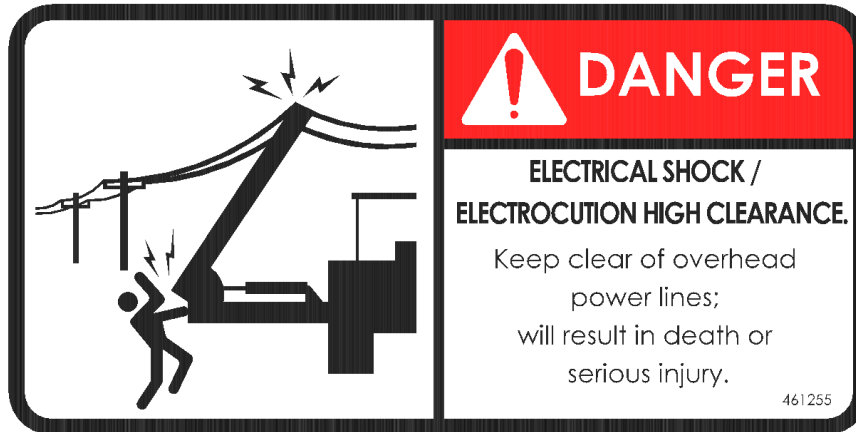

461255

ELECTRICAL SHOCK/ELECTROCUTION HIGH-CLEARANCE - DANGER

- Keep clear of overhead power lines, maintain 20-foot minimum distance. Electrical shock and/or electrocution can occur; will result in death or serious injury.
- Hazards may include, but are not limited to, high clearance equipment, low clearance power lines, lack of awareness of surroundings, etc.

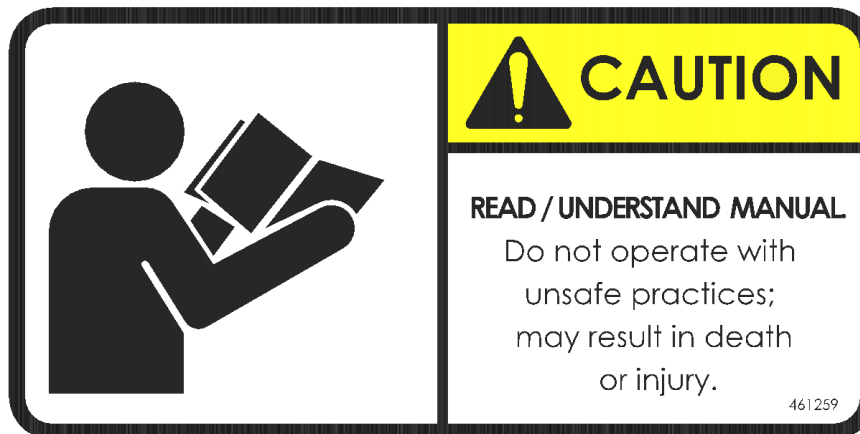

461259

READ/UNDERSTAND MANUAL - CAUTION

- Do not operate without a complete understanding of the owner's manual. Do not operate with unsafe practices; may result in death or injury.
- Hazards may include, but are not limited to, compromising the safety of yourself and/or others, lack of awareness, damage to equipment, etc.



SAFETY SIGN CARE

- Keep safety signs clean and legible at all times.
- Replace safety signs that are missing or have become illegible.
- Replaced parts that displayed a safety sign should also display the current sign.
- Safety signs are available from Hawkins Ag.

HOW TO INSTALL SAFETY SIGNS

- Be sure that the installation area is clean and dry.
- Decide on the exact position before you remove the backing paper.
- Remove the smallest portion of the split backing paper.
- Align the decal over the specified area and carefully press the small portion with the exposed stick backing in place.
- Slowly peel back the remaining paper and carefully smooth the remaining portion of the decal in place.
- Small air pockets can be pierced with a pin and smoothed out using the piece of decal backing paper.

REMEMBER: If Safety Signs have been damaged, removed, become illegible or parts replaced without decals, new decals must be applied. New decals are available from Hawkins Ag.

**AGROdeviate, LLC
PO BOX 2618
Kearney, NE 68848**

**308.708.8185
www.hawkinsag.com**

PREPARATION & SET-UP



This section helps you prepare your tractor and VertiSTRIP™ for use. You must level the implement, hook up the implement hydraulics to the tractor, and check that the hydraulics have been bled.

POST-DELIVERY/SEASONAL SET-UP

On initial delivery, use with a new tractor, and seasonally check and as necessary, complete these items before continuing to the routine set-up items:

- Bleed hydraulic fold system (page 63)
- Check/Change Hitch Configuration
- Hitching Tractor to Implement
- Hydraulic Hose Hook-up
- Light Kit Guide and Relocation
- Electrical Hook-up
- Leveling the Implement

PRE-TILLAGE SET-UP

Complete this checklist before routine set-up:

- Read and understand important "Safety" information starting on page 3.
- Check that all working parts are moving freely, bolts are tight, and cotter pins are spread.
- Check that all grease fittings are in place and lubricated. See "Maintenance & Lube" on page 61.
- Check that all safety decals and reflectors are correctly located and legible. Replace if damaged. See "Safety Sign Locations" starting on page 5.

PREPARATION & SET-UP



CHECK/CHANGE HITCH CONFIGURATION

On initial delivery, use with a new tractor, and seasonally check and as necessary, complete these items before continuing to the routine set-up items:

Choose a hitch option that is compatible with your tractor 3-point. The VertiSTRIP™ has two hitch configurations:

- Category 3
- Category 4

Changing between hitch categories requires removing pins at the implement hitch.

TO OPERATE AS CATEGORY 3

1. Remove and store the Category 4 pins.

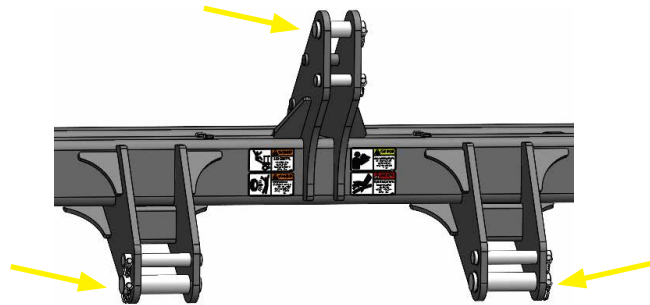

2. Once removed, the remaining pins are set to run the implement with a Category 3 hitch.

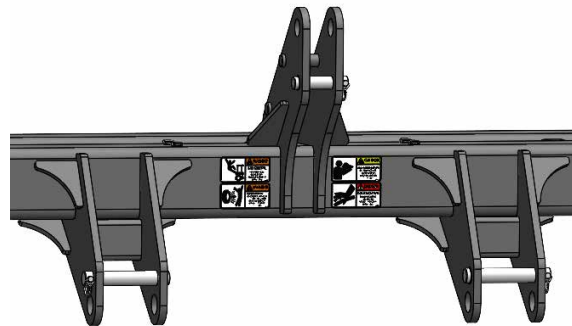

****SEE NEXT PAGE FOR CATEGORY 4 HITCH SET-UP****

PREPARATION & SET-UP



TO OPERATE AS CATEGORY 4

1. Remove and store the Category 3 pins.

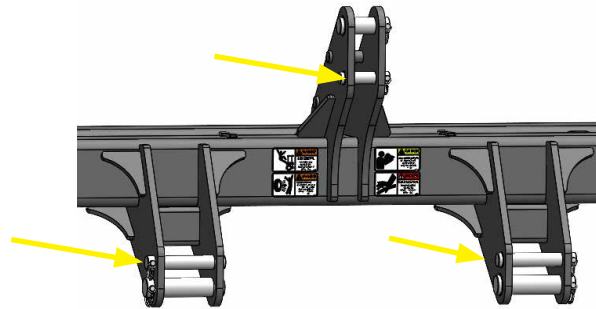

2. Once removed, the remaining pins are set to run the implement with a Category 4 hitch.

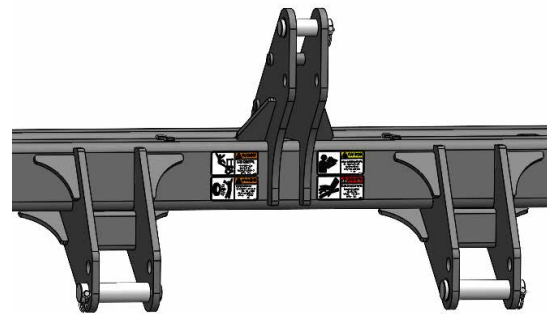

PREPARATION & SET-UP



HITCHING TRACTOR TO IMPLEMENT

On initial delivery, use with a new tractor, and seasonally check and as necessary, complete these items before continuing to the routine set-up items:

1. Connect the tractor 3-point lift arms to the lower hitch pins. If using a quick hitch, ensure that the pins lock securely.
2. Connect the top link to the upper hitch pin. Front-to-back leveling is performed in later steps.

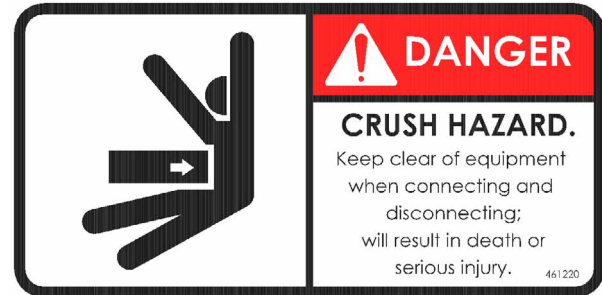

461220

CRUSH HAZARD - DANGER

- Keep clear of moving and shifting equipment. Equipment movement area; will result in death or serious injury.
- Hazards may include, but are not limited to, connection and disconnection of equipment, unexpected equipment shifting, etc.

PREPARATION & SET-UP



HYDRAULIC HOSE HOOK-UP

The VertiSTRIP™ is equipped with independently controlled fold cylinders to individually fold the left and right wings.

This requires the use of two remote valves. Hoses at base end of cylinder will unfold machine. Rod end hoses will fold machine up.

1. Connect fold hoses for left wing into remote valve of choice.
2. Connect fold hoses for right wing into remote valve of choice.
3. If your machine is equipped with hydraulic tripping function, connect hoses from tripping manifold to remote valve of choice.
4. Check and make sure all hoses are tied up and secure before use.



461250

HIGH PRESSURE FLUID - DANGER

- Use safe practices. Fluid injection can occur; will result in death or serious injury.
- Hazards may include, but are not limited to, injury beyond the entry point, over pressurized components, damaged components, components with excessive wear, swollen components, ect.



LIGHT KIT GUIDE AND RELOCATION

The light kit is installed at the factory. However, due to shipping requirements and other circumstances, some positions are altered and SMV sign or lights may need relocated before use. Typically, the SMV sign is the only component that needs relocated; please check all components. Check that all forward-facing reflectors and lights are visible from the front and all rear-facing reflectors and lights are visible from the rear. Please refer to the depiction below for component locations.

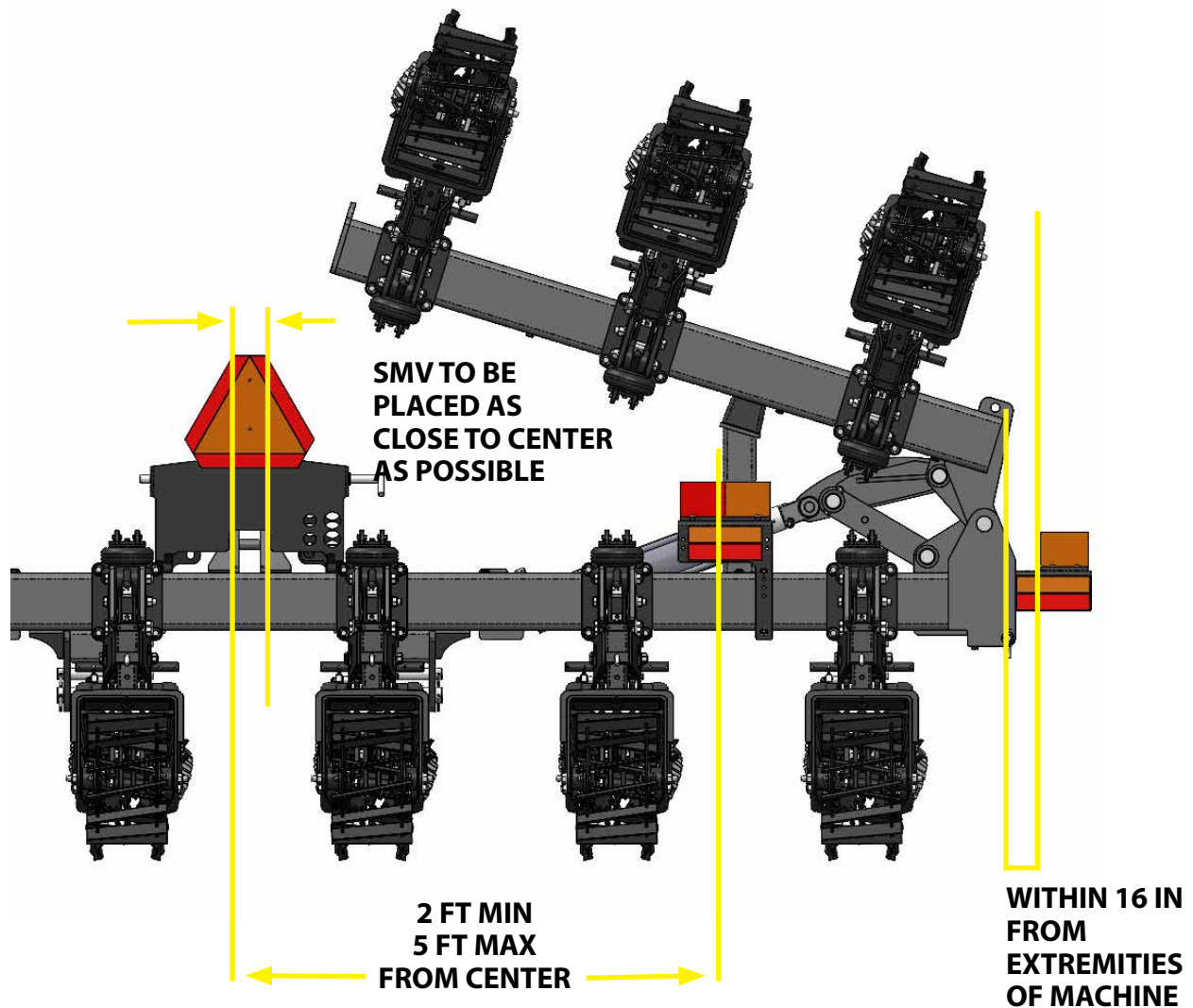



ELECTRICAL HOOK-UP

Lights are connected using a standard 7-pin connector. To connect, simply lift receptacle cover, align plug and insert. To disconnect, lift receptacle cover and remove plug. Once connected, check to make sure all lights are working properly. If lights are not working properly, contact your dealer to fix before transporting on public roadways.

7-pin Connector



PREPARATION & SET-UP



AIR COMPRESSOR

ELECTRICAL HOOK-UP

Please see included Air Compressor Manual for installation instructions.





AIR CONTROLLER



Shown to the left is the Hawkins VertiSTRIP™ air controller. It has the ability to control all of the pneumatic functions on the Hawkins VertiSTRIP™.

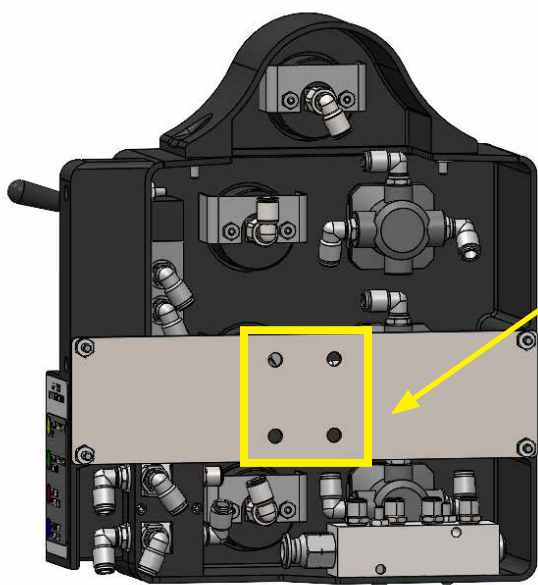

Included on the rear of the air controller is a steel plate with a hole pattern for mounting inside of the cab. This pattern is industry-standard AMPS hole pattern (1.19" x 1.5" square and 1/4" holes). It is recommended to use either a RAM style mount or use the tractor accessory rail. Additional adapters may be required.

Due to the wide variety of cab mounting options available please see (<https://rammount.com/>) for more quality options.



AIR CONTROLLER

It is recommended to mount the Hawkins Air Controller in the inside of the cab on the right-hand side.

The Hawkins Air Controller will attach to air lines from the toolbar. These air lines will need to be run inside of the cab. Once in the cab, they will meet up with an air line of matching size and color.

There are 3 additional black lines on the air controller that should be routed out of the cab, these are air exhaust lines. The intended use of each air line is also indicated on the side of the air controller. Make sure to secure any extra line in a safe spot to prevent any damage.

AIR LINES COMING FROM MACHINE:

- $\frac{3}{8}$ Black Line, supply pressure from Air Compressor
- $\frac{1}{4}$ Yellow Line, Row Cleaner Up
- $\frac{1}{4}$ Green Line, Row Cleaner Down
- $\frac{1}{4}$ Red Line, Basket Down Pressure
- $\frac{1}{4}$ Blue Line, Row Unit Pressure

AIR LINES FROM AIR CONTROLLER:

- $\frac{3}{8}$ Black Line, supply pressure from Air Compressor
- $\frac{1}{4}$ Yellow Line, Row Cleaner Up
- $\frac{1}{4}$ Green Line, Row Cleaner Down
- $\frac{1}{4}$ Red Line, Basket Down Pressure
- $\frac{1}{4}$ Blue Line, Row Unit Pressure
- 3x $\frac{1}{4}$ Black Lines, Exhaust air (route to outside of cab)

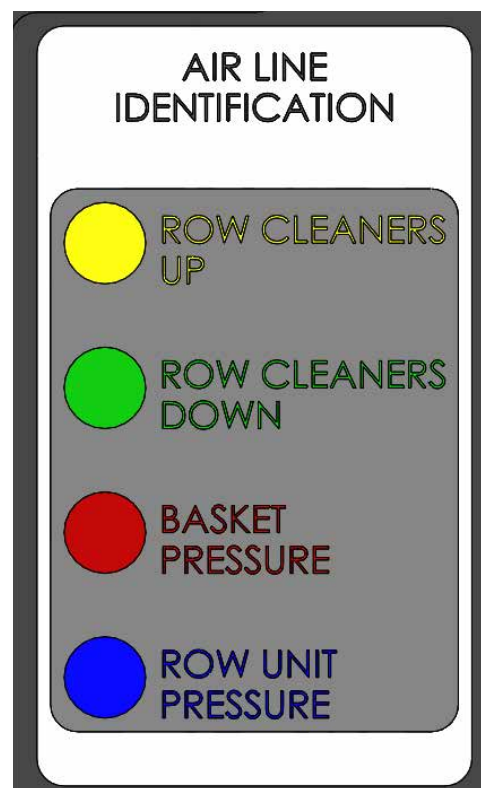



LEVELING THE IMPLEMENT

Center Frame L/R Leveling (Figure 1)

1. Hitch the VertiSTRIP™ to a tractor (page 14).
2. Raise the implement.
3. Adjust the tractor 2-point lift arms so that the center section tool bar is level.

Figure 1

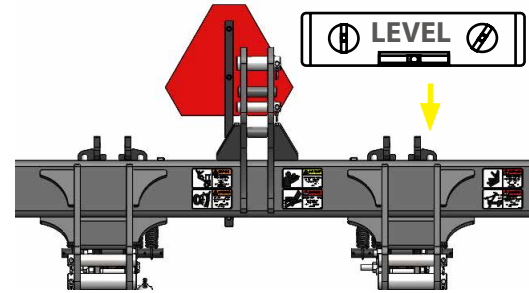

Wing Leveling (Figure 2 & 3)

1. Remove wing lock pins from the lock position, and place in the non-locking position before folding the wings.
2. Check wing for level at the top of the tool bar.
3. Fold implement to access leveling bolts.
4. If wing is too high, tighten bolts in 1/4-1/2" turn increments, unfolding machine to re-check level. If wing is too low, loosen bolts in 1/4-1/2" turn increments, unfolding machine to re-check level.
5. Repeat process until wing is level.

Figure 2

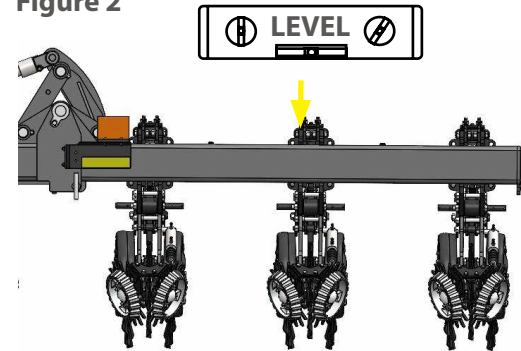
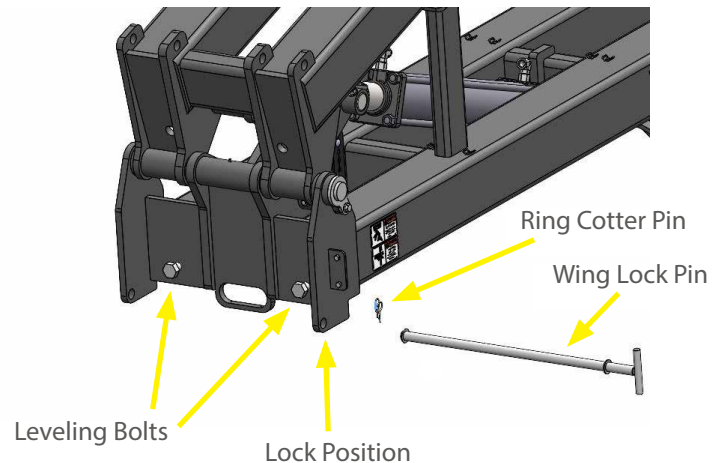

Figure 3



Front-to-Back Leveling

See "Leveling the Machine" on page 29. This adjustment needs to be completed in field conditions.



WARNING

CRUSH HAZARD - WARNING

- Keep clear of moving and shifting equipment. Equipment can move or shift; can result in death or serious injury.
- Hazards may include, but are not limited to, folding wing movement, raised equipment movement and shifting, etc.



NOTE: This page is intentionally left blank.



REMEMBER

Your best assurance against accidents is a careful and responsible operator. If there is any portion of this manual or function you do not understand, contact Hawkins Ag.



BEFORE OPERATION

- Carefully study and understand this manual.
- Do not wear loose-fitting clothing which may catch in moving parts.
- Always wear protective clothing and substantial shoes.
- It is recommended that suitable eye protection be worn.
- The operator may come in contact with certain materials which may require specific safety equipment (ie: extremely dusty, molds, fungus, bulk fertilizers).
- Keep bolts tightened to specific torque listed on **Bolt Torque Chart**.
- Give the unit a visual inspection for any loose bolts, worn parts or cracked welds, and make necessary repairs. Follow the maintenance safety instructions included in this manual.
- Be sure that there are no tools lying on or near the equipment.
- Do not use the unit until you are sure that the area is clear, especially children and animals.
- Because it is possible that this equipment may be used in dry areas or in the presence of combustibles, special precautions should be taken to prevent fires and fire fighting equipment should be readily available.
- Don't hurry the learning process or take the unit for granted. Ease into it and become familiar with your new equipment.
- Practice operation of your equipment and its attachments. Completely familiarize yourself and other operators with its operation before using.



DURING OPERATION

- Keep hands, feet, and clothing clear of moving parts.
- Do not clean, lubricate or adjust your equipment while it is moving.
- Be especially observant of the operating area and terrain - watch for holes, rocks or other hidden hazards. Always inspect the area prior to operation.
- Periodically clear the equipment of brush, twigs or other materials to prevent buildup of dry combustible materials.
- Do not walk or work under raised components or attachments unless securely positioned and blocked.
- Keep all bystanders, pets and livestock clear of the work area.
- Never stand alongside of unit with engine running or attempt to start engine and/or operate machine while standing alongside of unit.
- As a precaution, always recheck the hardware on equipment following every 100 hours of operation. Correct all problems. Follow the maintenance safety procedures.



This section covers general operating procedures. Experience, machine familiarity, and the following information will lead to efficient operation and good working habits. Always operate farm machinery with safety in mind.

PRE-START CHECKLIST

Perform the following steps before transporting the VertiSTRIP™ to the field.

- Carefully read "Important Safety Information" on page 3.
- Lubricate implement as indicated under "Maintenance & Lube" on page 61.
- Check all tires for proper inflation.
- Check all bolts, pins, and fasteners. Torque as shown in "Bolt Torque Chart" on page 64.
- Check implement for worn or damaged parts. Repair or replace parts before going to the field.
- Check hydraulic hoses, fittings, and cylinders for leaks. Repair or replace before going to the field.
- Perform all beginning-of-season and daily service items under "Maintenance & Lube" on page 61.



WING LOCK PINS

Remove the wing lock pins from the lock position and place in the hitch hub before folding the wing(s). To move wing lock pin position, pull ring cotter pin. Then, pull the pin out of the toolbar and reinsert it into the desired place. Insert the ring cotter pin.

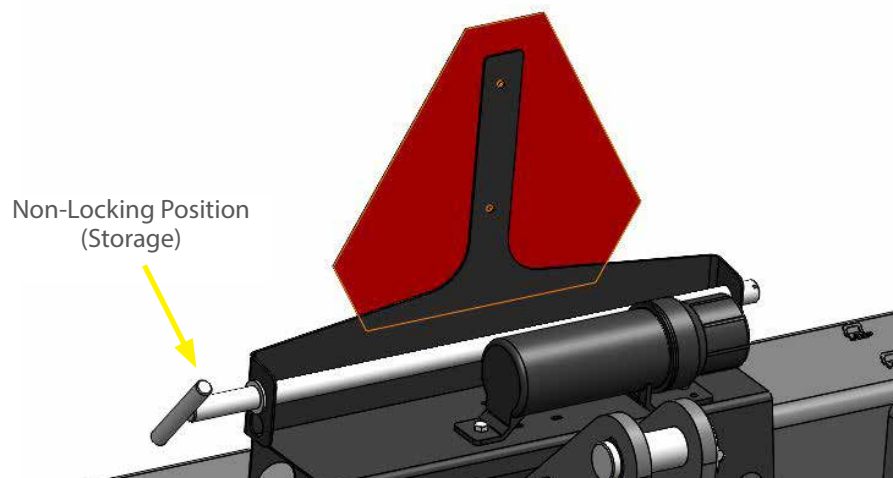
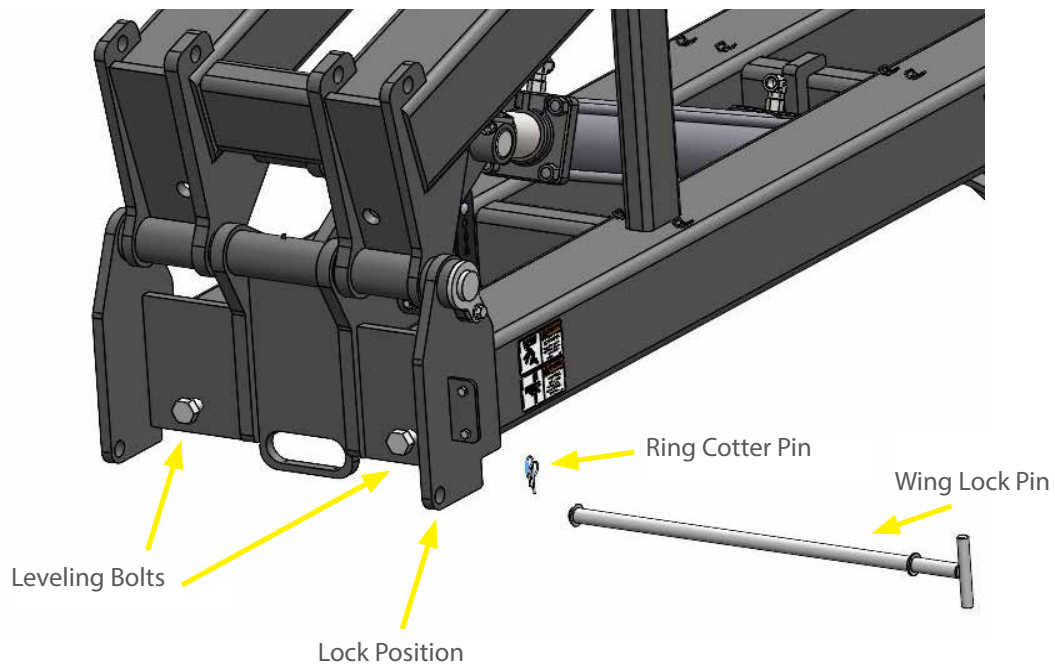



FOLDING

Fold the implement for movements on public roads and between fields and narrow clearances. Do not use the folded configuration for parking or storage.

1. Hitch tractor (page 14).
2. Move to level ground. Be aware of vertical clearance needed to fold implement.
3. Put tractor in Park with parking brake engaged.
4. Verify that the wing lock pins are not installed in the lower lock holes (page 25).
5. Clear all persons from on or near the implement.
6. Use the tractor 3-point hitch to raise the implement slightly (so that the row units are off the ground).
7. Slowly move fold circuit lever(s) to retract cylinders. Observe the fold operation.
8. Wait for both wings to reach the fully folded position. Set tractor remote(s) to Neutral to hold at folded.

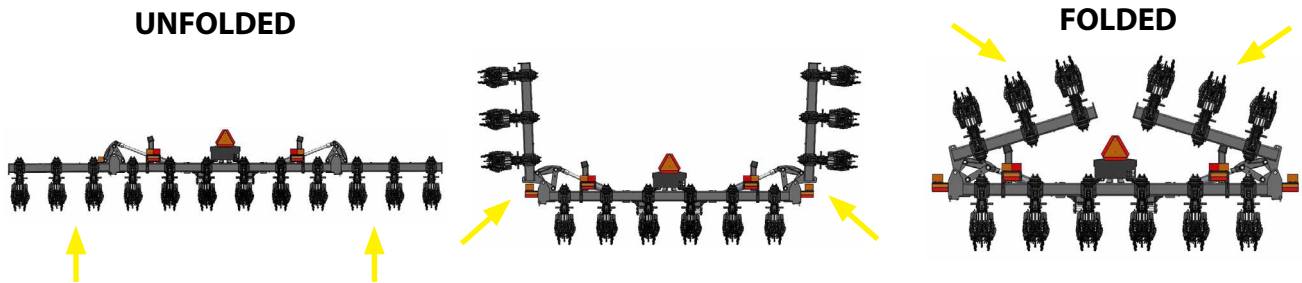

TIP OVER/CRUSHING HAZARD AND EQUIPMENT DAMAGE RISK:
Never unhitch a folded implement. A folded implement could topple backward or forward, causing serious injury or death and certain severe equipment damage. When unhitched, the implement is supported at the rear only by row unit tools and spring tension. Slopes, soft soils, and soils later softened by rain are particularly dangerous.



ELECTRICAL SHOCK/ELECTROCUTION HIGH-CLEARANCE DANGER:
Keep clear of overhead power lines, maintain 20-foot minimum distance. Electrical shock and/or electrocution can occur; will result in death or serious injury. Hazards may include, but are not limited to, high clearance equipment, low clearance power lines, lack of awareness of surroundings, etc.



CRUSH HAZARD - WARNING:
Keep clear of moving and shifting equipment. Equipment can move or shift; can result in death or serious injury. Hazards may include, but are not limited to, folding wing movement, raised equipment movement and shifting, etc.



UNFOLDING

Unfold the implement for adjustments, field operations, maintenance, parking and storage.

1. Unless the implement was folded, with the currently hitched tractor, only a short time ago, check for evidence of oil leaks. Check the ground at hitch connections, hose fittings and under cylinders.
2. Be aware of vertical and horizontal clearances needed to unfold the implement.
3. Put tractor in Park with parking brake engaged.
4. Verify that the wing lock pins are not installed in the lower lock holes (page 25).
5. Clear all persons from on or near the implement.
6. Use the tractor 3-point hitch to raise the implement slightly (so that the row units are off the ground).
7. Slowly move fold circuit lever(s) to Extend cylinders. Observe the unfold operation.
8. Wait for both wings to reach the fully unfolded position. Set tractor remote(s) to Neutral to lock at unfolded.

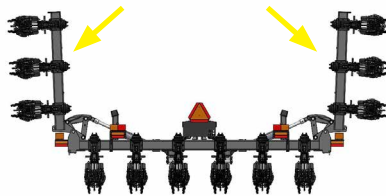
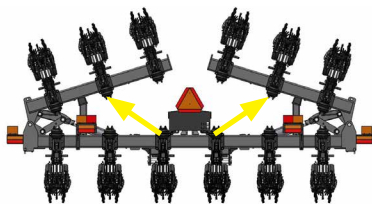

TIP OVER/CRUSHING HAZARD AND EQUIPMENT DAMAGE RISK:

Never unhitch, park, or store a partially folded implement. A partially folded implement could topple backward or forward immediately or at a later time, causing serious injury or death and certain severe equipment damage. When unhitched, the implement is supported at the rear only by row unit tools and spring tension. Slopes, soft soils, and soils later softened by rain are particularly dangerous.



ELECTRICAL SHOCK/ELECTROCUTION - HIGH-CLEARANCE DANGER:

Keep clear of overhead power lines, maintain 20-foot minimum distance. Electrical shock and/or electrocution can occur; will result in death or serious injury. Hazards may include, but are not limited to, high clearance equipment, low clearance power lines, lack of awareness of surroundings, etc.



EQUIPMENT DAMAGE RISK:

Do not leave a partially folded implement lifted for extended periods of time. This places a needless unbalance load on the tractor's lower lift arms.



CRUSH HAZARD - WARNING

Keep clear of moving and shifting equipment. Equipment can move or shift; can result in death or serious injury. Hazards may include, but are not limited to, folding wing movement, raised equipment movement and shifting, etc.



TRANSPORT CHECKLIST

Before transporting the implement, check the following items.

- Transport only with a tractor of proper size and adequate ballast.
- Hitch implement securely to tractor. See “Hitching Tractor to Implement” on page 14.
- Plug implement safety lights into tractor seven-pin connector.
- Make sure implement is folded properly. See “Folding” on page 26. Raise the implement for adequate ground clearance.
- Comply with all national, regional, and local safety laws when traveling on public roads.
- Travel with caution.



LOSS OF CONTROL HAZARD:

Ensure that the towing vehicle is adequate for the task. Using an inadequate tow vehicle is extremely unsafe, and can result in loss of control, serious injury and death. To reduce the hazard, use only a 3-point towing vehicle that is both rated for the implement load, and properly ballasted for the load.



ELECTRICAL SHOCK/ELECTROCUTION HIGH-CLEARANCE DANGER:

Keep clear of overhead power lines, maintain 20-foot minimum distance. Electrical shock and/or electrocution can occur; will result in death or serious injury. Hazards may include, but are not limited to, high clearance equipment, low clearance power lines, lack of awareness of surroundings, etc.



BRAKING AND LOSS OF CONTROL HAZARD:

Do not exceed 20 mph (32km/h) when driving straight. Do not exceed 13 mph (21 km/h) in turns. The weight of the implement can cause under-steer, and the height of the implement is a tipping hazard.



LEVELING THE MACHINE

When initially setting the VertiSTRIP™ up to operate in the field the machine should be set level front to back and level left to right. To level center and wings refer to “Leveling the Implement” section on page 21.

In order to set front to back level of machine, pull into field, then lower implement in ground. Go a short distance while leaving the machine in the ground. Stop, put tractor into park. Then, adjust toolbar height so that bottom of the toolbar measures between 24-25” to the ground.

Once toolbar is set to proper operating height, adjust third-link on tractor until toolbar is level.

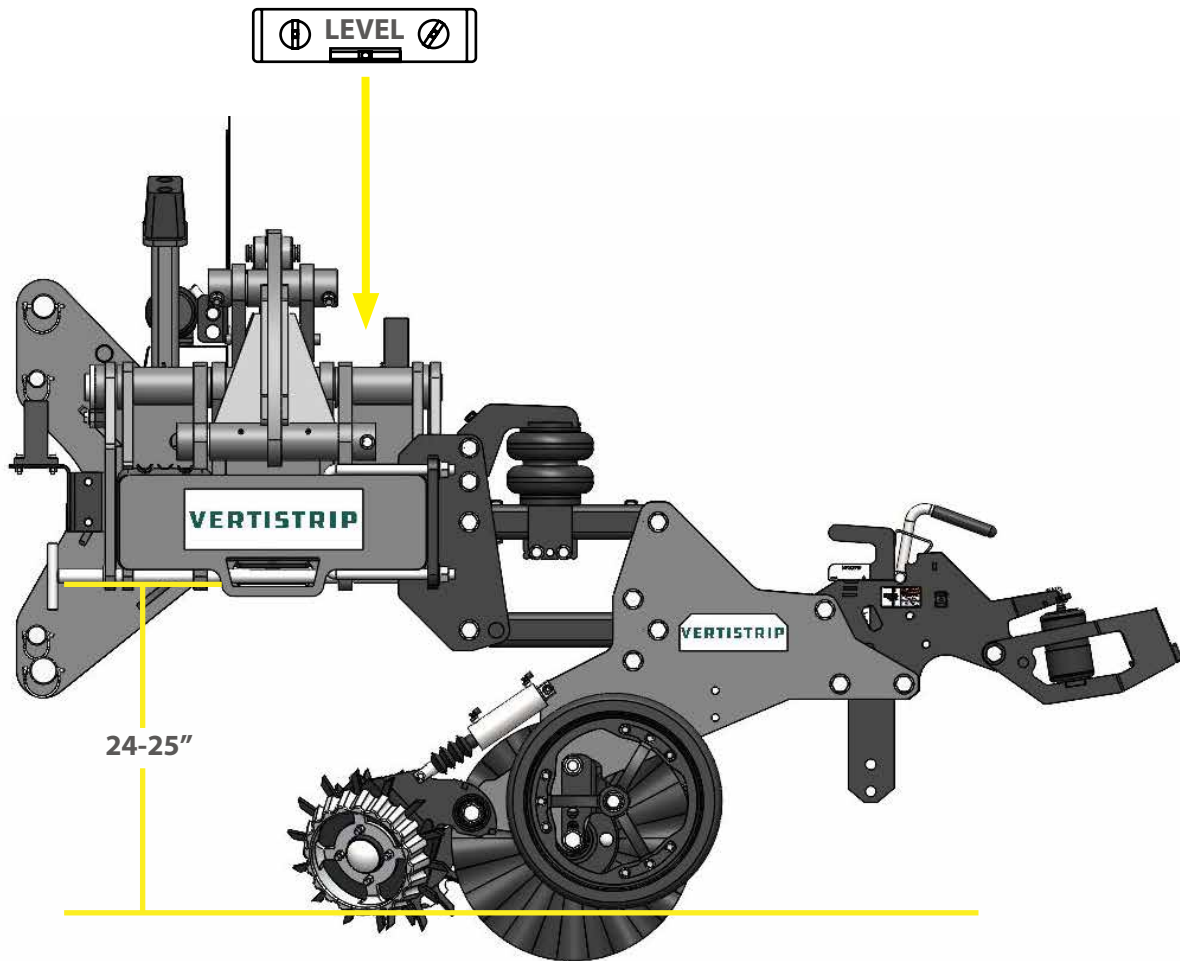



GAUGE WHEEL ADJUSTMENT

Gauge wheels are equipped with two different methods to adjust the depth of the gauge wheels. The first is to use the ratcheting turn buckle. To do this, loosen the jam nut with a combination wrench (1 ¾"). Then, turn the turn buckle to either lengthen or shorten the turn buckle. Then, re-tighten the jam nut.

The second method of adjustment is to change the lower position of the ratcheting turn buckle. The ratcheting turn buckle's standard location is in the center of the 3 holes on the lower arm and is the recommended setting for the VertiSTRIP™.

The gauge wheels are designed to help the tractor carry the machine through the field and hold proper depth.

NOTE: Gauge Wheels are optional accessories and do NOT come standard on VertiSTRIP™

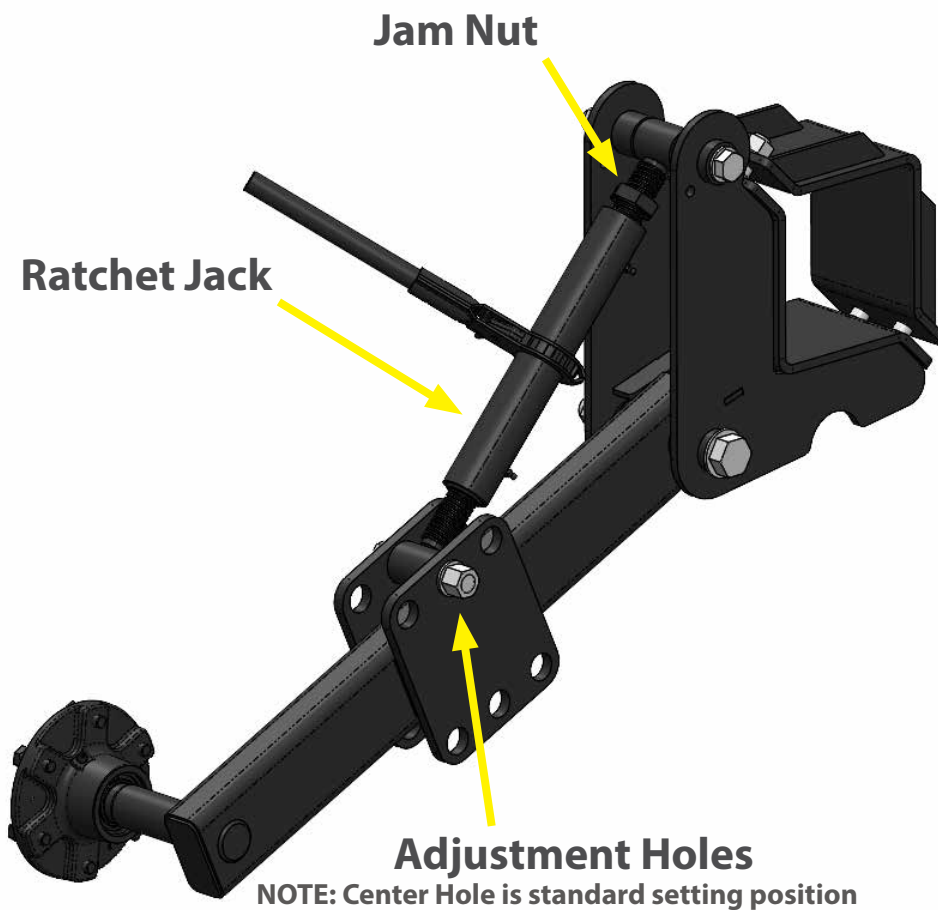



ROW UNIT AIR DOWNFORCE

AIR BAG OPERATION

It is recommended to start at 60 psi. The system can run at any pressure in the range of 0-120 psi. Increase or decrease the pressure to ensure the gauge wheels are touching the ground surface. The system is designed to keep the gauge wheels in contact with the ground at all times. If this is achieved the desired working depth of the knives & coulters will be correct.

- Starting pressure - 60 psi
- Increase if not reaching desired depth
- Decrease if being forced too deep
- Max air pressure 120 psi

To increase or decrease pressure adjust the air regulator on the air controller under the Row Unit Downpressure. Turn clockwise to increase pressure and counter clockwise to decrease.

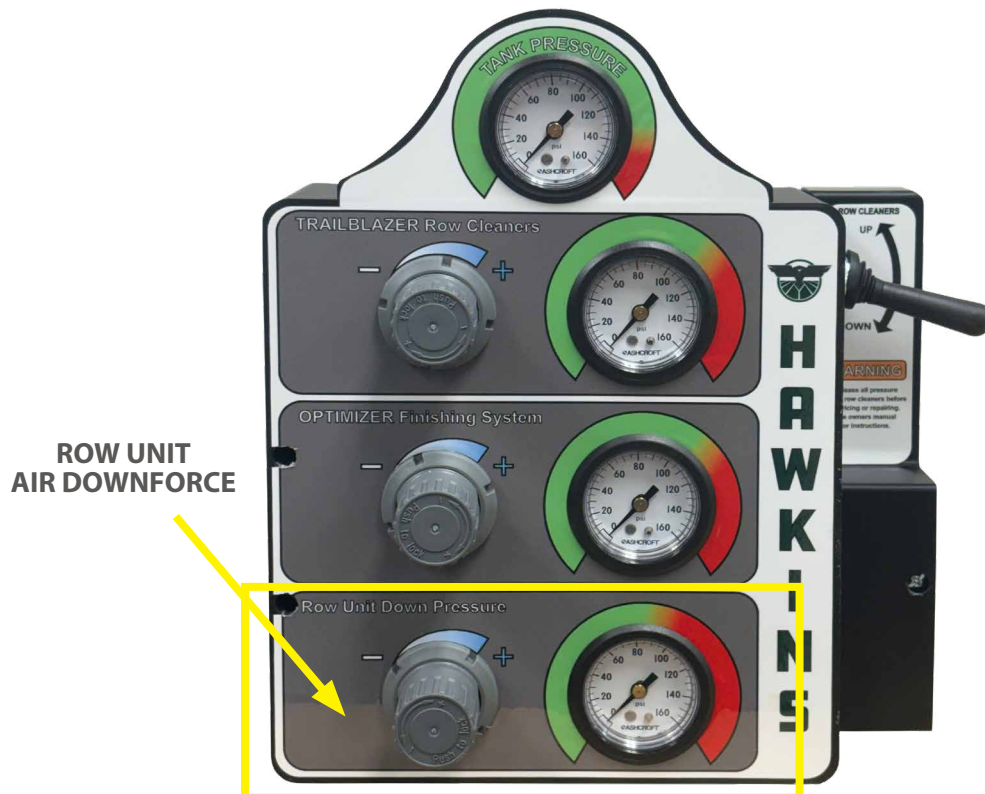



NOTE: This page is intentionally left blank.



NOTE: This page is intentionally left blank.



TRAILBLAZER™ ROW CLEANERS

The Trailblazer™ Row Cleaner is intended to run on the depth band and float along the top of the soil. There is an air cylinder that adjusts the pressure on the finger wheels.

The higher the pressure is set, the more aggressive the row cleaning will be. When there is no need to clear residue from the strip, the Trailblazer™ Row Cleaners can be disengaged by applying lift pressure to the air cylinder.

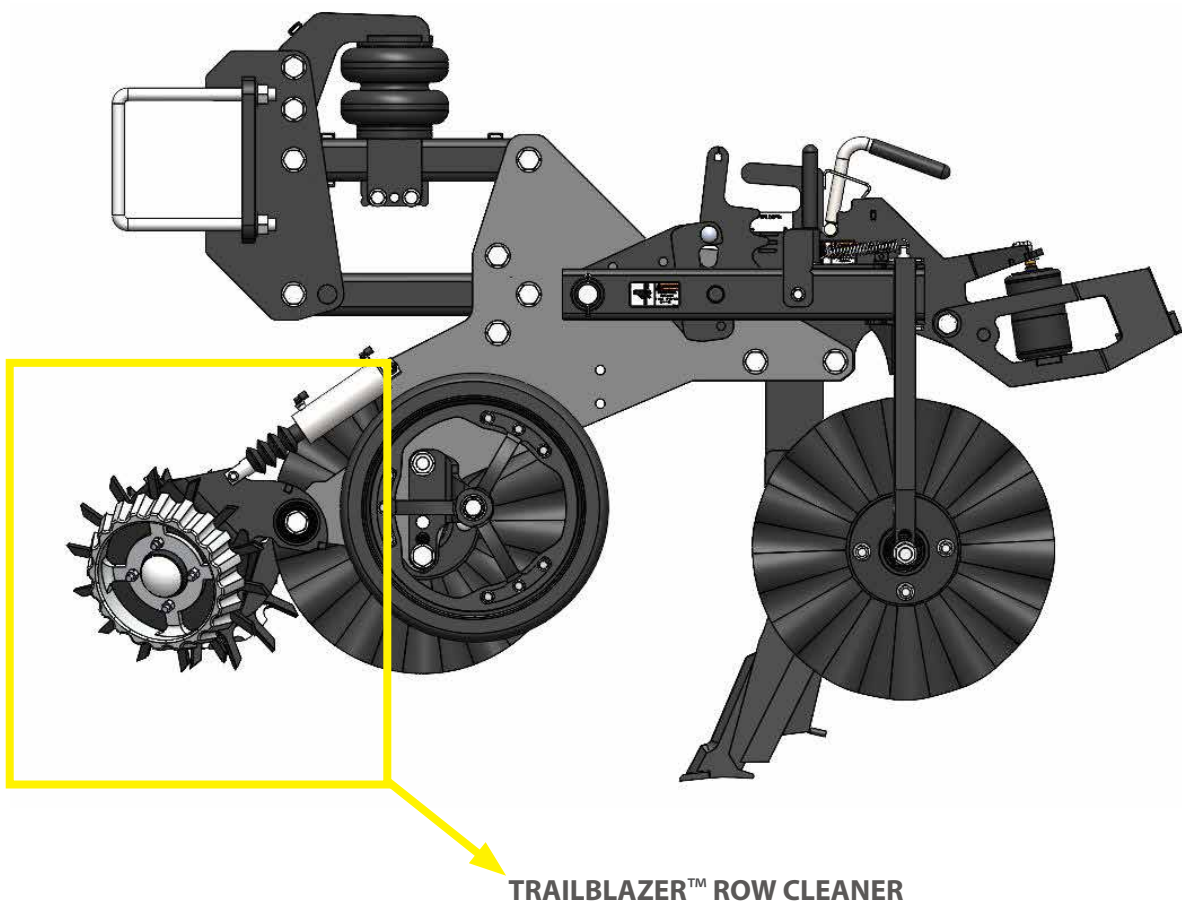



TRAILBLAZER™ ROW CLEANERS

DOWN FORCE ADJUSTMENT

Adjust the aggressiveness of cleaning or disengage the cleaners by adjusting the pressure in the air cylinders.

This is accomplished by turning the air regulator clockwise to increase air pressure and turning counter-clockwise to reduce pressure. The higher the pressure the higher the force on the row cleaner.

Recommended starting pressure is 40 psi down. Max pressure is 120 psi.

To raise Trailblazer™ Row Cleaners place switch to "UP". To lower Trailblazer™ Row Cleaner place switch to "DOWN".

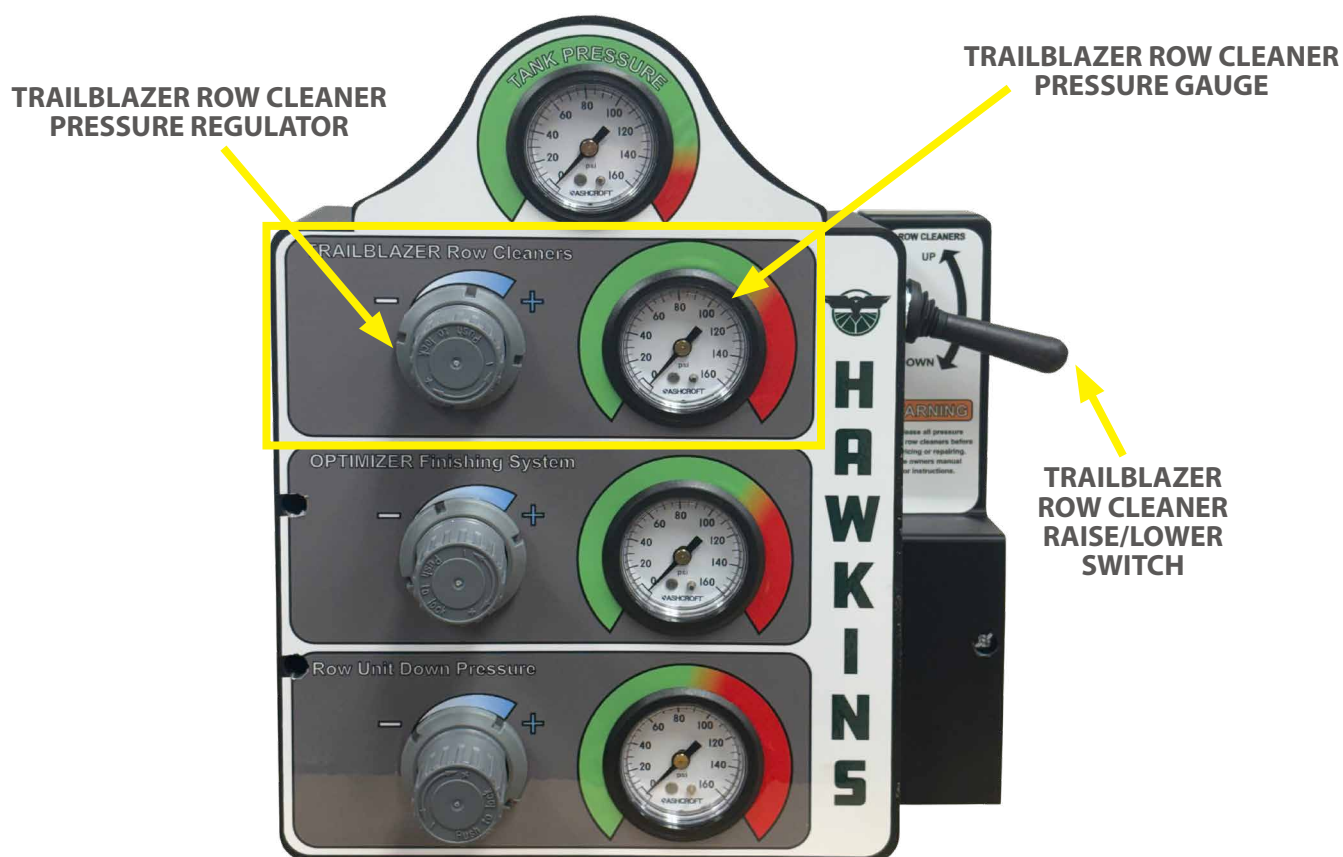



TRAILBLAZER™ ROW CLEANERS

BLADE POSITIONING

Offset Option: Factory setting. One Finger Blade is in the front hole while the other is set in the rear hole. This option allows the residue to not plug up the row cleaners. When choosing the offset option, we recommend half of the Trailblazer™ Row Cleaner have the Right Hand Finger Blade in the lead position and half of the Trailblazer™ Row Cleaners have the Left Hand Finger Blade in the lead position. When going across the machine it is recommended to alternate right hand lead and left hand lead. Left hand lead is shown below.

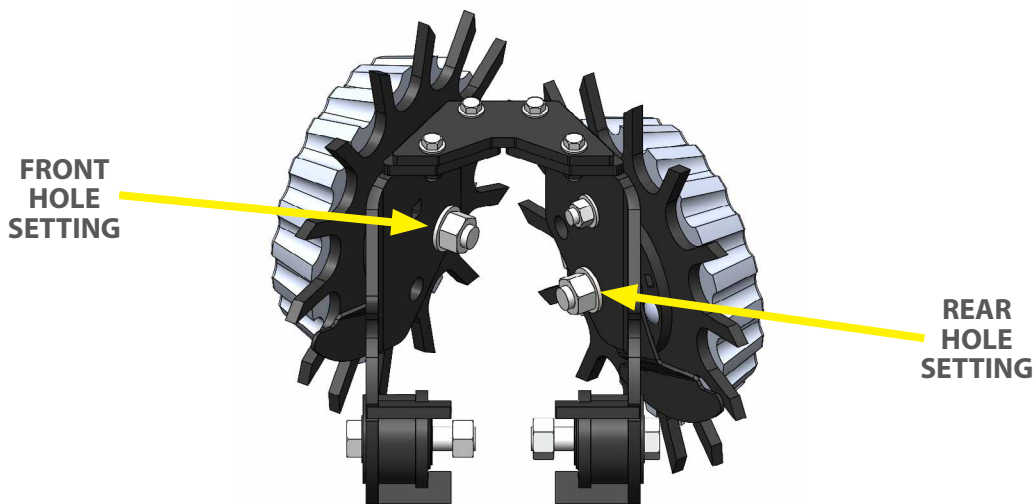

Meshed Option: Both finger blades set to the front holes. This is a more aggressive setting but is more likely to plug.

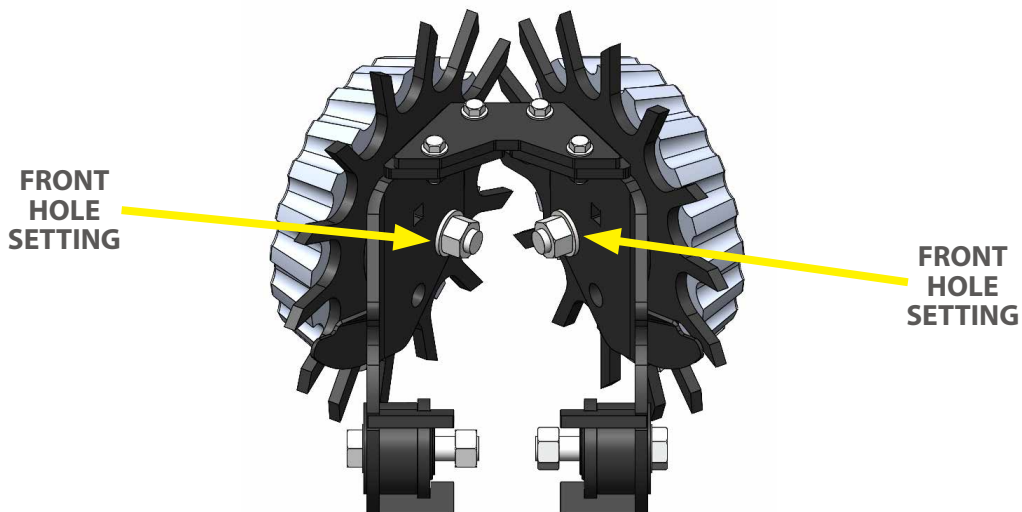



TRAILBLAZER™ ROW CLEANERS

SCRAPER POSITIONING

Your Trailblazer™ Row Cleaners come equipped with scrapers behind each blade to clear residue, such as root balls, from the blades as they travel through the field. The scrapers bolt on behind the blade hub in both the forward and rearward blade positions.

FORWARD SETTING

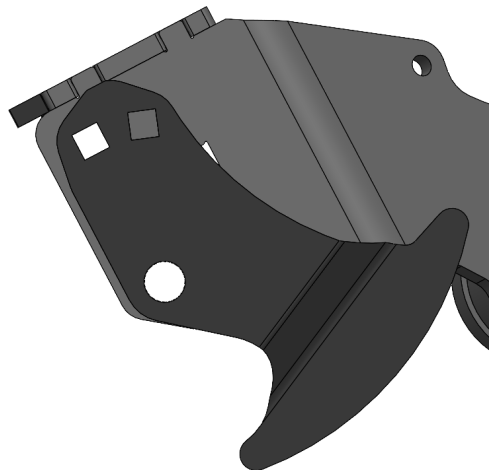

REARWARD SETTING

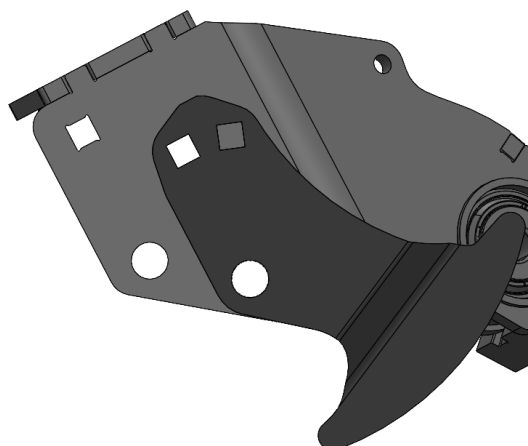



TRAILBLAZER™ ROW CLEANERS

SCRAPER CLOCKING

Your Trailblazer™ Row Cleaners scrapers are adjustable to accommodate a variety of field conditions. The factory clocking position uses the front square hole in the scraper. The rear square hole in the scrapers allows them to be set to clear residue later in the rotation of the blade. Factory setting is in the front. If Trailblazer™ Row Cleaners are plugging, try the rear hole setting to prevent this.

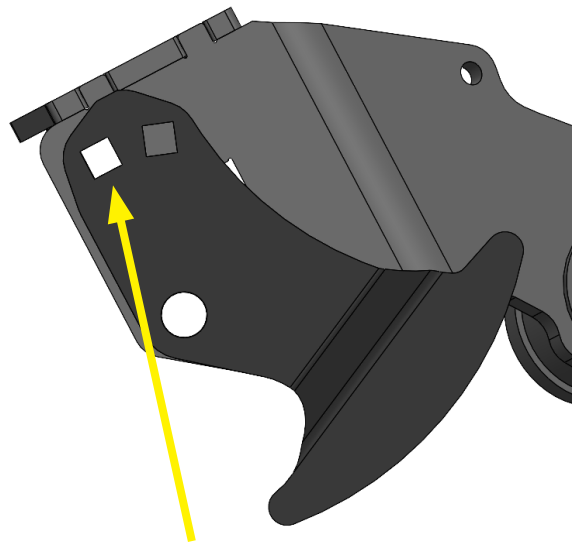

FRONT HOLE SETTING

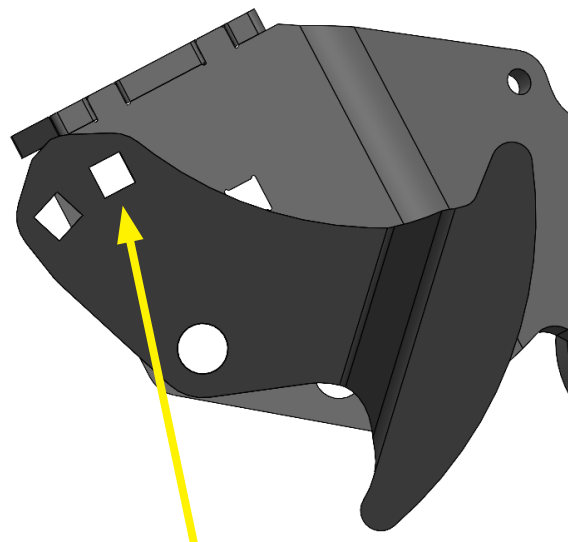

REAR HOLE SETTING



TRAILBLAZER™ ROW CLEANERS

SCRAPER POSITIONING

The scrapers on your Trailblazer™ Row Cleaners should be adjusted to lightly touch or clear the back of the blade by about $\frac{1}{32}$ " for ideal operation. If the scraper touches the blade with too much pressure, the blade may not rotate as designed, which could lead to plugging the unit. If the gap between the scraper and blade is too large, the scraper will not be as effective at removing residue from blade and may allow residue to build up and stop the blade from rotating. Scraper and finger blade share a bolt, make sure to install blade and scraper on same bolt.

A hammer and a punch can be used to adjust the gap by tapping on the scraper to slightly bend it in the desired direction. It is best to use the least amount of force required to adjust the scraper in the desired direction.

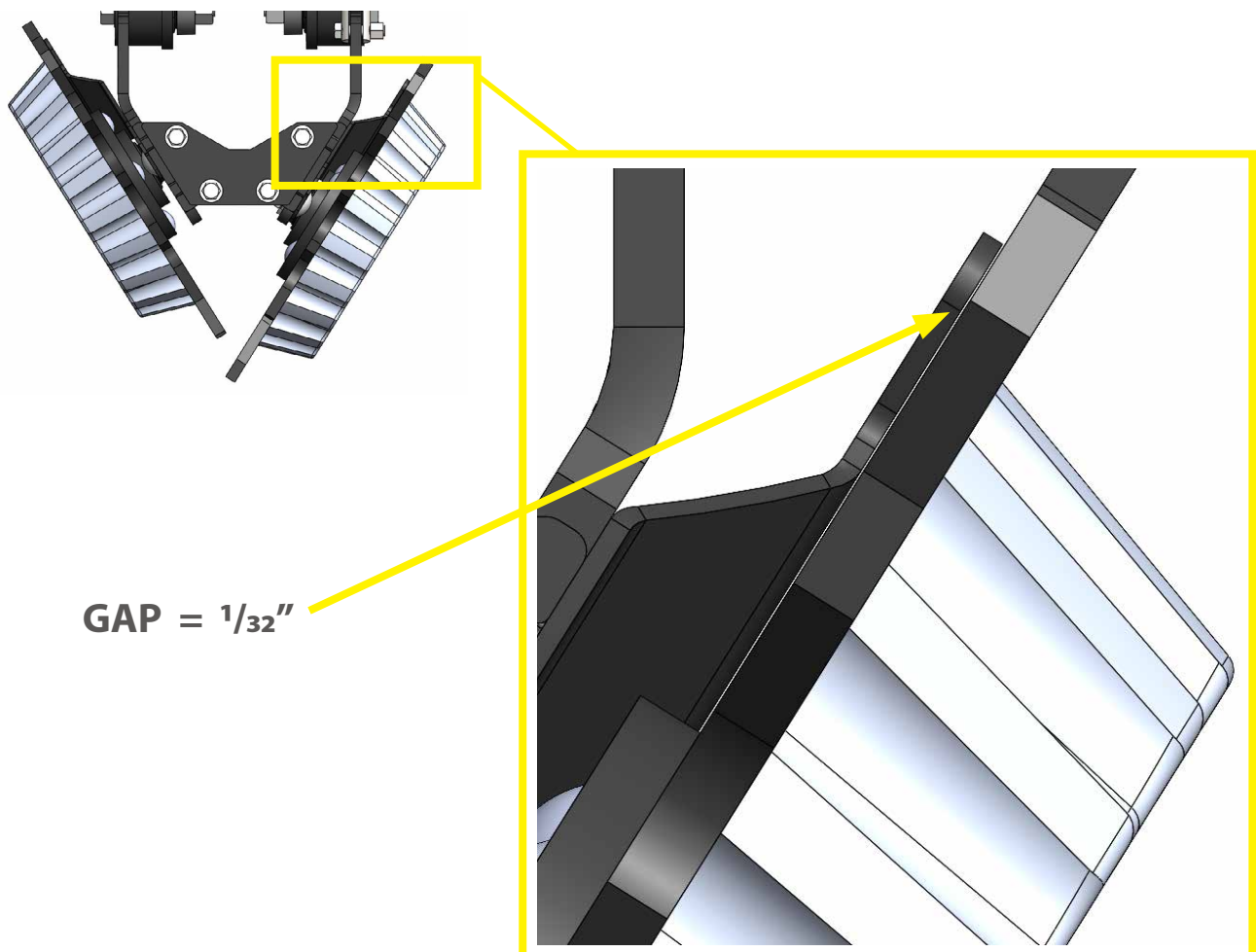



TRAILBLAZER™ ROW CLEANERS

BLADE ADJUSTMENT DO'S AND DON'TS

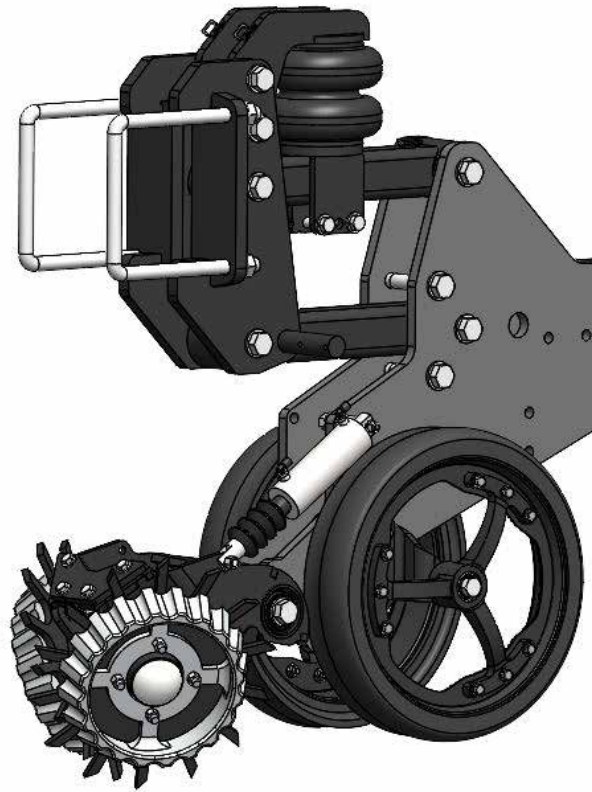

TRAILBLAZER™ ROW CLEANER DO'S AND DON'TS

- DO NOT operate at low speeds. Ground speed affects how effective the Trailblazer™ Row Cleaners can manage residue; we recommend operating at 4+ mph to maintain good residue flow.
- DO NOT expect crop residue to be completely cleared. Ground conditions, residue conditions, and ground speed can affect the effectiveness of the Trailblazer™ Row Cleaners.
- DO work to regularly maintain your Trailblazer™ Row Cleaners. Keep clean and free of debris, check that bearings move freely and smoothly, and hardware is tight and in good condition.
- With proper care, you can expect a longer and more effective lifespan for your Hawkins Ag equipment.

It is recommended to leave the blades in the offset setting. The best adjustment to make is with air pressure. The greater the down air pressure the more aggressive the cleaning will be.



FRONT COULTER DEPTH ADJUSTMENT

The depth of the front coulters can be adjusted by changing the hole position in the row unit. The factory setting is the bottom hole. This applies to knife machines as well.

To adjust depth, remove the $\frac{3}{4}$ " bolt holding the coulters on using a $1\frac{1}{8}$ " wrench and socket with impact.

Bolt can be reached without removing gauge wheel.

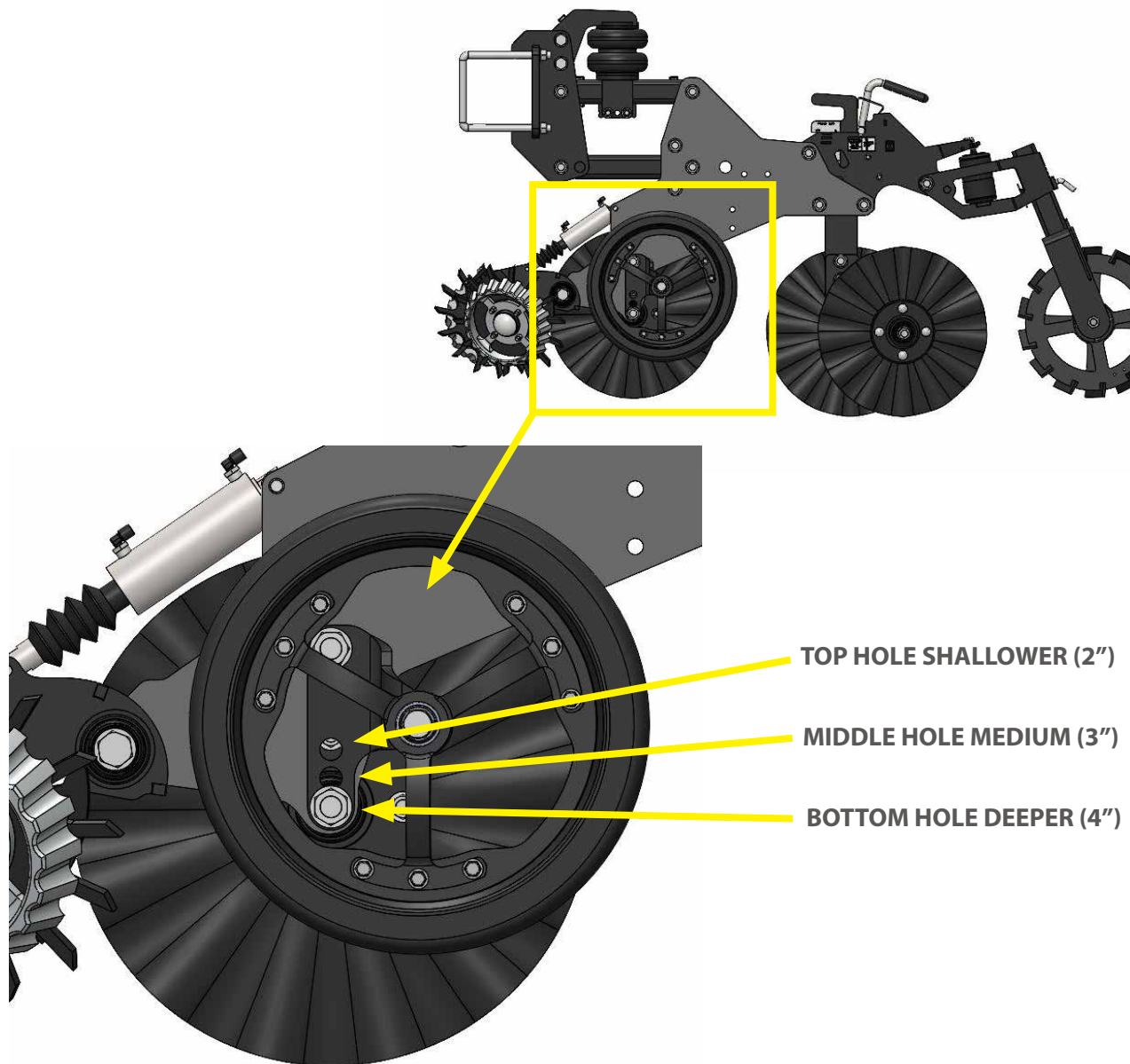



OPTIMIZER™ FINISHING SYSTEM

VertiSTRIP™ can be outfitted with 2 different Optimizer finishing systems: Basket and Steel Wheels.

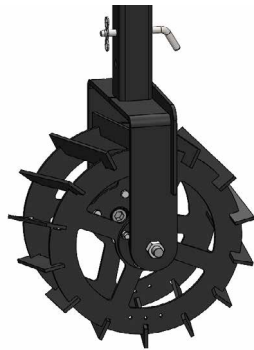

BASKET



STEEL WHEELS

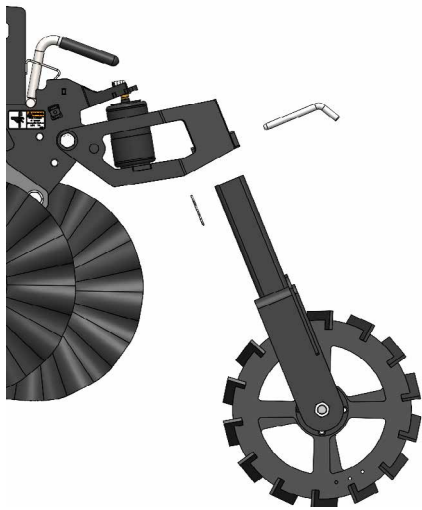

Each Optimizer finishing system can be added / removed / exchanged by removing the 1/2" pin and retainer.

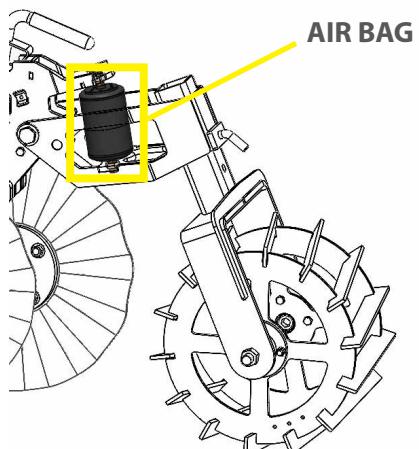

Down pressure is applied by the air bag on the rear of the row unit.



OPTIMIZER™ FINISHING SYSTEM

AIR BAG OPERATION

It is recommended to start at 60 psi. The Optimizer™ Finishing System can run at any pressure in the range of 0-120 psi. Increase or decrease the pressure to get the conditioning that is desired. The basket is expected to condition the soil into a firm strip. If large clods are still present after the basket has run, increase air pressure to help reduce their size. If a divot is made where the basket ran, reduce air pressure to improve the quality of the strip.

- Starting pressure - 60 psi
- Increase if more firming action is required.
- Decrease if ground is becoming overly compressed.
- Max air pressure 120 psi

To increase or decrease pressure adjust the air regulator on the air controller under the Optimizer™ finishing system. Turn clockwise to increase pressure and counter clockwise to decrease.

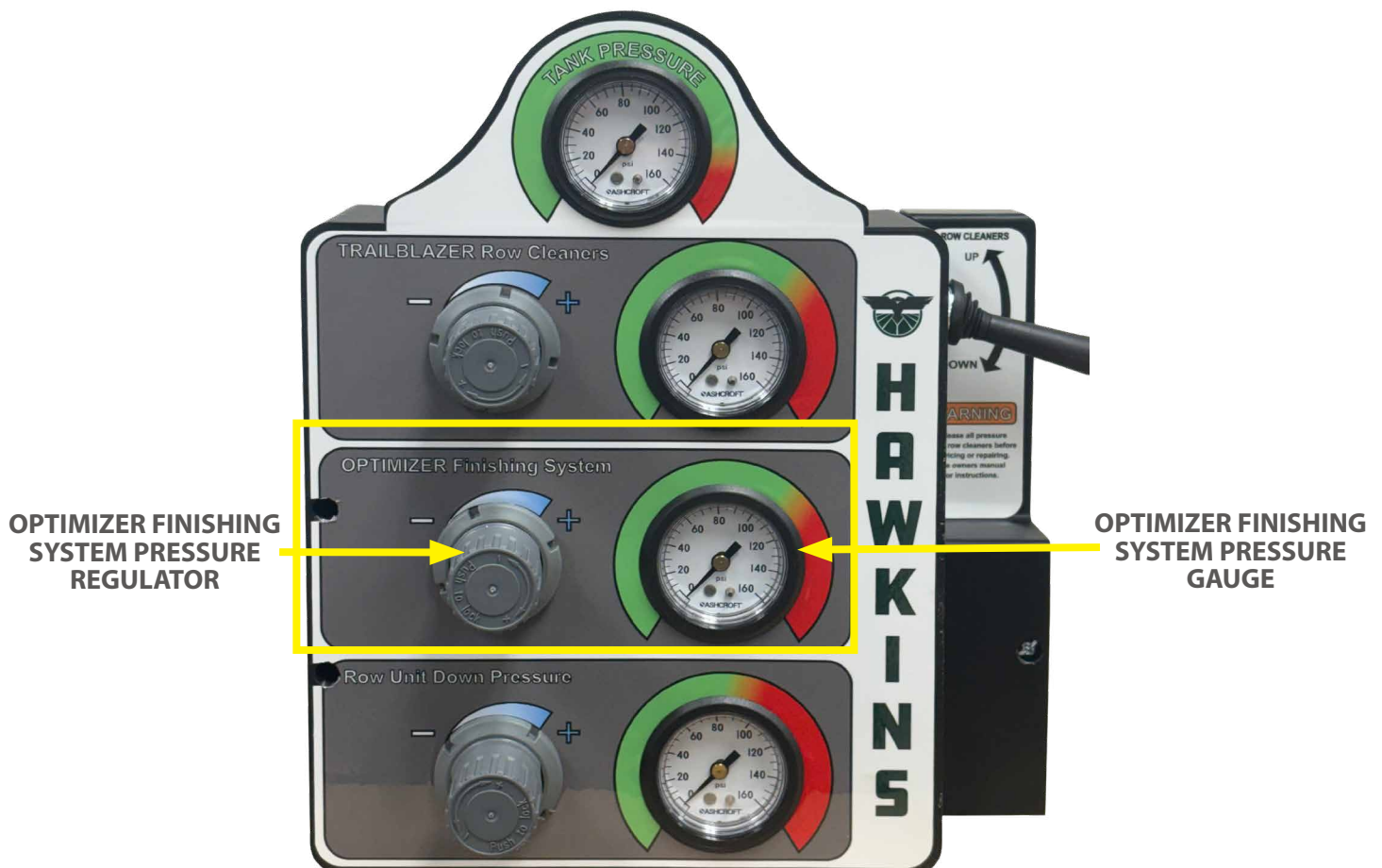



OPTIMIZER™ FINISHING SYSTEM

OPTIMIZER FINISHING SYSTEM™ DO'S AND DON'TS

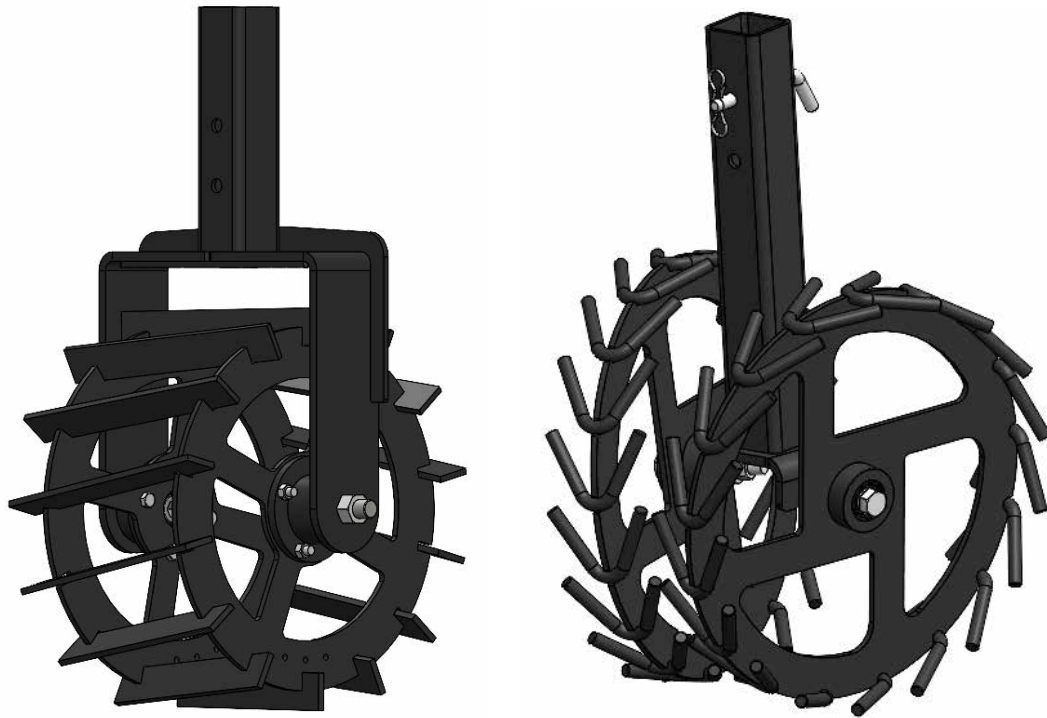

- DO NOT run air pressure greater than 120 PSI - the system is rated for a maximum of 120 PSI.
- DO NOT operate at low speeds. The Optimizer™ Finishing System was designed for speeds greater than 4 mph. Speeds below 4 mph will not yield optimum strip conditioning.
- DO keep Optimizer™ Finishing System free of debris and excessive mud buildup.
- DO work to regularly maintain your Optimizer™ Finishing System. With proper care, you can expect a longer and more effective lifespan for all of your Hawkins equipment.
- DO check that the finishing system rotates freely before each use. Failure to do so may decrease effectiveness and cause damage to the finishing system. If bearings seize or make excessive noise during operation, replace bearings.



ROW CONFIGURATIONS

VertiSTRIP™ row units are set up from the factory in left-hand and right hand configurations based on which side of the Trailblazer™ row cleaner and offset coulters lead and trail blade.

Row units alternate left and right to allow residue to flow between the units.

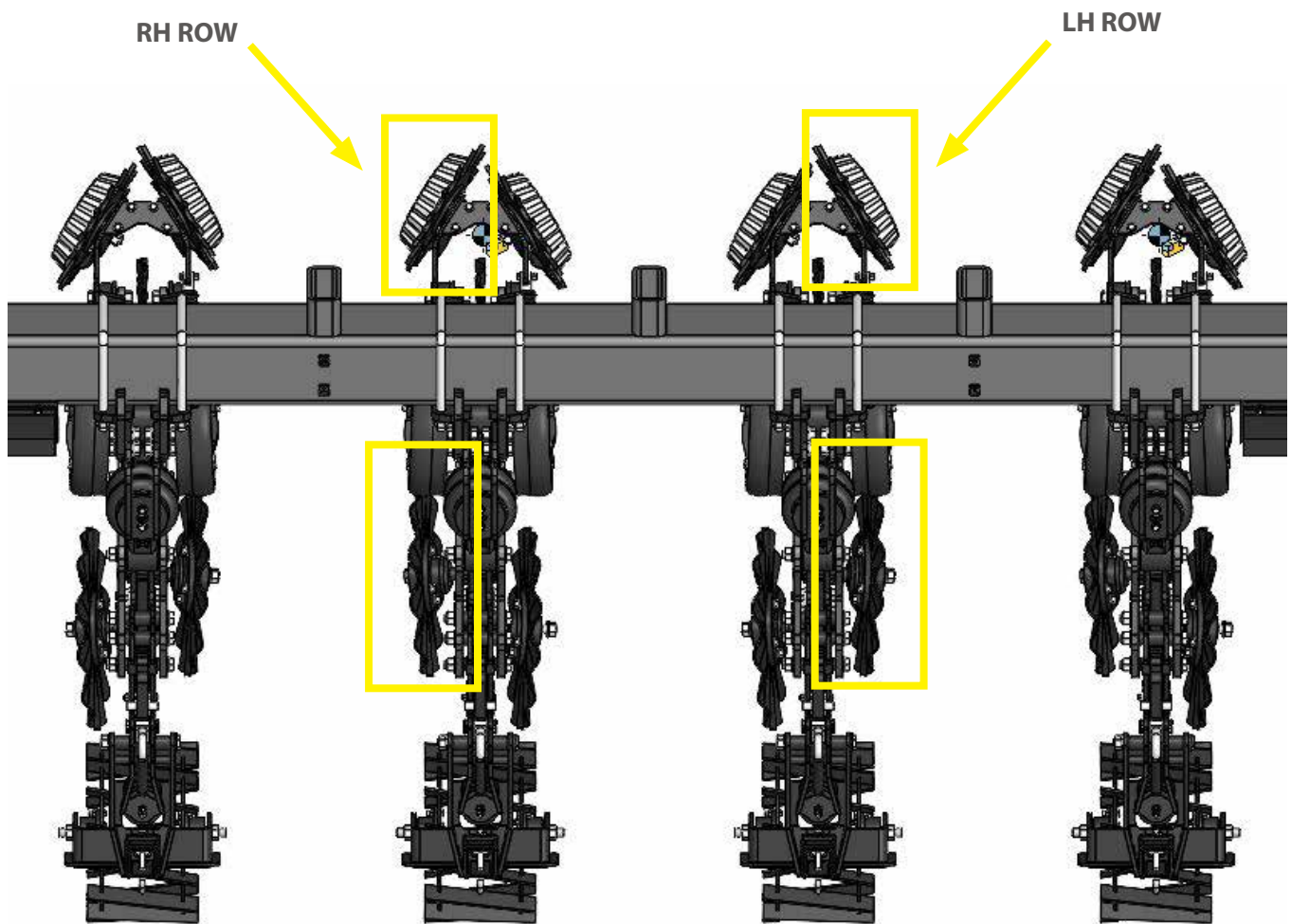

OPERATION



COULTER MACHINE

VertiSTRIP™ is designed to run the rear coulters at a depth of 2" to 6". Front coulters can run at 2" deep in the top hole, 3" deep in the middle hole or 4" deep in bottom hole.

We make no recommendations for products, placement, or timing of fertilizer applications. Refer to your agronomist for products, placement, depth, and timing for fertilizer application that fit your operation.

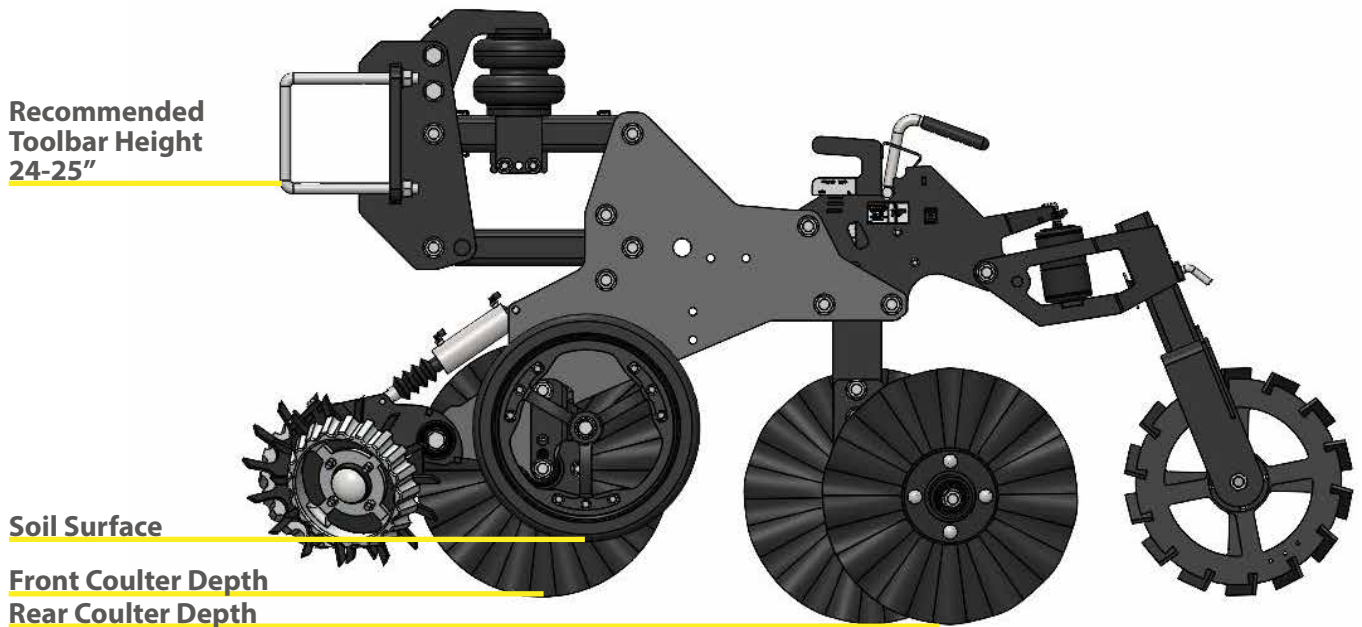



REAR COULTER ADJUSTMENT

Rear coultter or knife adjustment is controlled by adjusting the rear shank up and down. The shank is locked in place by a simple wedge lock mechanism. The locked and adjustable position are shown below. When adjusting the shank, the machine needs to be lifted with no pressure on the included knives. The left hand side of the shank decal shows the knife depth and the right hand side shows the coultter depth.

Adjustment Handle Engaged

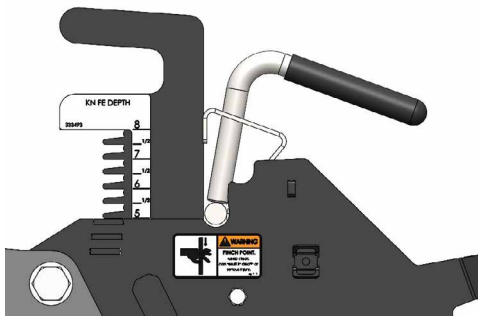

Adjustment Handle Disengaged

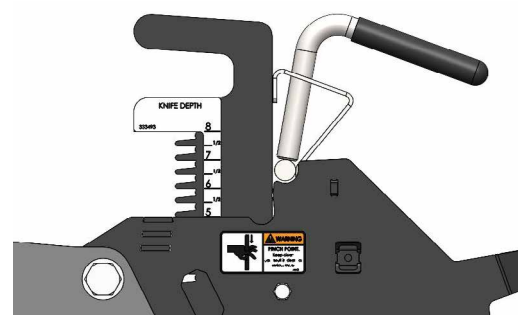

SHANK RETAINER HANDLE

1. Locate Shank Retaining Handle and Shank Handle

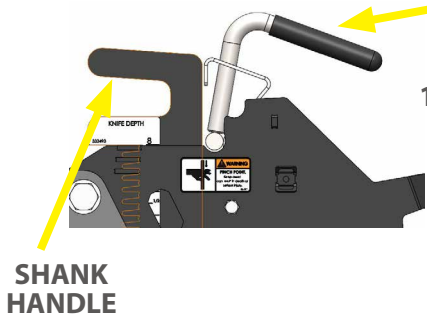

SHANK HANDLE

2. Pull up and back on the shank retainer handle, seat in retainer position

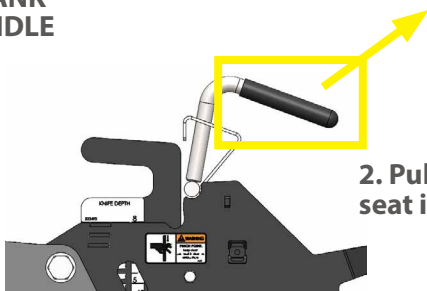

3. Pull back on the shank handle to disengage teeth

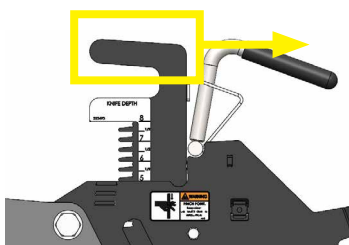



REAR COULTER ADJUSTMENT

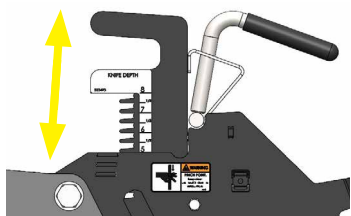

4. Raise/lower shank to place coulters at desired position

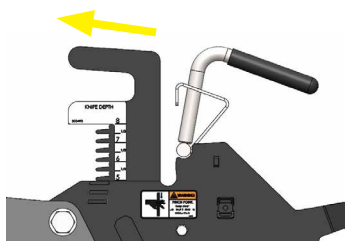

5. Push shank forward to reengage teeth

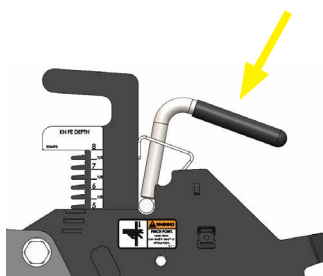

6. Rock shank adjustment handle back to disengage it from retainer position and drop back into operating position

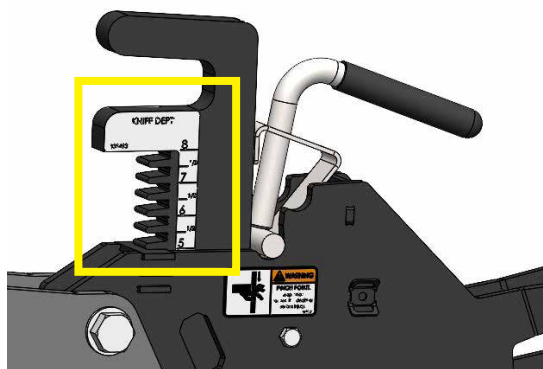

THE LEFT HAND SIDE OF THE SHANK DECAL SHOWS THE KNIFE DEPTH AND THE RIGHT HAND SIDE SHOWS THE COULTER DEPTH.



KNIFE MACHINE

VertiSTRIP™ is designed to run the rear coulters at a depth of 2" to 6". Front coulters can run at 2" deep in the top hole, 3" deep in the middle hole or 4" deep in bottom hole.

We make no recommendations for products, placement, or timing of fertilizer applications. Refer to your agronomist for products, placement, depth, and timing for fertilizer application that fit your operation.

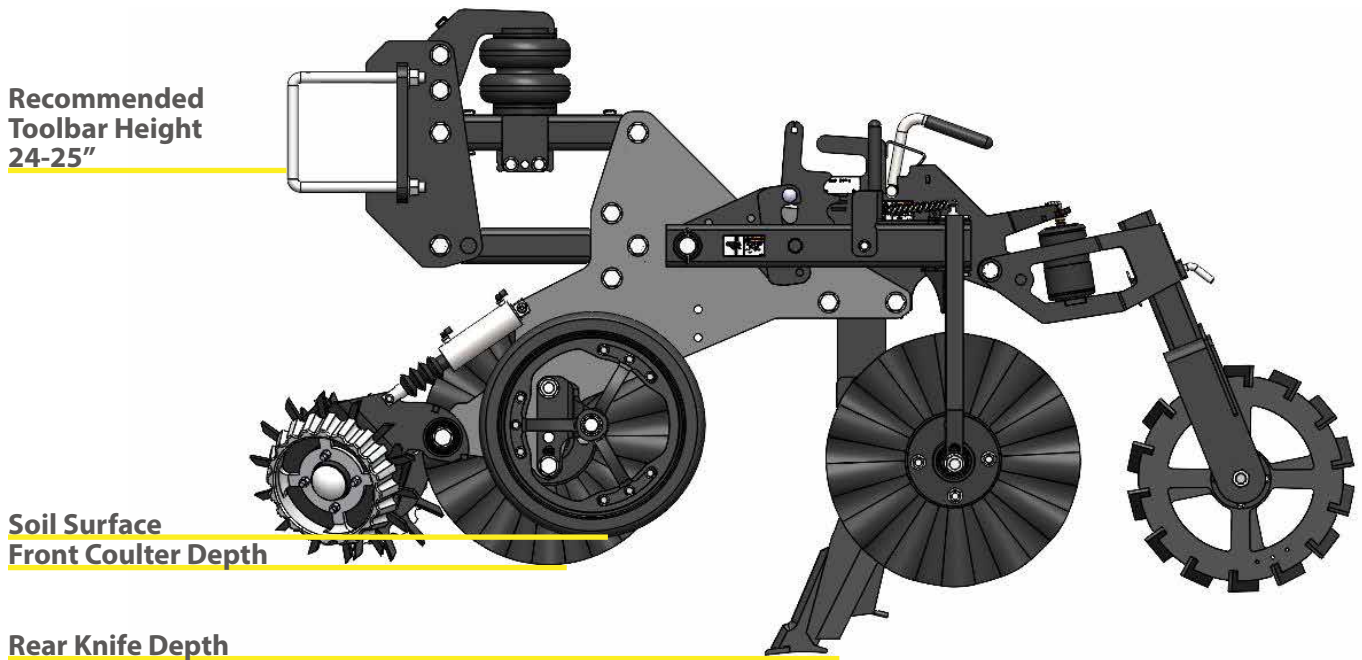



REAR KNIFE ADJUSTMENT

Rear coultter or knife adjustment is controlled by adjusting the rear shank up and down. The shank is locked in place by a simple wedge lock mechanism. The locked and adjustable position are shown below. When adjusting the shank, the machine needs to be lifted with no pressure on the rear knife.

Adjustment Handle Engaged

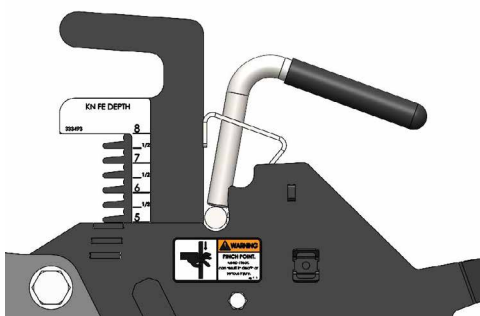

Adjustment Handle Disengaged

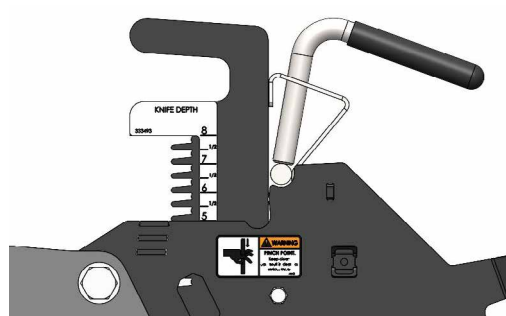

SHANK RETAINER HANDLE

1. Locate Shank Retaining Handle and Shank Handle

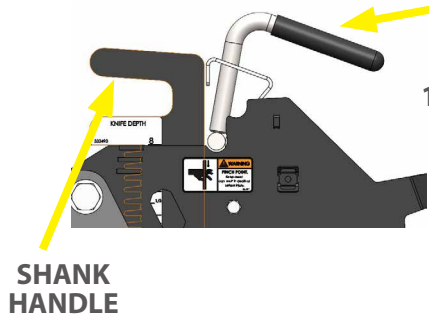

2. Pull up and back on the shank retainer handle, seat in retainer position

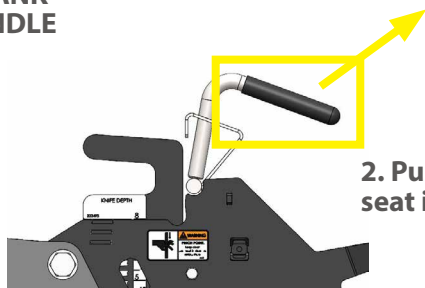

3. Pull back on the shank handle to disengage teeth

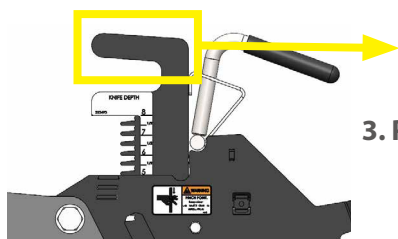



REAR KNIFE ADJUSTMENT

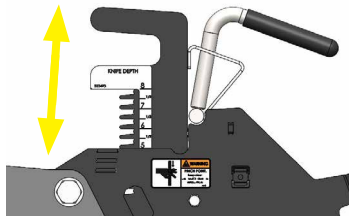

4. Raise/lower shank to place coulters at desired position

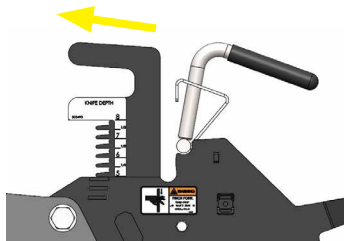

5. Push shank forward to reengage teeth

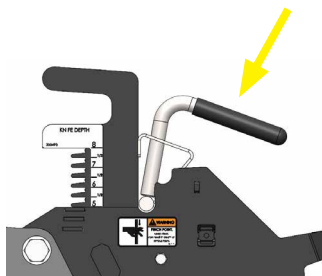

6. Rock shank adjustment handle back to disengage it from retainer position and drop back into operating position

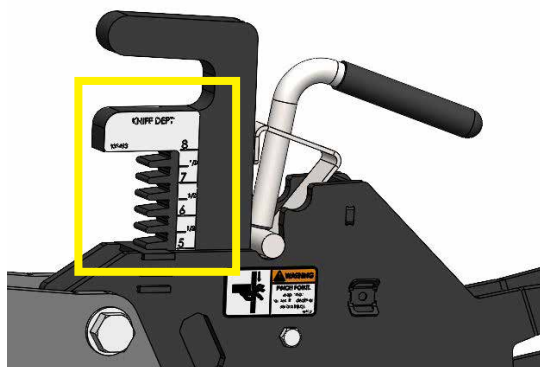

THE LEFT HAND SIDE OF THE SHANK DECAL SHOWS THE KNIFE DEPTH AND THE RIGHT HAND SIDE SHOWS THE COULTER DEPTH.



FLEXBERM™

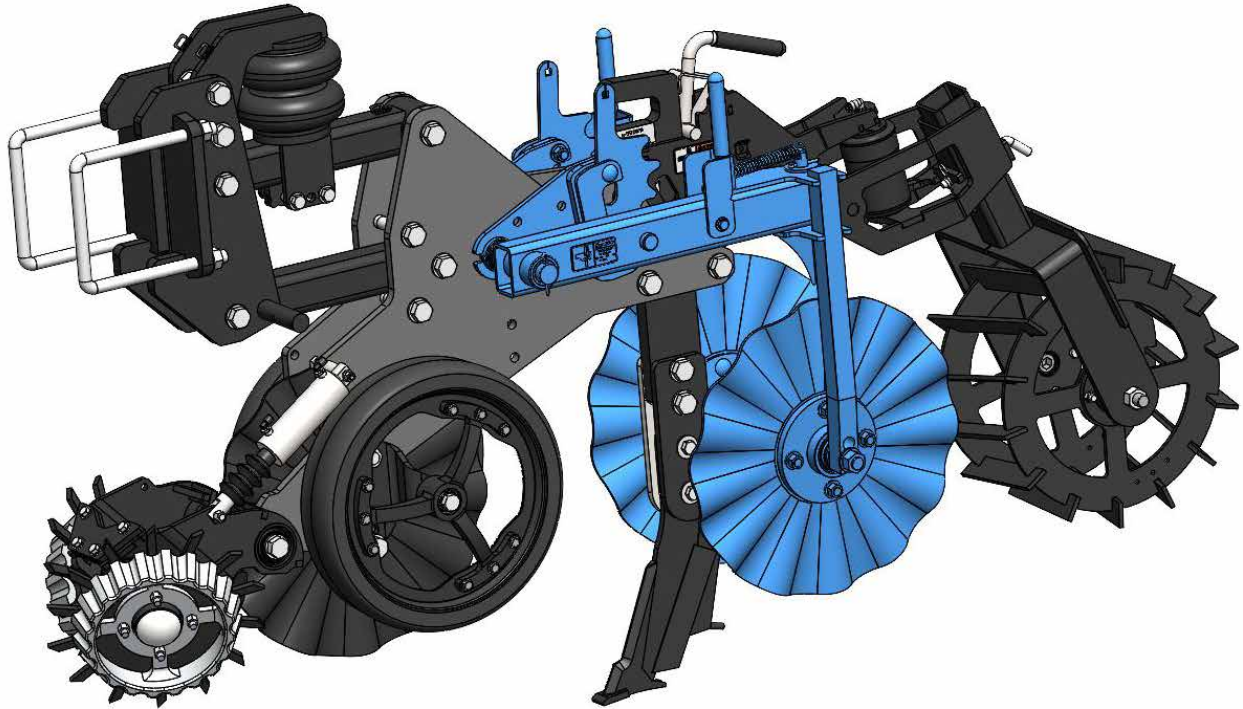

The FlexberM™ comes standard on all knife machines. It is designed to create a berm around the area where the knife runs. There are three main adjustments to achieve the desired results: Blade Depth, Blade Angle, and Blade Width.



FLEXBERM™ Adjust Blade Depth

The FlexBerm has three (3) different options of depth stop settings. By rotating the handle, you are able to choose your minimum depth stop setting. (Views below have a section cut out to show depth settings clearly).

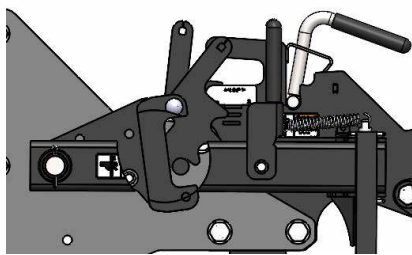

Depth Stop Setting 1
(3 ¾")

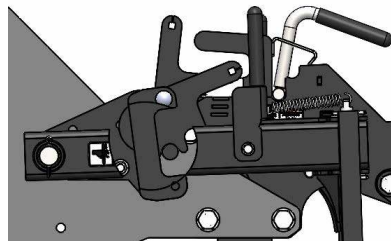

Depth Stop Setting 2
(3")

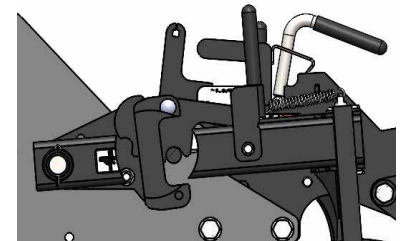

Depth Stop Setting 3
(2")

Lock FlexBerm Up

You can also lock the FlexBerm up by rotating the handle out of the way. Lift the arm assembly up and rotate to hold the FlexBerm up as shown below.

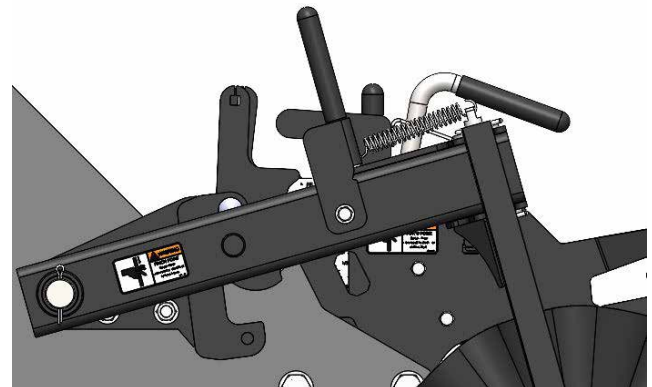
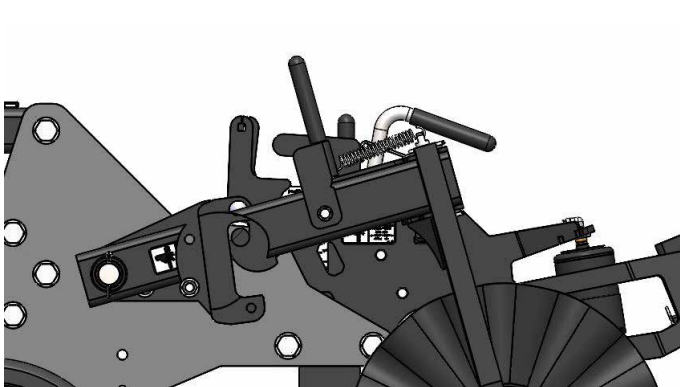



FLEXBERM™

Adjust Blade Angle

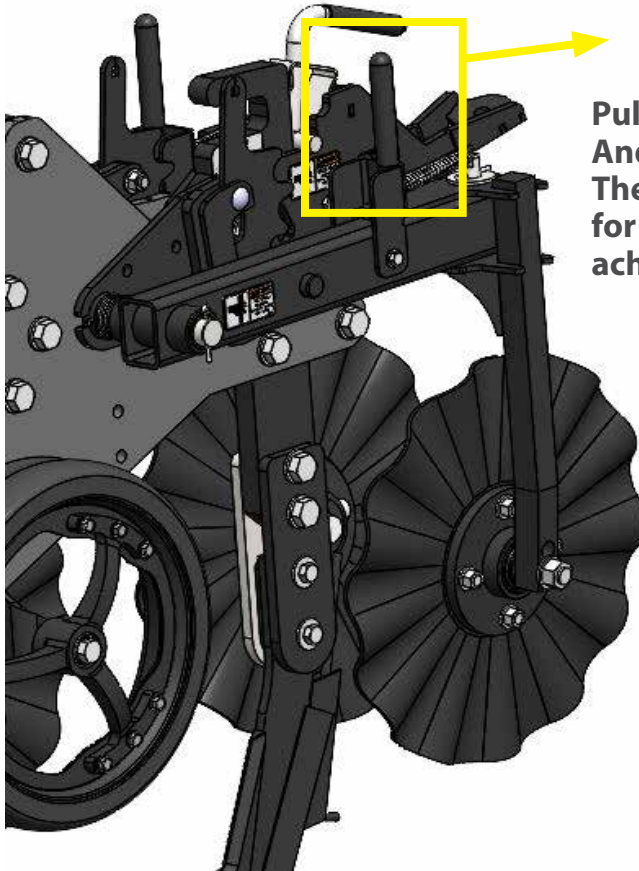

Pull handle back in direction shown
And rotate blades as shown.
The blade angles can be adjusted to allow
for more aggressive berm building if not
achieving the desired berm.

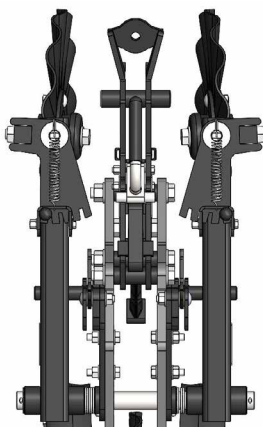

Rotate Position 1

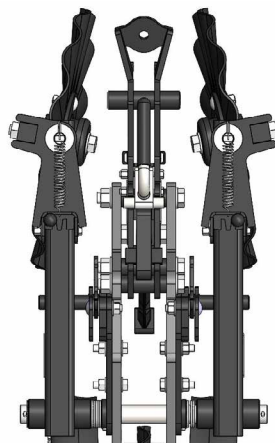

Rotate Position 2

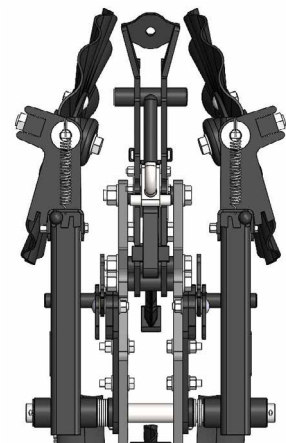

Rotate Position 3



FLEXBERM™

Adjust Blade Width

The Flexberm blade width can be adjusted by removing and relocating washers located on the mount pin for each side.

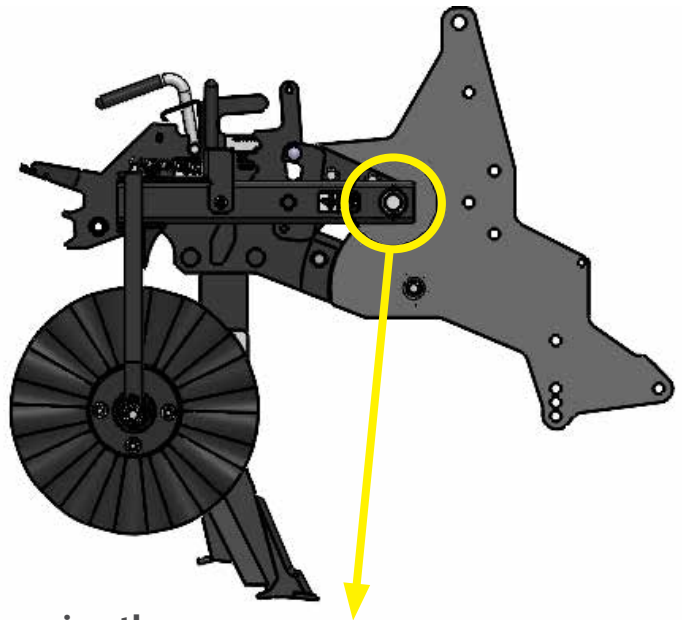

Start by removing the cotter pin shown here

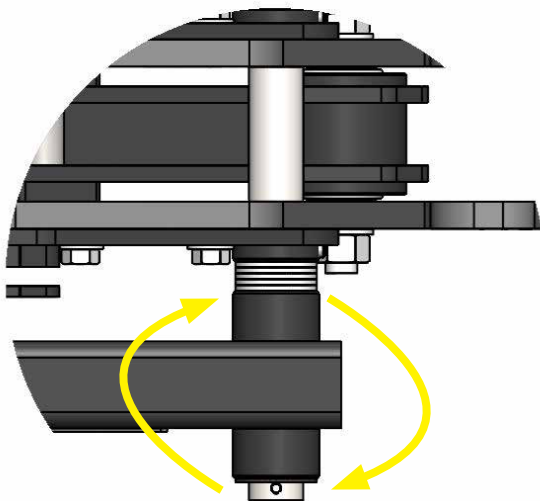
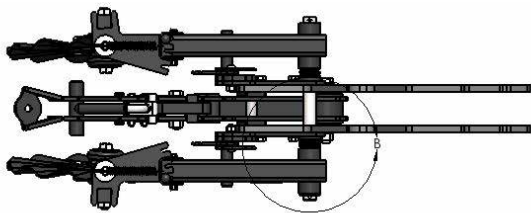
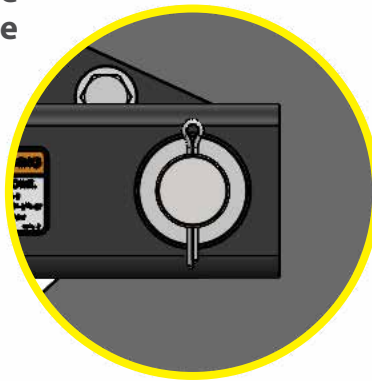

Washers can then be swapped on either side of the arm to increase or decrease width of the blades. For narrow rows, start with one washer on the inside.



FLEXBERM DO'S AND DON'TS

- DO NOT operate at low speeds. Ground speed affects how effective FlexBerm™ can build berms; we recommend operating at 5+ mph to build berms.
- DO NOT expect desired berms at the manufacturer's default settings. Ground conditions, residue conditions, and ground speed can affect the effectiveness of FlexBerm™
- DO work to regularly maintain your FlexBerm™ row units. Keep clean and free of debris, check that bearings move freely and smoothly, and hardware is tight and in good condition. With proper care, you can expect a longer and more effective lifespan for your Hawkins Ag equipment.



HYDRAULIC TRIPPING SYSTEM

The hydraulic tripping system uses a pressure relief valve with constant flow from the tractor to allow the knife plate to trip when encountering a hard object in the soil and reset itself automatically. The resistance to tripping is controlled by the hydraulic system pressure and can be set between 500 and 2500 psi (see page 59 for more details).

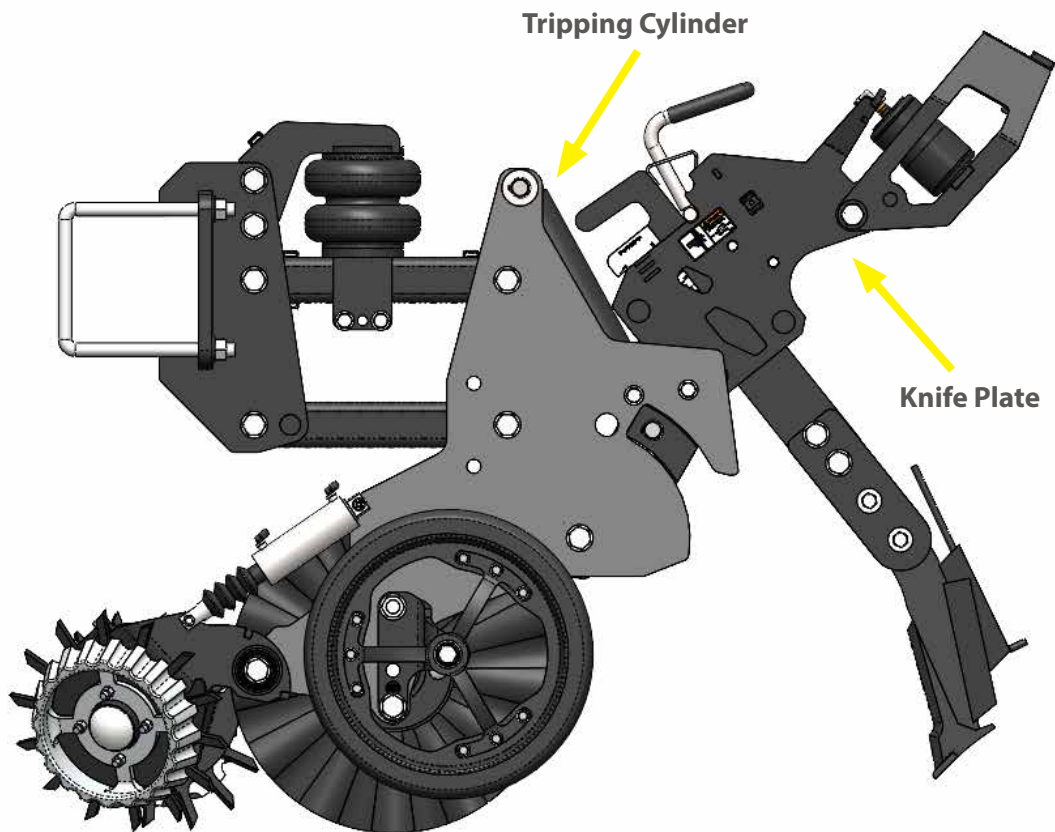

Tripping Hydraulic Block

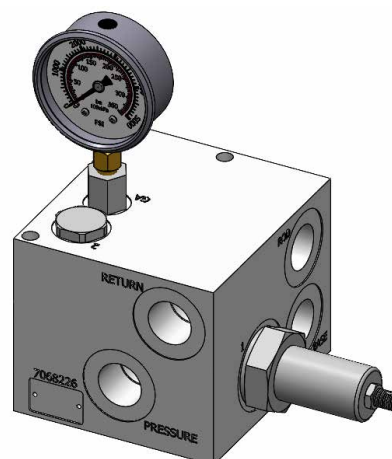

Pressure Relief Adjustment Screw



HYDRAULIC TRIPPING SYSTEM

CONNECTING

- Connect the hose from the pressure port on the hydraulic block to the pressure-side SCV port on your tractor.
- Connect the hose from the return port on the hydraulic block to the corresponding return SCV port on your tractor.
- Set the hydraulic SCV connected to the tripping system hoses to run in the constant flow function.
- Set the hydraulic flow of the SCV to 1 to 2 gallons per minute.
- Prepare to check the function of the hydraulic system by making sure all people, animals, and obstructions are clear from the machine.
- Cycle the system through the travel range of the cylinders and check that all rows function as expected.
- Always place the system in “float” when performing work on the row units.
- Pressurize the system and check that the gauge indicates the desired pressure. If not, adjust pressure screw.
- Once you have performed a check and set the system pressure to a starting point of 1800 PSI, the machine is ready to go to the field.

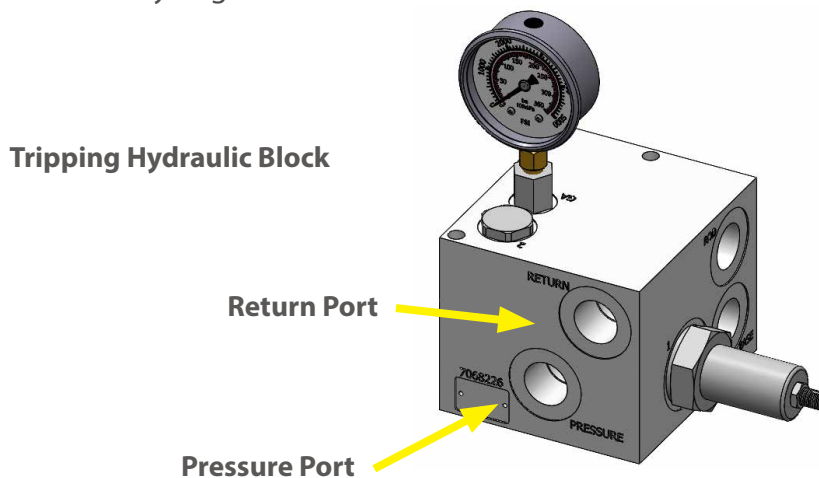

HIGH PRESSURE FLUID - DANGER

Use safe practices. Fluid injection can occur; will result in death or serious injury. Hazards may include, but are not limited to, injury beyond the entry point, over pressurized components, damaged components, components with excessive wear, swollen components, ect.



HYDRAULIC TRIPPING SYSTEM

SETTING PRESSURE

- The tripping force can be adjusted by adjusting system pressure on the hydraulic block.
- Pressure can be adjusted from 500 to 2500psi.
- To increase system pressure (more resistance to tripping) turn the adjustment screw on the hydraulic block clockwise.
- To decrease system pressure (less resistance to tripping) turn the adjustment screw on the hydraulic block counter-clockwise.
- Typically, it is best to set the system to the lowest pressure that keeps the knives in the ground but allows the units to trip when encountering an obstruction. Lower pressures will prolong the life of the system and reduce knife breakage.
- When setting your hydraulic tripping system start at 1800 PSI and work up or down depending on your specific soil conditions and needs. **Refer to the chart below for recommended pressure adjustment increments as you get started.**
- Make fine adjustments as you start to find a pressure range that keeps the knives engaged in obstruction-free soil.

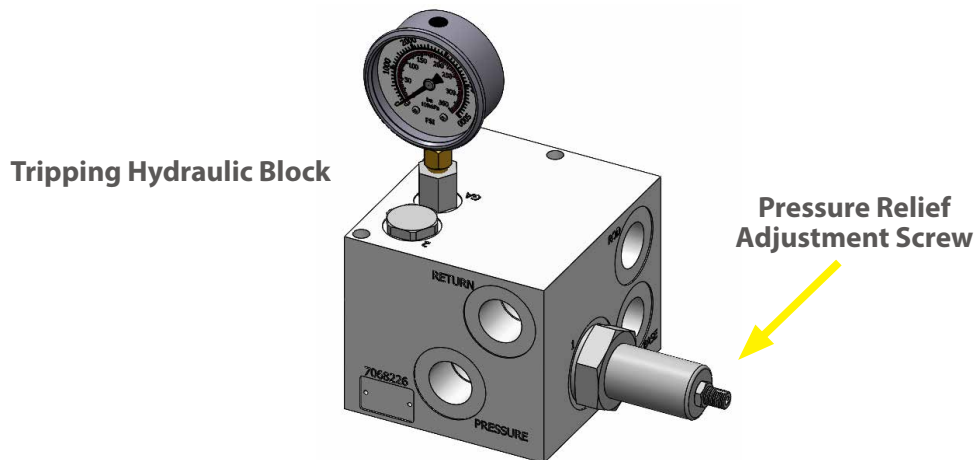

Pressure (PSI)	Increments of Adjustment
500-1000 PSI	250 PSI
1000-1500 PSI	100 PSI
1500-2000 PSI	50 PSI
2000+ PSI	25 PSI



DUAL PLACEMENT LIQUID

- The VertiSTRIP™ can be equipped with a dual placement liquid fertilizer behind the coulters.
- The dual liquid coulters come standard with a 1/4 NPT male x 3/8 Hose barb (standard) can be converted to a quick connect fitting.
- Will accept a spray nozzle with 1/4 NPT Male threads.

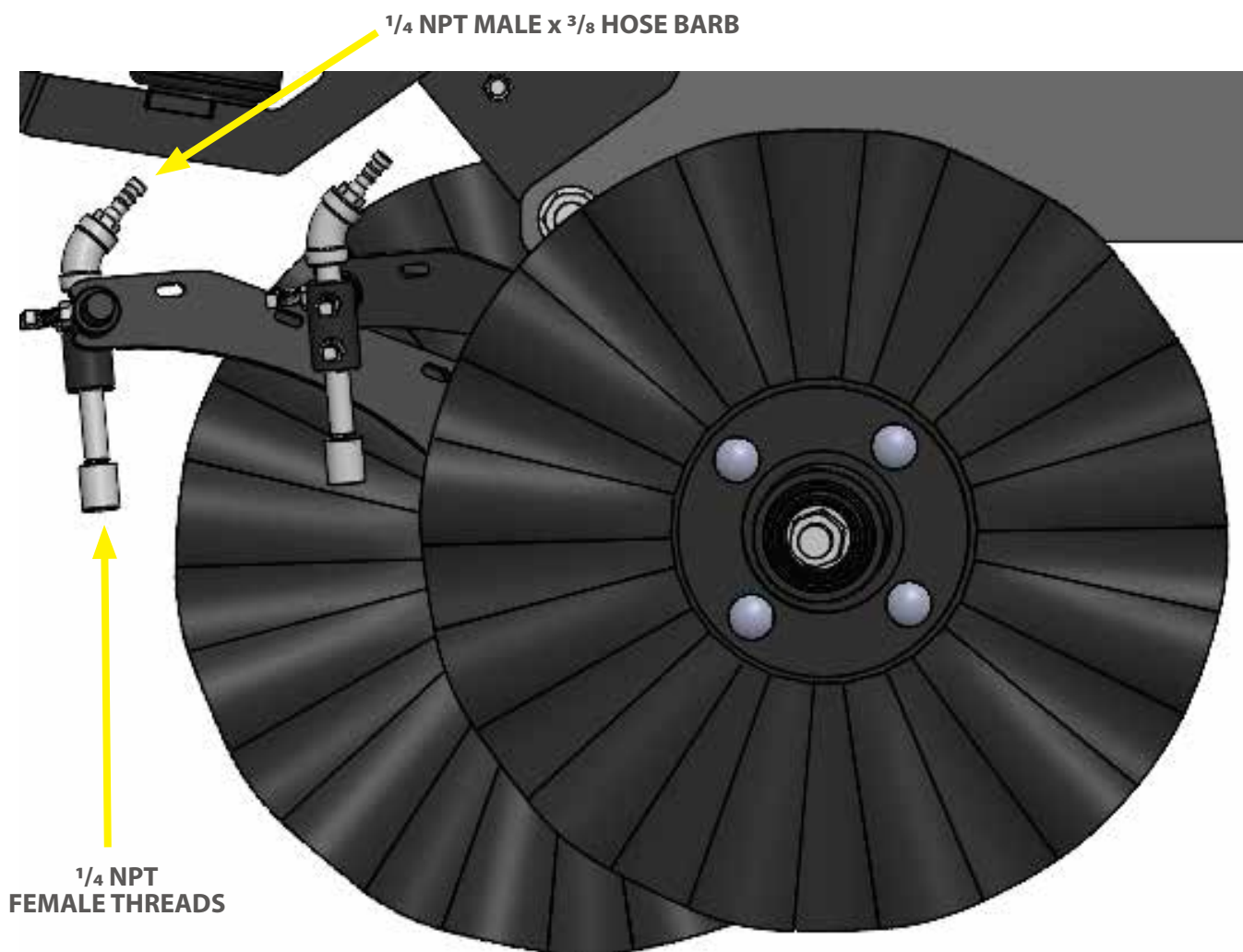



DUAL PLACEMENT LIQUID

- Each nozzle can be placed from 3.5 - 4.75 inches off the center line.
- Nozzles can be adjusted by loosening the set screws on the liquid fertilizer placement arms.
- To prevent splattering of fertilizer, adjust row unit to inject fertilizer in void left by coulters.
- AGROdeviate is not responsible for any crop damage that results from placing fertilizer too close to the root zone. Please consult your agronomist for your individual farm's fertilizer program.

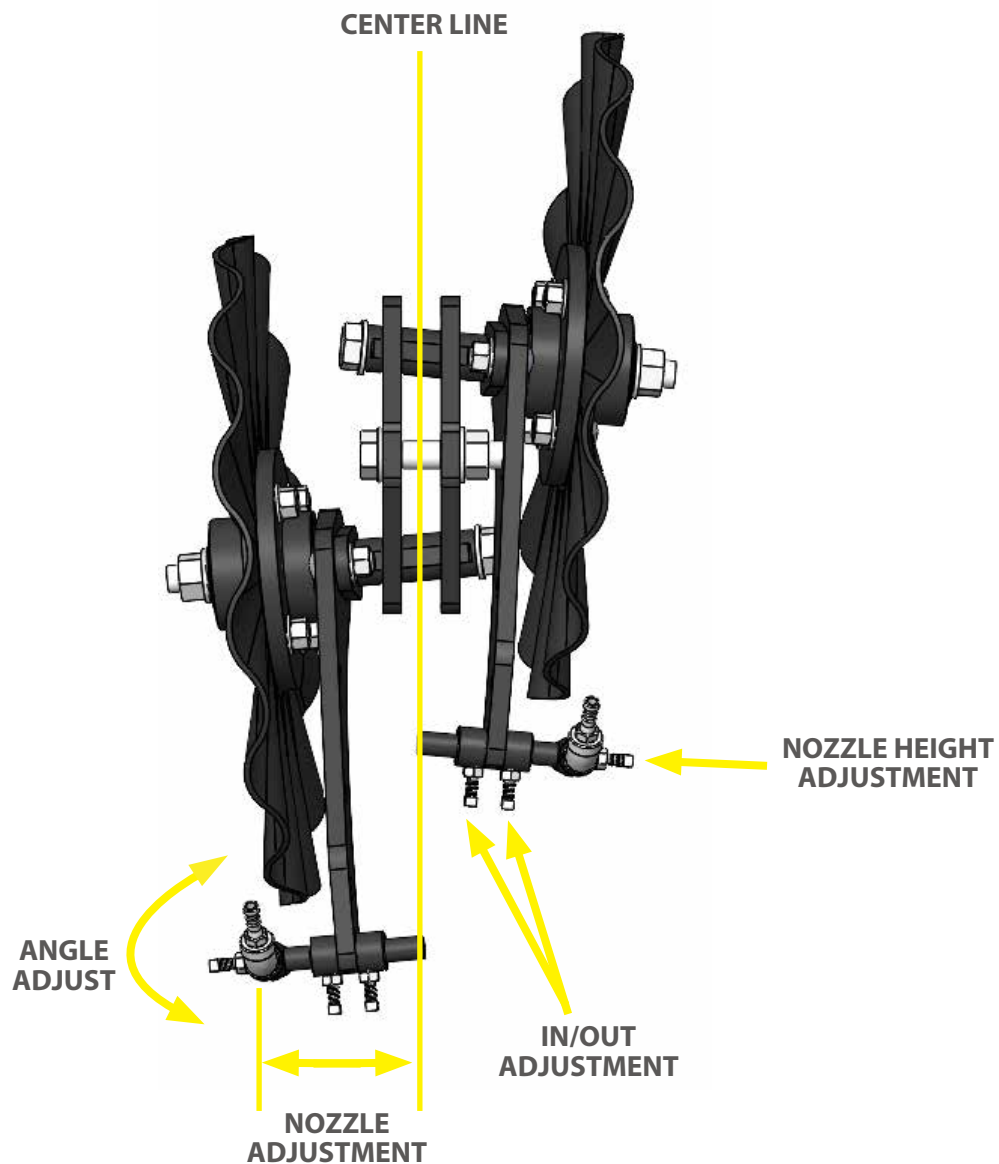



NOTE: This page is intentionally left blank.



NOTE: This page is intentionally left blank.



BAR STANDS

- Bar stands on the VERTISTRIP™ can be set to various heights to accommodate your machine storage and hookup situation.
- There are multiple hole combinations between the stand tube and the receiver tube to achieve the ideal stand height.
- Generally, it is best to find the setting that allows your machine to sit level when parked on the bar stands in the front with the coulters supporting the rear of the machine.
- On soft ground, use wood blocks or steel plates to keep the bar stands and coulters from settling into the ground and prevent the machine from becoming unstable or causing difficulties the next time you want to hook up to the machine.
- Prior to unhooking the machine, check that all hydraulic, electrical, and mechanical connections are disconnected.
- Always secure the bar stands in the “up” position before use.

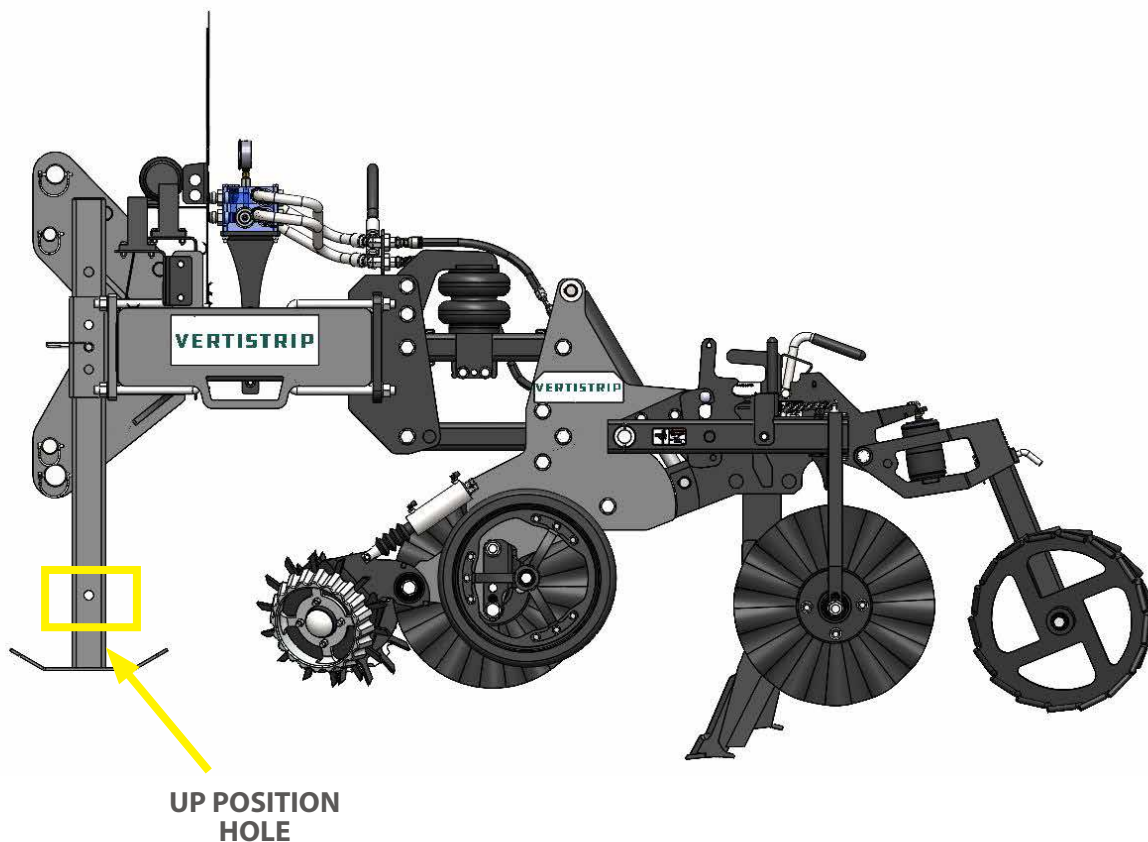



OPERATING TIPS

WHEAT STUBBLE AND SOYBEAN RESIDUE

In conditions with little residue from previous crop, row cleaners may not be necessary and can be adjusted to not contact or barely contact the soil.

CORN STALKS

When strip tilling in standing corn stalks, it is recommended to work between the previous rows, next to the rows, or at a slight angle to the rows of stalks.

When strip tilling on ridges it is recommended to use a root ball puller, stalk chopper, or rolling stalk chopper prior to strip tilling.

Some experimentation may be necessary to produce the best strips for your conditions.

COULTER DEPTH

A steel rod or wooden dowel can be inserted into the middle of the strip to check the depth of action of the coulter.

Adjust the coulters to suit your conditions, fertilizer placement needs, and tillage goals.

DRAFT CONTROL

It may be helpful for overall machine functionality to disable draft control on your tractor.

Disabling draft control will “force” the implement into the ground and make the parallel linkages work to keep each row fully engaged.



OPERATING TIPS

COULTER MACHINE - SPEED RECOMMENDATIONS

A speed of 5 to 10 miles per hour is recommended for optimum results. Faster speeds will result in more soil disturbance, knife blowout, and wear on the machine. Slower speeds may result in inconsistent strips.

Ideal operating speed: 5-8 mph
Minimum operating speed: 4 mph
Maximum operating speed: 10 mph

In most conditions, speeding up will result in more soil disturbance and wear on the machine.

See troubleshooting section for more information on performance issues related to speed.

KNIFE MACHINE - SPEED RECOMMENDATIONS

A speed of 5 to 6.5 miles per hour is recommended for optimum results. Faster speeds will result in more soil disturbance, knife blowout, and wear on the machine. Slower speeds may result in inconsistent strips.

- Ideal operating speed: 5-6.5 mph
- Minimum operating speed: 4 mph
- Maximum operating speed: 8 mph

SPEED EFFECTS

- In most conditions, speeding up will result in more soil disturbance, knife blowout, and wear on the machine.
- In most conditions, slowing down may result in inconsistent strips.
- See troubleshooting section for more information on performance issues related to speed.



PARKING

For long-term parking, see also “**Storage**” below.

1. Choose a parking location that has room for unfolding, is level, has firm soil and is unlikely to develop soft soil in rain. With the implement still hitched, maneuver it to the parking location.

If the implement must be parked folded, leave it hitched to the tractor. Skip steps 2, 4, and 7.

2. Unfold the implement. Set the fold circuit(s) to Float.
3. Lower the implement to just above ground level at the rear of the row units. Set the tractor remotes to Neutral to hold at slight lift. Shut off the tractor and remove the key.
4. Block up coulters to prevent damage or settling.
5. Unplug implement hydraulic hoses and electrical lines from tractor. Set bar stands at appropriate height (see page 53).
6. Start the tractor. Lower the 3-point hitch until the implement is supported by the row units.
7. Disconnect the hitch from the implement.

STORAGE

Store the VertiSTRIP™ where children do not play. If possible, store the implement inside for longer life.

1. Thoroughly clean implement.
2. Park the implement at the storage location as per “Parking” above.
3. Lubricate areas noted under “Maintenance & Lube” beginning on page 61. Apply heavy grease to exposed cylinder rods.
4. Inspect implement for worn or damaged parts. Make repairs and service during the off-season.
5. Use spray paint to cover scratches, chips, and worn areas on the implement to protect the metal.
6. Cover with a tarp if stored outside.



TIP OVER/CRUSHING HAZARD AND EQUIPMENT DAMAGE RISK:

Never unhitch, park, or store a partially folded implement. A partially folded implement could topple backward or forward immediately or at a later time, causing serious injury or death and certain severe equipment damage. When unhitched, the implement is supported at the rear only by row unit tools and spring tension. Slopes, soft soils, and soils later softened by rain are particularly dangerous.



FOLLOWING OPERATION

- Store the unit in an area away from human activity.
- Do not park equipment where it will be exposed to livestock for long periods of time. Damage and livestock injury could result.
- Do not permit children to play on or around the stored unit.
- Make sure all parked machines are on a hard, level surface.



PERFORMING MAINTENANCE

- Good maintenance is your responsibility. Poor maintenance is an invitation to trouble.
- Before working on this machine, stop the towing vehicle, set the brakes, shut off the engine and remove the ignition keys.
- Be certain all moving parts on attachments have come to a complete stop before attempting to perform maintenance.
- Always use the proper tools or equipment for the job at hand.
- Use extreme caution when making adjustments.
- Follow the torque chart in this manual when tightening bolts.
- Replace all shields and guards after servicing and before moving.
- After servicing, be sure all tools, parts and service equipment are removed.
- Never replace hex bolts with less than Grade 5 bolts unless otherwise specified. Refer to **Bolt Torque Chart** for head identification marking.
- Where replacement parts are necessary for periodic maintenance and servicing, genuine factory replacement parts must be used to restore your equipment to original specifications. The manufacturer will not claim responsibility for use of unapproved parts and/or accessories and other damages as a result of their use.
- If equipment has been altered in any way from the original design, the manufacturer does not accept any liability for injury or warranty.
- A first aid kit should be kept readily accessible while performing maintenance on this equipment.



VERTISTRIP™ DO'S AND DON'TS

- DO follow all safety precautions in this manual.
- DO locate and familiarize yourself with the various Safety Signs and instructional decals prior to operation.
- DO inspect equipment for damage and wear before use; repair as needed.
- DO use caution when connecting pressurized systems, such as hydraulics and pneumatics.
- DO follow recommend maintenance.
- DO level the toolbar for optimum performance.
- DO lift implements completely out of the soil before turning the unit.
- DO use caution when moving large equipment. Using a spotter is recommended when working around obstacles on the ground and/or overhead.
- DON'T fold the toolbar with locking pins in the locked position.
- DON'T over-pressurize the hydraulic system; VertiSTRIP™ hydraulics are designed for 3,000 PSI MAX working pressure.
- DON'T exceed the limits of a piece of machinery.
- DON'T modify equipment from factory build; modification may compromise equipment safety and integrity and will void product warranty.

TROUBLESHOOTING



Shared Troubleshooting		
Problem	Possible Cause	Solution
Tooling not engaging with the soil as desired.	Toolbar not running low enough.	Adjust hitch setting in tractor to allow 3-point hitch to run lower.
	Toolbar not level.	Adjust top link and/or hitch arm heights (See page 21/25).
	Down pressure springs set too light.	Adjust air pressure to increase downforce.
Row units plug with residue between front coulter and double coulter/row coulter.	Toolbar height/levelness.	Adjust toolbar height/level.
	Wet/damp conditions preventing good residue flow.	Wait for ground to dry.
		Adjust ground speed to improve residue flow.
Discs not turning.	Bearing going out.	Check/replace bearing.
	Obstruction holding disc in place.	Remove obstructions and check row unit set up.

TROUBLESHOOTING



Knife Machine Troubleshooting		
Problem	Possible Cause	Solution
Blade is not turning.	Blade not making contact with the ground.	Adjust blade depth to hold blades in ground.
	Residue build-up is preventing the blade from turning.	Remove residue build-up from FlexBerm™.
	Bearing hub bolt is bent or warped.	Replace bearing hub bolt.
Arms are not floating up and down properly.	Handle may not be in line.	Refer to page 53 and make sure handle is set correctly according to desired depth.
Blade Assembly rotates freely.	Spring is broken.	Replace spring. Refer to pages 101 & 102 and contact Hawkins for replacement spring
	Handle may not be engaged.	Refer to page 54 to make sure handle is fully engaged.
Little to no berm showing in field.	Blade angle may not be aggressive enough.	Refer to page 54 and set the blade at a more aggressive angle.
Too much berm showing in the field.	Blade angle may be set too aggressively.	Refer to page 54 and set the blade at a less aggressive angle.
Row units plug with residue between front coulter and knife.	Wet/damp conditions preventing good residue flow.	Decrease ground speed to improve residue flow.
		Adjust row cleaners up slightly to decrease residue load.
Row units plug with residue between row cleaner and knife.	Toolbar height/levelness.	Adjust toolbar height/level.

TROUBLESHOOTING



Knife Machine Troubleshooting		
Problem	Possible Cause	Solution
Row units plug with residue between row cleaner and knife.	Too much residue at knife.	Refer to page 35 to increase row cleaner down pressure to move residue away from the knife.
		Adjust ground speed to improve residue flow.
	Wet/damp conditions preventing good residue flow	Adjust ground speed to improve residue flow.
Row units plug with residue between knife and berm building discs.	Not enough space for residue between knife and discs.	Refer to page 55 to increase width between disks and knife.
	Heavy residue conditions.	Adjust ground speed to improve residue flow.
	Wet/damp conditions preventing good residue flow.	Adjust ground speed to improve residue flow.
Residue plugs between row units.	Not enough space for residue between knife and discs.	Refer to page 55 to increase width between disks and knife.
	Wet/damp conditions preventing good residue flow.	Adjust ground speed to improve residue flow.

TROUBLESHOOTING



Knife Machine Troubleshooting		
Problem	Possible Cause	Solution
Berm isn't sized/shaped as desired.	Berm building discs not optimized.	Adjust berm building discs as described on pages 53-55 to optimize berm.
	Rear finishing tool not optimized.	Adjust rear finishing tool.
System trips too easily/knives won't stay engaged.	Pressure relief valve set too low.	Refer to the chart on page 59 to increase pressure.
Knives are shearing bolts, system is not tripping.	Pressure relief valve set too high.	Refer to the chart on page 59 to decrease system pressure.

TROUBLESHOOTING



Coulter Machine Troubleshooting		
Problem	Possible Cause	Solution
Row units plug with residue between front coulter and double coulter.	Wet/damp conditions preventing good residue flow.	Refer to page 35 to increase row cleaner down pressure.
Residue plugs between row units.	Rows are not configured correctly.	Make sure row units are configured as show on page 45.
	Heavy residue.	Adjust air pressure on row cleaners for more cleaning.
		Adjust ground speed to improve residue flow.
	Wet/damp conditions preventing good residue flow.	Wait for conditions to improve.
Berm isn't sized/shaped as desired.	Row cleaners not optimized.	Refer to page 35 to adjust row cleaner pressure.
	Rear coulters not optimized.	Adjust depth of coulters to improve shape.
	Rear finishing tool not optimized.	Refer to page 44 to adjust rear finishing tool.



NOTE: This page is intentionally left blank.



MAINTENANCE

- Proper maintenance will ensure longevity and optimum performance of your Hawkins equipment.
- Visual inspection is recommended before each use. Check for loose bolts, worn parts, cracked welds and other damage. Replace and repair as needed.
- In addition to visual inspection before each use, carefully inspect hydraulic components every 100 hours for leaks, excessive wear, swelling and damage. Leaks should be corrected by tightening the fittings according to the **Hydraulic Fitting Torque Chart** or replacing components. Replace any components showing signs of excessive wear, swelling or damage.
- Always replace bolts with the same grade, refer to **Bolt Torque Chart** for grade identification. Tighten bolts according to **Bolt Torque Chart**.
- Always replace parts with Hawkins parts only.
- We recommend greasing each grease zerk on the toolbar hinge weekly. Grease all attachment grease zerks weekly, or according to specified lubrication schedule.
- Before long-term storage (3 months or more) clean debris from equipment and touch-up paint to prevent corrosion.
- Store in a flat dry place away from human activity and livestock.
- After long-term storage (3 months or more) visually inspect equipment and carefully inspect all components. Especially parts more easily affected by weather damage, such as hydraulic hoses and wiring. Repair and replace as needed before use.



DAILY MAINTENANCE

1. Inspect row units for any loose or missing hardware.

WEEKLY MAINTENANCE

1. Grease the toolbar hinges - three (3) grease zerks on each hinge.
2. Grease gauge wheel bearings.

YEARLY MAINTENANCE

1. Clean machine off.
2. Grease all grease zerks.
3. Replace all parts as necessary.
4. Check Bolt Torque on Hubs.

Toolbar Hinge

Gauge Wheel

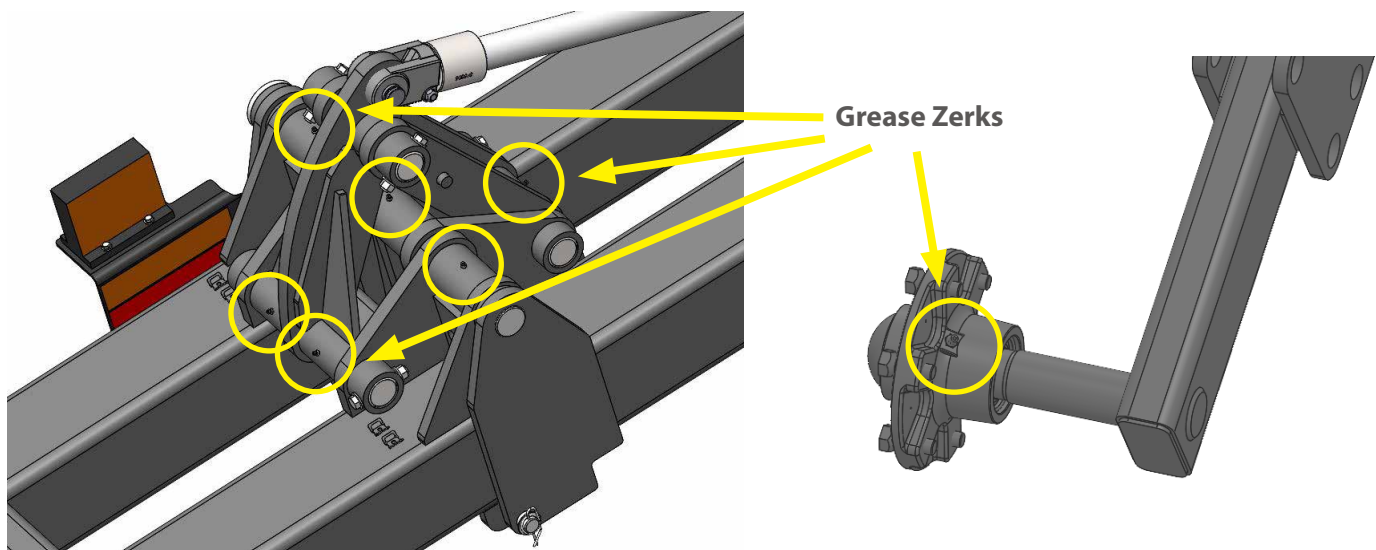



BLEEDING FOLD HYDRAULICS

To function properly, the hydraulics must be free of air. If hydraulics have not been bled, they will operate with jerky, uneven motions and could cause wings to drop rapidly during folding or unfolding. If hydraulics were not bled during initial implement setup or if you replace a part in hydraulic system during the life of the implement, complete the following procedures:

1. Check hydraulic fluid level in tractor reservoir and fill to proper level. Add fluid to system as needed.
2. With implement unfolded and fold cylinders completely extended, disconnect rod end pins and swing the cylinders so they will not contact anything when extended.
3. Loosen rod end hose fittings (1) at a ORB connection.
4. Slowly supply oil to rod end of fold cylinders until oil appears at loosened hose fitting. Tighten fitting and completely retract fold cylinders.
5. With cylinders completely retracted, loosen base end hose fittings (2) at ORB connection.
6. Slowly supply oil to base end of fold cylinders until oil appears at loosened hose fitting. Tighten base end hose fitting and cycle fold cylinders in and out several times.
7. Re-pin cylinder rod clevises.

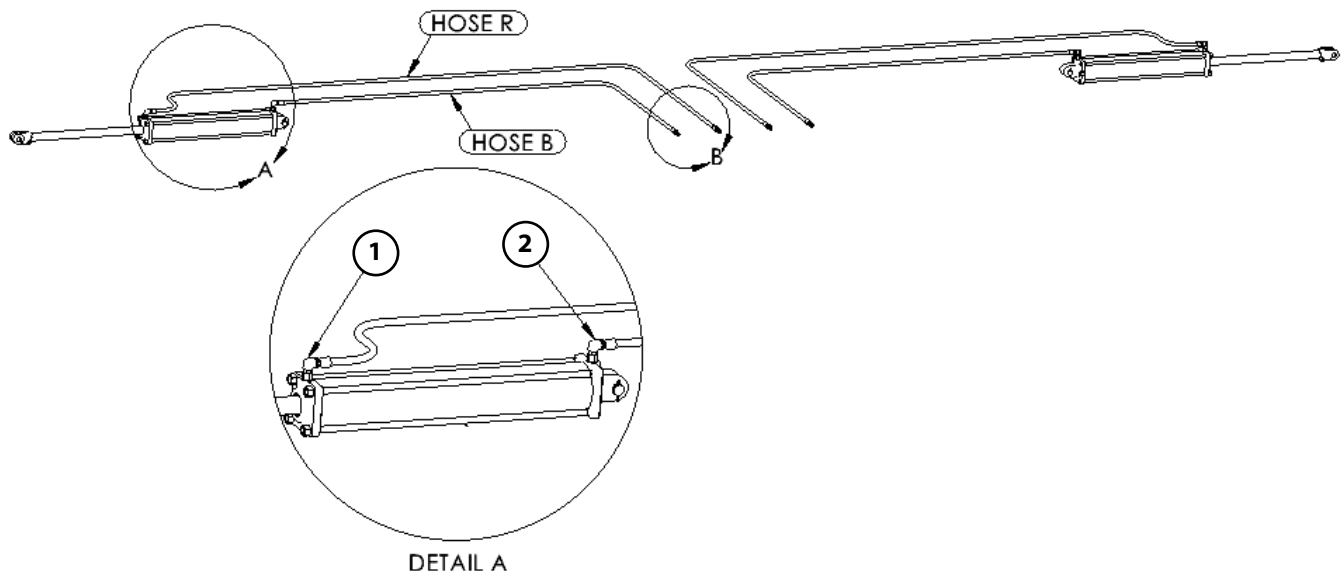

HIGH PRESSURE FLUID - DANGER

- Use safe practices. Fluid injection can occur; will result in death or serious injury.
- Hazards may include, but are not limited to, injury beyond the entry point, over pressurized components, damaged components, components with excessive wear, swollen components, ect.



CHECKING BOLT TORQUE

The table shown below gives correct torque values for various bolts and capscrews. Tighten all bolts to the torques specified in chart unless otherwise noted. Check tightness of bolts periodically, using bolt torque chart as a guide. Replace hardware with the same grade bolt.

BOLT TORQUE CHART

Torque Specifications						
Bolt Diameter	Bolt Torque*					
	SAE Grade 2		SAE Grade 5		SAE Grade 8	
INCH	lbft	(Nm)	lbft	(Nm)	lbft	(Nm)
1/4	6	(8)	9	(12)	12	(17)
5/16	10	(13)	19	(25)	27	(36)
3/8	20	(27)	33	(45)	45	(63)
7/16	30	(41)	53	(72)	75	(100)
1/2	45	(61)	80	(110)	115	(155)
9/16	70	(95)	115	(155)	165	(220)
5/8	95	(128)	160	(215)	220	(305)
3/4	165	(225)	290	(390)	400	(540)
7/8	170	(230)	420	(570)	650	(880)
1	226	(345)	630	(850)	970	(1320)

BOLT HEAD IDENTIFICATION

Grade 2

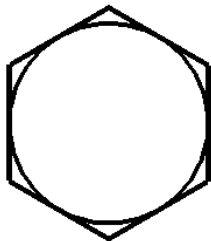

Grade 5

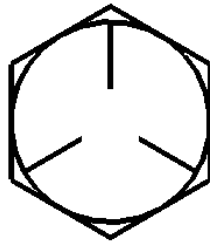

Grade 8

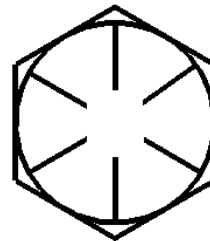



HYDRAULIC FITTING IDENTIFICATION

Hydraulic fitting styles, types and sizes are numerous and at times easily confused. The chart below shows the most common types and sizes of hydraulic fittings for the industry, male ends depicted. This chart is printed at 1 to 1 for ease of identification.

NPTF (National Pipe Taper Fuel) uses tapered threads to create a seal.

ORB (O-Ring Boss) uses an O-ring to seal after threads.

JIC (Joint Industry Council) 37-degree flare sealing surface before threads.

ORFS (O-Ring Face Seal) uses an O-ring to seal before threads.



-4 NPTF



-4 ORB



-4 JIC



-4 ORFS

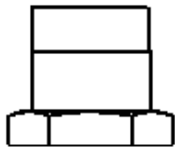

-6 NPTF



-6 ORB

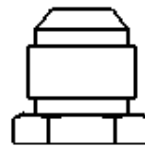

-6 JIC

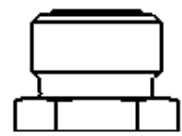

-6 ORFS

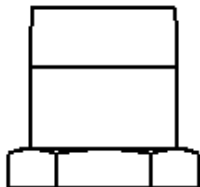

-8 NPTF

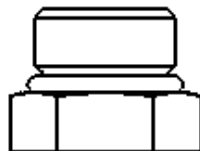

-8 ORB

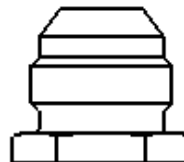

-8 JIC

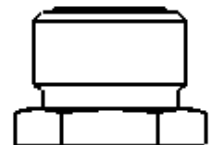

-8 ORFS

N/A

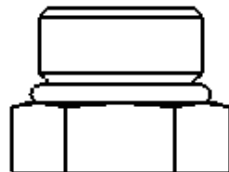

-10 ORB

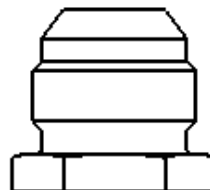

-10 JIC

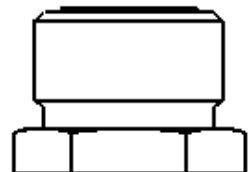

-10 ORFS

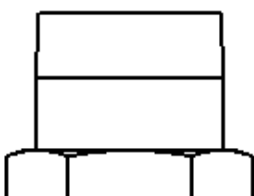

-12 NPTF

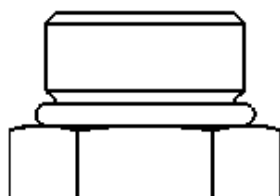

-12 ORB

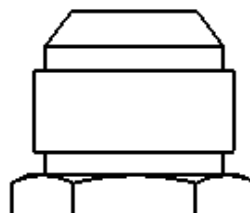

-12 JIC

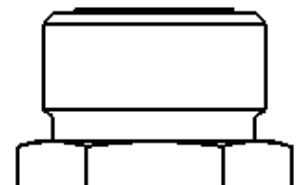

-12 ORFS



CHECKING HYDRAULIC FITTINGS

- Before connecting hydraulic fittings, check that fittings are clean and undamaged. Replacement fittings and hoses are available from VertiSTRIP™.
- Ensure O-ring(s) are installed properly as shown in the image. (ORB fitting above, ORFS fitting below)
- “Wet Torque” fittings according to the chart below. Wet Torque is the process of lubricating all threads, O-rings and sealing surfaces with the hydraulic fluid used in the system. Then tightening to a specified torque.
- Do not force fittings together. Ensure male and female are of the same type and size, align sealing surfaces and threads properly.
- Do not apply force to a connection or use the connection as support. Doing so may damage components and/or cause the connection to leak.

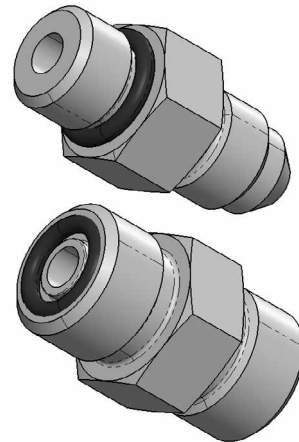

HYDRAULIC FITTING TORQUE CHART

Dash Size	Torque lbft (Nm)			
	NPTF	ORB	JIC	ORFS
-4	12-16 (16-22)	10-15 (14-20)	11-13 (15-18)	10-12 (14-16)
-6	14-32 (19-43)	17-21 (23-28)	20-22 (27-30)	18-20 (24-27)
-8	32-40 (43-54)	30-35 (41-47)	43-47 (58-64)	32-35 (43-47)
-10	-	30-35 (41-47)	55-65 (75-88)	45-50 (61-68)
-12	40-48 (54-65)	30-35 (41-47)	80-90 (108-122)	65-70 (88-95)



INDEX

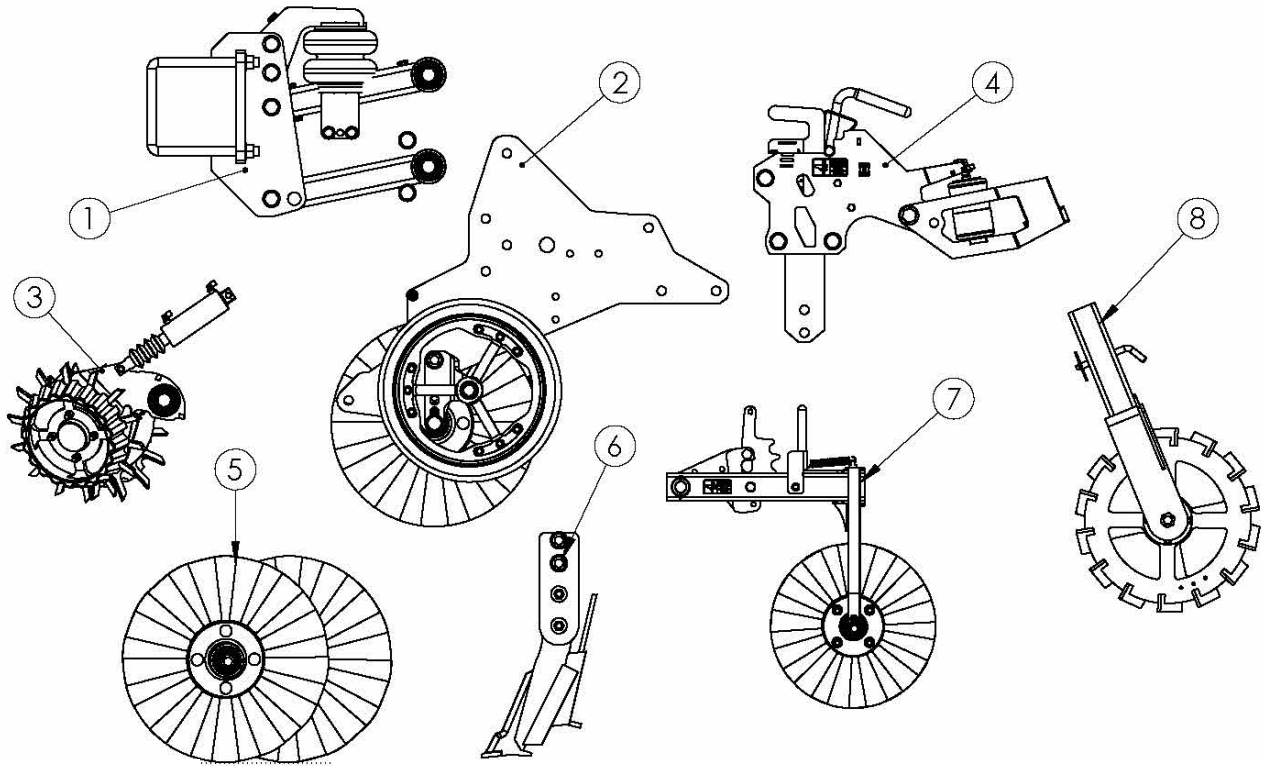

Item Number	Description	Page Number
1	MOUNT & PARALLEL LINKAGE	70
2	MAIN BODY, DEPTH WHEELS, FRONT COULTER	71-72
3	ROW CLEANER	73-74
4	SHANK HOUSING ASSEMBLY	75-76
5	DUAL COULTER ASSEMBLY	77-78
6	KNIFE ADAPTOR	69-82
7	FLEXBERM	
8	OPTIMIZER FINISHING SYSTEM	
NOT SHOWN	HYDRAULIC TRIP COMPONENTS	
NOT SHOWN	FERTILIZER ATTACHMENTS	83
NOT SHOWN	AIR CONTROLLER AND AIR SYSTEM	85



ROW CLEANERS

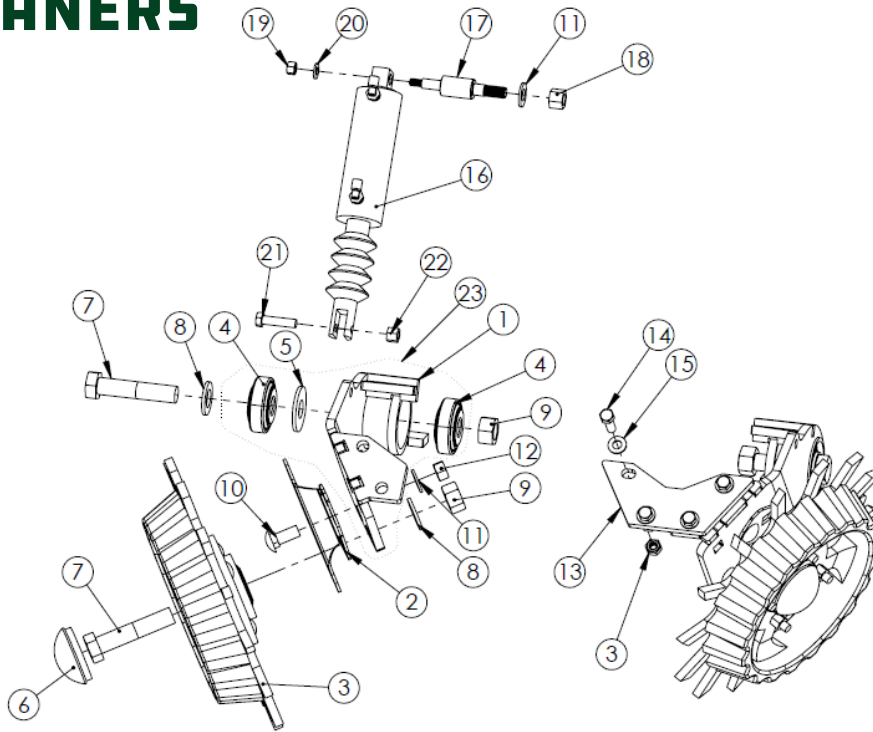

Item #	Part #	Description	Quantity
1	321560	ROW CLEANER RH ARM W/O BEARINGS	1
NOT SHOWN	321559	ROW CLEANER LH ARM W/O BEARINGS	1
2	321909	RH SCRAPER FINISHED	1
NOT SHOWN	321908	LH SCRAPER FINISHED	1
3	321565	RH FINGER BLADE ASSEMBLY	1
NOT SHOWN	321566	LH FINGER BLADE ASSEMBLY	1
4	305017	3/4 SYMETRIC BEARING	4
5	413012	3/4 FLAT WASHER USS Z/C	2
6	GWX20016	DUST CAP	2
7	411590	3/4-10 X 3 1/2 GR5 Z/C	4
8	413072	3/4 FLAT WASHER SAE Z/C	4
9	410012	3/4-10 NUT CENTER LOCK Z/C	4
10	411729	1/2-13 X 1 1/4 CARRIAGE BOLT GR2 Z/C	2

PARTS GUIDE



ROW CLEANERS

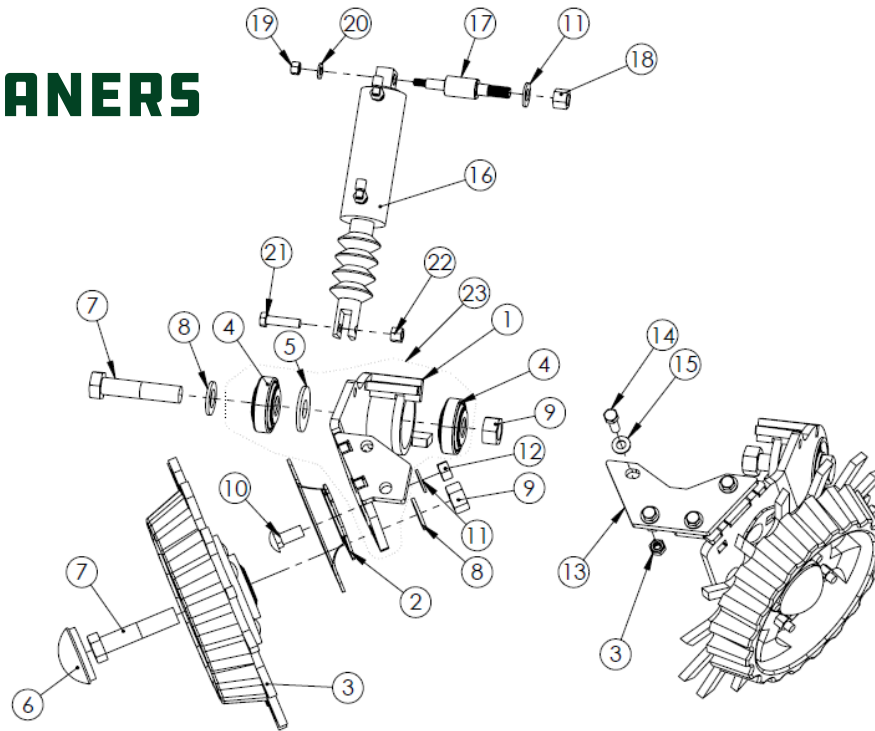

Item #	Part #	Description	Quantity
11	413007	1/2 FLAT WASHER SAE Z/C	3
12	410008	1/2-13 NUT CENTER LOCK Z/C	2
13	321530	FRONT MOUNTING PLATE	1
14	411143	3/8-16 X 1.25 GR5 Z/C	4
15	413009	3/8 FLAT WASHER SAE Z/C	4
16	321563	CLEAN SWEEP AIR CYL.	1
17	321564	AIR CYL. MOUNTING PIN	1
18	305103	1/2-13 HEX NUT NYLON LOCK Z/C	1
19	305168	5/16-18 NUT NYLON LOCK Z/C	1
20	413005	5/16 FLAT WASHER SAE Z/C	1
21	411509	3/8-16 X 1 1/2 GR5 Z/C	1
22	305106	3/8-16 NYLOC NUT, ZC	1
23	321562	ROW CLEANER RH ARM WITH BEARINGS	1
NOT SHOWN	321561	ROW CLEANER LH ARM WITH BEARINGS	1



FINGER BLADES

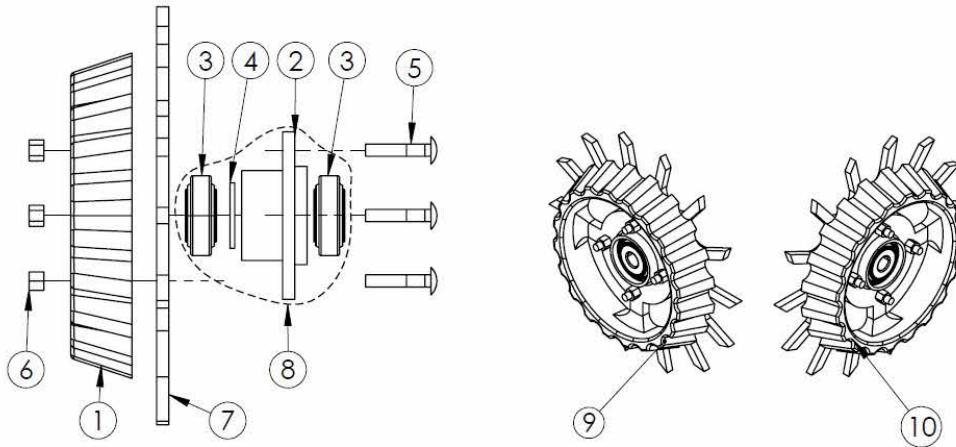

Item Number	Part #	Description	Quantity
1	321541	ROW CLEANER DEPTH BAND	1
2	321546	ROW CLEANER HUB WELDMENT W/O BEARINGS	1
3	305017	3/4 SYMETRIC BEARING	2
4	413012	3/4 FLAT WASHER USS Z/C	1
5	305145	3/8-16 X 2 CARRIAGE BOLT	4
6	305106	3/8-16 NYLOC NUT, ZC	4
7	321899	ROW CLEANER 13" FINGER BLADE	1
8	321547	ROW CLEANER HUB WELDMENT WITH BEARINGS	1
9	321565	RH FINGER BLADE ASSEMBLY	1
10	321566	LH FINGER BLADE ASSEMBLY	1

321566 & 321565 (RH & LH ASSEMBLIES) USE IDENTICAL PARTS



MOUNTS & PARALLEL LINKAGES

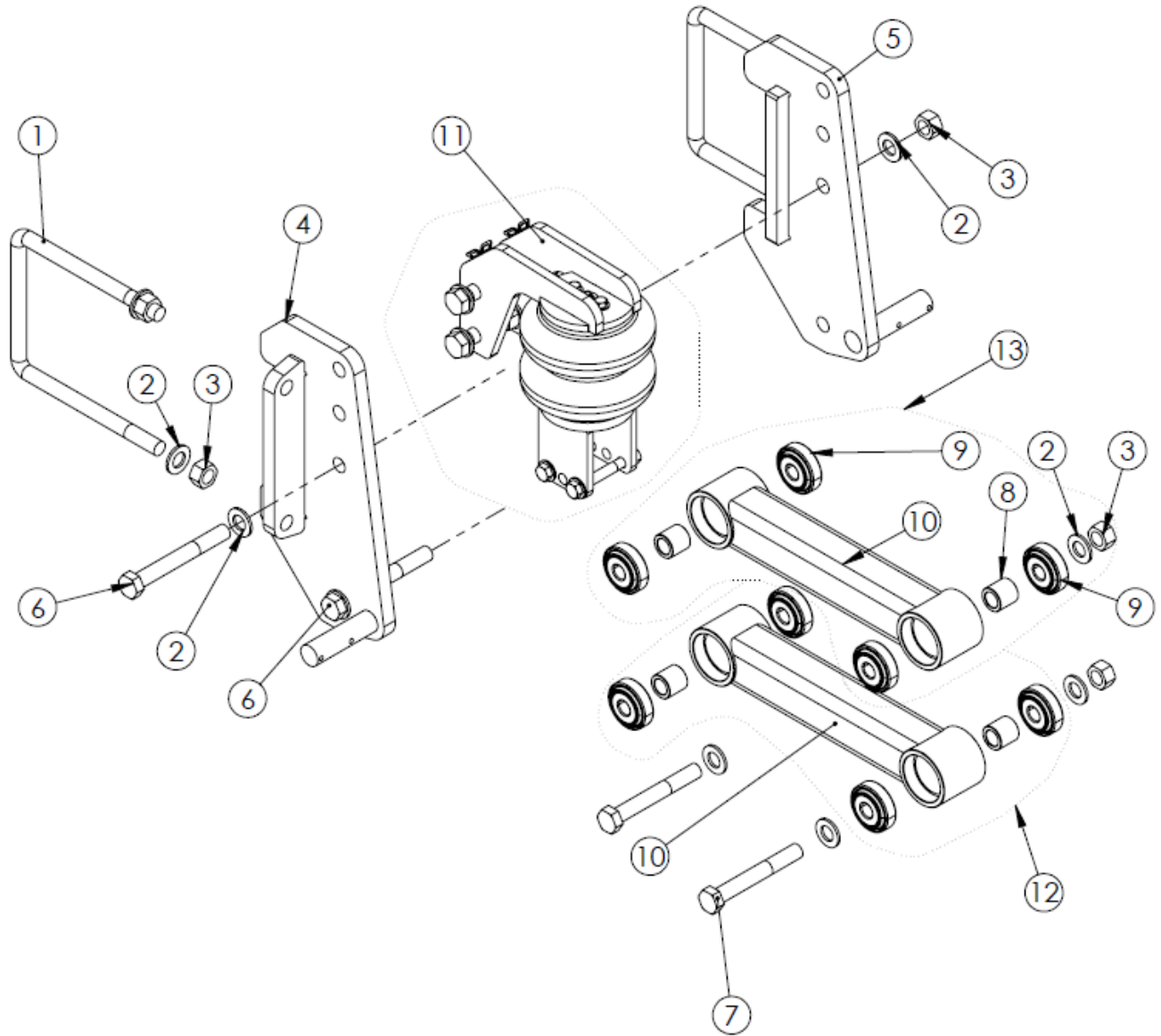



MONTS & PARALLEL LINKAGES

Item Number	Part #	Description	Quantity
1	415004	"3/4-10 UBOLT X 7W X 9H"	2
2	413072	"3/4 FLAT WASHER SAE Z/C"	12
3	410012	"3/4-10 NUT CENTER LOCK Z/C"	8
4	333324	"HD LH FRONT MOUNT WELD"	1
5	333325	"HD RH FRONT MOUNT WELD"	1
6	411597	3/4-10 X 6 GR5 Z/C	2
7	411595	"3/4-10 X 5 1/2 GR5 Z/C"	2
8	333310	BEARING SPACER	4
9	305017	"3/4 SYMETRIC BEARING"	8
10	333311	WELD ASSEMBLY	1
11	333313	PARALLEL LINK LOWER ARM ASSEMBLY	1
12	333314	PARALLEL LINK UPPER ARM ASSEMBLY	1
13	333500	AIR DF KIT	1



AIR DOWNFORCE

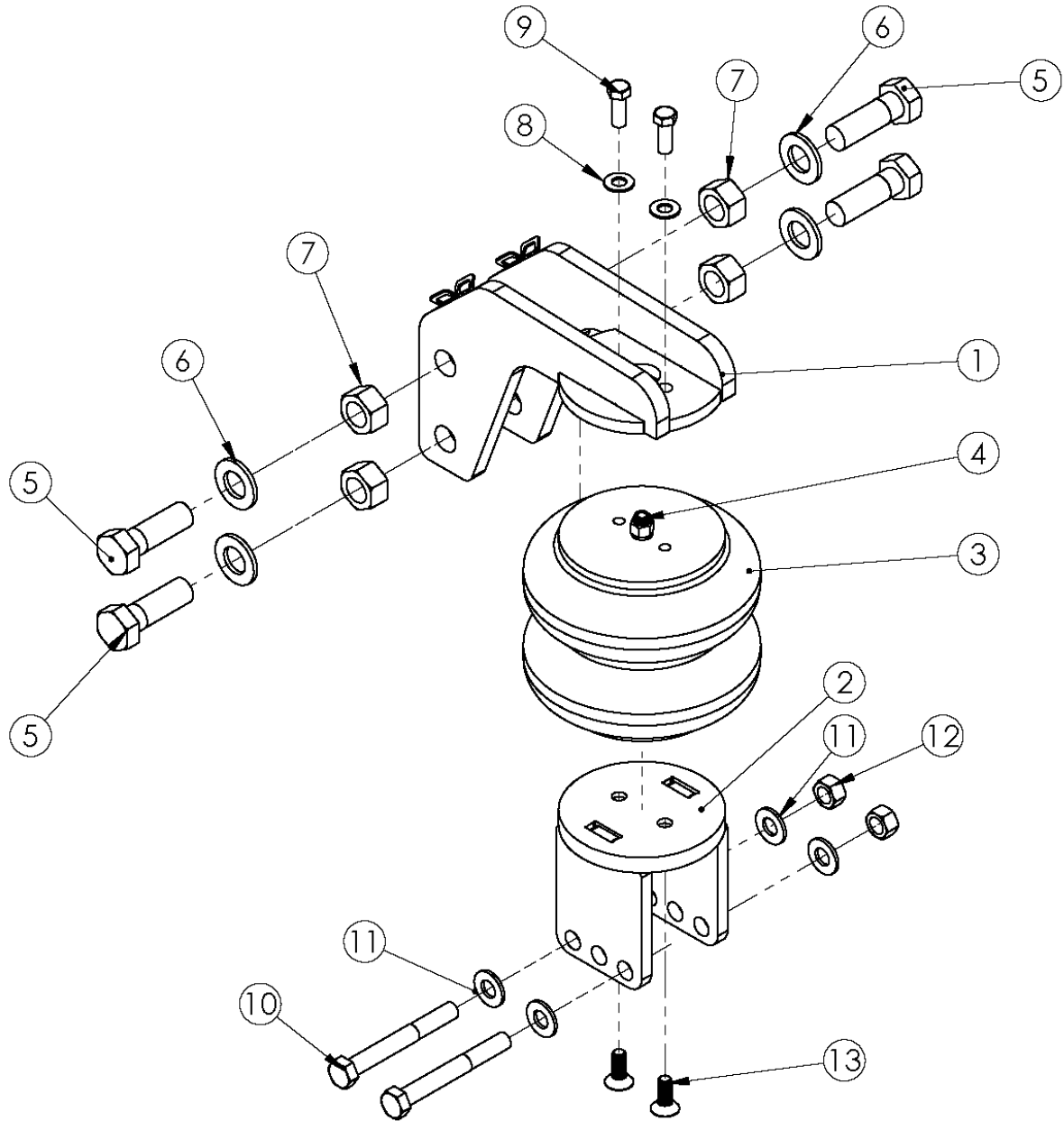



AIR DOWNFORCE

Item Number	Part #	Description	Quantity
1	333501	TOP BAG MOUNT	1
2	333502	LOWER AIR BAG MOUNT	1
3	321586	AIR SPRING	1
4	457406	FITTING STRAIGHT 1/4 NPT TO 1/4 OD	1
5	411585	3/4-10 X 2 1/4 HEX BOLT GR5 Z/C	4
6	413072	3/4 FLAT WASHER SAE Z/C	4
7	412012	3/4-10 HEX NUT GR2 Z/C	4
8	413009	3/8 FLAT WASHER SAE Z/C	2
9	411506	3/8-16 X 1 HEX BOLT GR5 Z/C	2
10	411193	1/2-13 X 4 HEX BOLT GR5 Z/C	2
11	413007	1/2 FLAT WASHER SAE Z/C	4
12	410008	1/2-13 HEX NUT CENTER LOCK GRA Z/C	2
13	414515	3/8-16 X 1 FLAT SOCKET HEAD CAP SCREW	2



DEPTH WHEELS

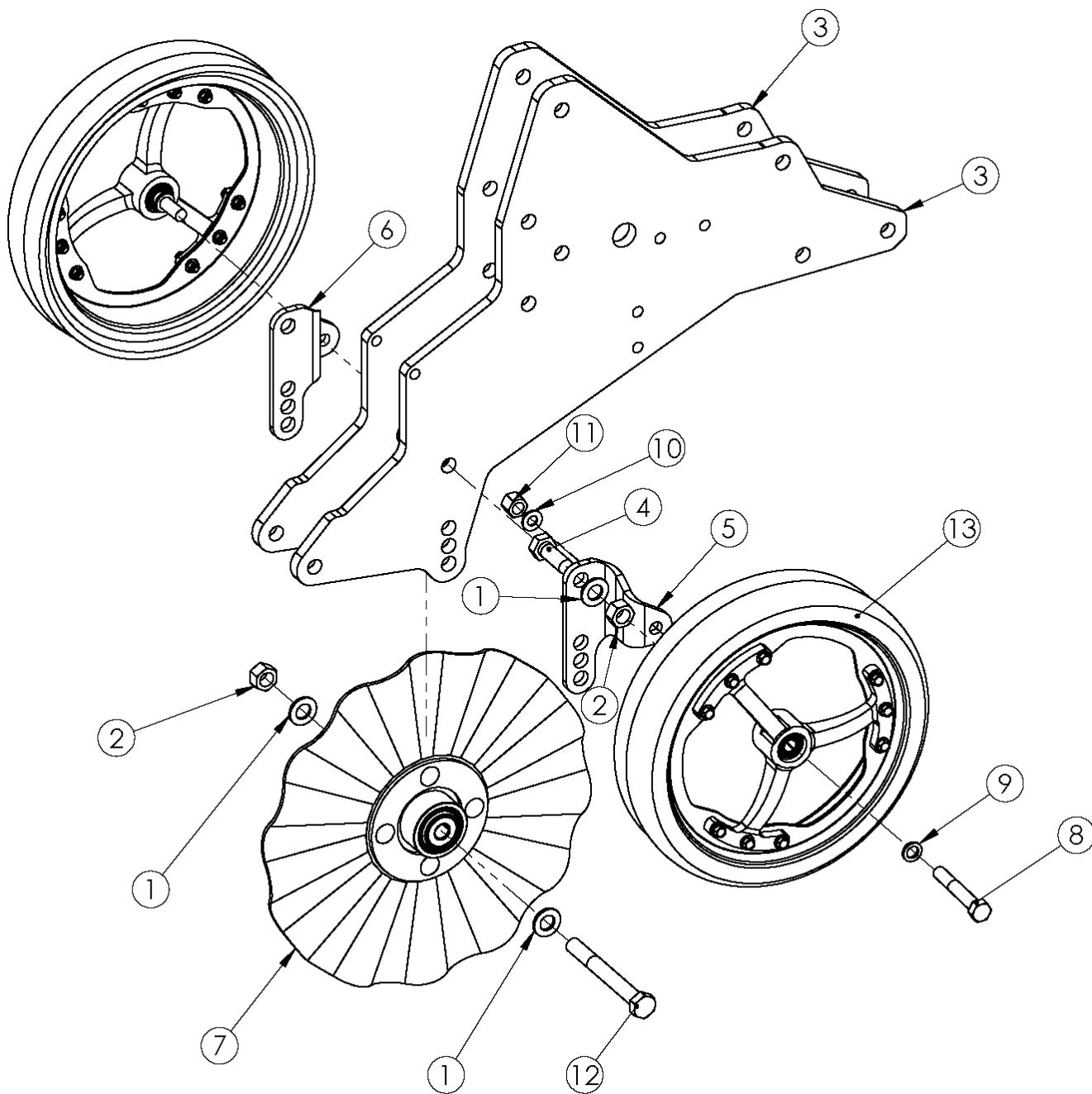



DEPTH WHEELS

Item Number	Part #	Description	Quantity
1	413072	3/4 FLAT WASHER SAE Z/C	6
2	410012	3/4-10 NUT CENTER LOCK Z/C	3
3	333513	VERTISTRIP SIDE PLATE FINISHED	2
4	411584	3/4-10 X 2 GR5 Z/C	2
5	333270	VERTISTRIP LH DEPTH WHEEL BRACKET FINISHED	1
6	333269	VERTISTRIP RH DEPTH WHEEL BRACKET FINISHED	1
7A	333306	VERTISTRIP 18" WAVY	1
7B	333384	VERTISTRIP 18"VT(NOT SHOWN)	1
8	411222	5/8-11 X 4 GR5 Z/C	2
9	333205	10GA X 5/8 X 1 MACHINE BUSHING	4
10	413007	1/2 FLAT WASHER SAE Z/C	2
11	409009	5/8-11 NUT NYLON LOCK Z/C	2
12	411598	3/4-10 X 6 1/2 GR5 Z/C	1
13	333398	SPOKED POLY GAUGE WHEEL	2



SHANK HOUSING

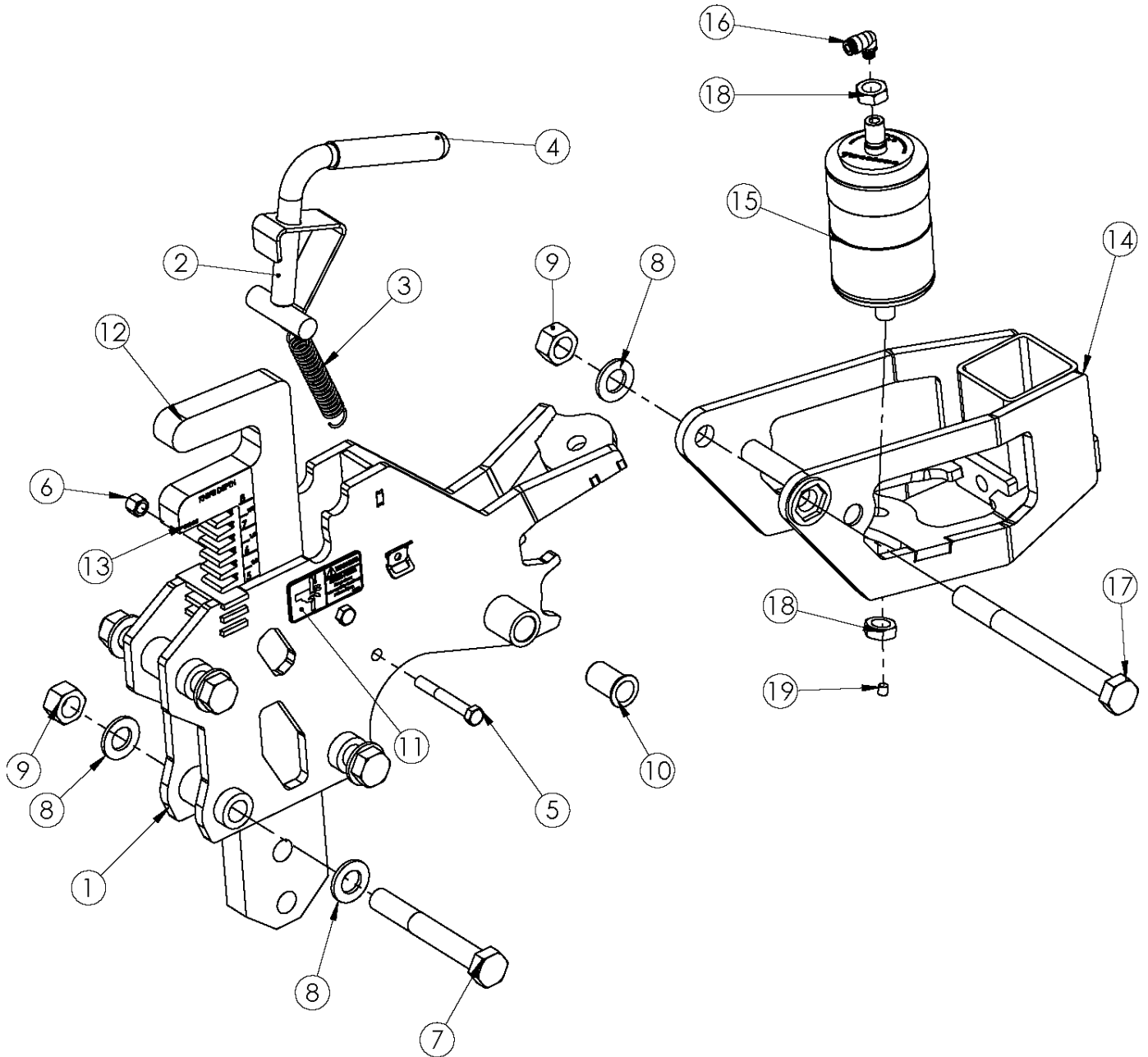



SHANK HOUSING

Item Number	Part #	Description	Quantity
1	333519	VERTISTRIP SHANK HOUSING ASSEMBLY	1
2	316016	ADJUSTMENT HANDLE WELDMENT	1
3	321651	SPRING	1
4	321673	RUBBER GRIP	1
5	411149	3/8-16 X 2 3/4 GR5 Z/C	2
6	305106	3/8-16 NUT NYLON LOCK Z/C	2
7	411595	3/4-10 X 5 1/2 GR5 Z/C	3
8	413072	3/4 FLAT WASHER SAE Z/C	7
9	410012	3/4-10 NUT CENTER LOCK Z/C	4
10	321499	POLY BUSHING	2
11	461212	WARNING PINCH POINT 1 1/2 X 3	2
12	333278	VERTISTRIP SHANK	1
13	333493	KNIFE DEPTH DECAL	1
13B	333550	COULTER DEPTH DECAL(NOT SHOWN)	1
14	333293	VERTISTRIP REAR BASKET FRAME	1
15	321498	AIR BAG	1
16	457405	90° 1/4 AIR FITTING	1
17	411600	3/4-10 X 8 GR5 Z/C	1
18	412410	5/8 JAM NUT	2
19	456150	BRASS PLUG	1

PARTS GUIDE



DUAL COULTER ASSEMBLY

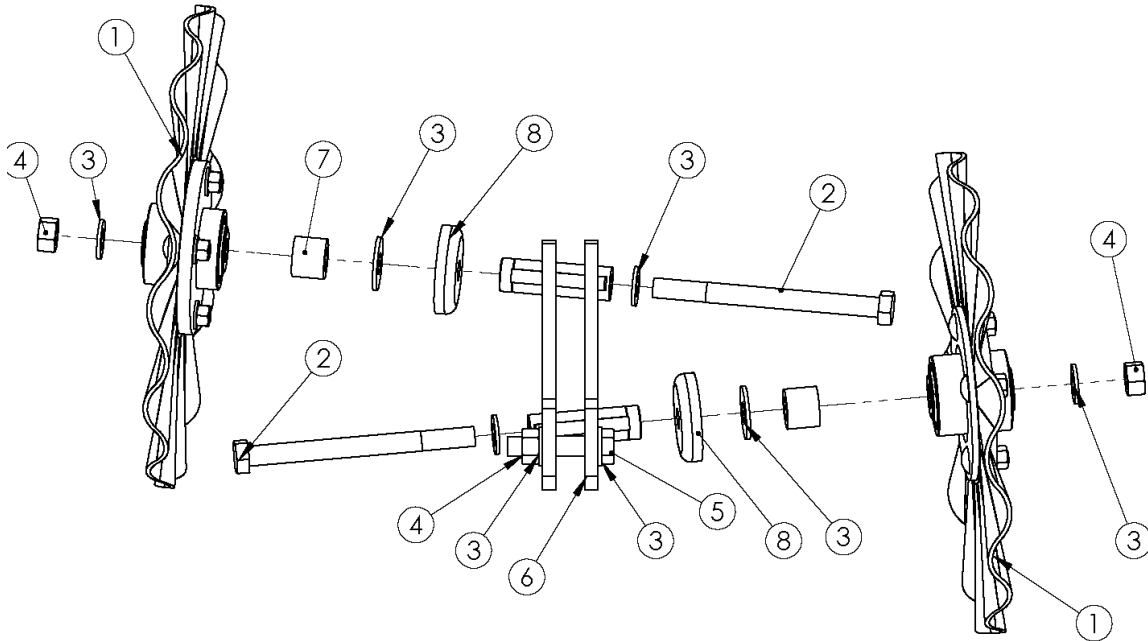

Item Number	Part #	Description	Quantity
1A	333306	VERTISTRIP 18" WAVY	2
1B	333383	VERTISTRIP 18" VT LH	1
1C	333384	VERTISTRIP 18" VT RH	1
2	411601	3/4-10 X 8 1/2 GR5 Z/C	2
3	413072	3/4 FLAT WASHER SAE Z/C	8
4	410012	3/4-10 NUT CENTER LOCK Z/C	4
5	411590	3/4-10 X 3 1/2 GR5 Z/C	2
6A	333530	VERTISTRIP LH 5+5 DUAL COULTER WELD	1
6B	333531	VERTISTRIP RH 5+5 DUAL COULTER WELD	1
7	333553	COULTER SPACER	2
8	305201	VERTISTRIP BEARING SHIELD	2

BEFORE SERIAL NUMBER: 292190224

6A	333392	VERTISTRIP RH 5+5 DUAL COULTER WELD	1
6B	333391	VERTISTRIP LH 5+5 DUAL COULTER WELD	1

PARTS GUIDE



COULTERS

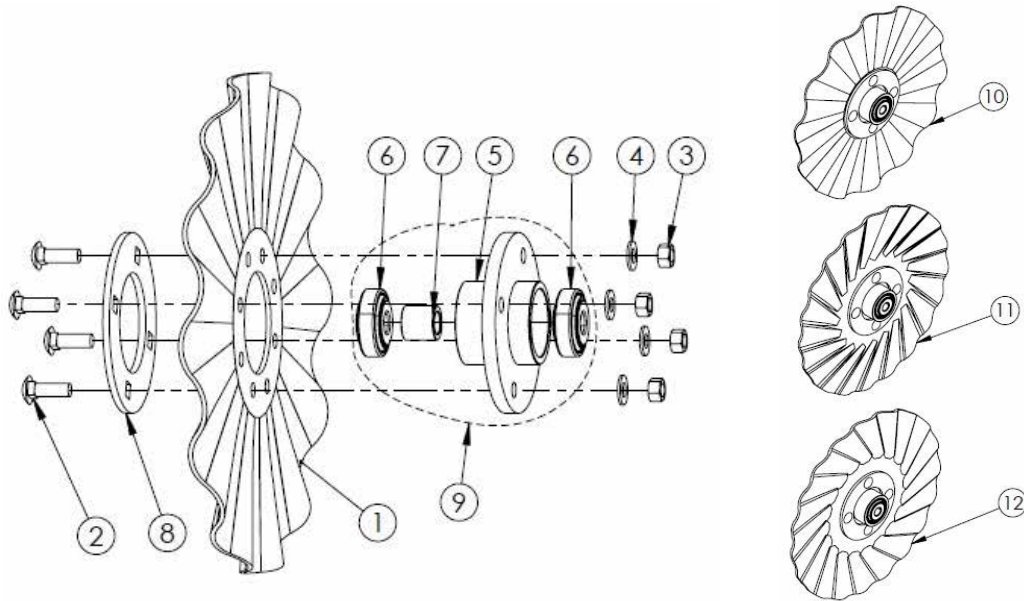

ALL COULTER BLADES USE IDENTICAL PARTS MINUS THE BLADE

Item Number	Part #	Description	Quantity
1	333305	18" WAVY COULTER BLADE	1
1A	305085	18" VT COULTER	1
2	411785	1/2-13 X 1 1/2 CARRIAGE BOLT	4
3	410008	1/2-13 NUT CENTER LOCK Z/C	4
4	413007	1/2 FLAT WASHER SAE Z/C	4
5	305163	COULTER HUB W/O BEARINGS	1
6	305017	3/4 SYMETRIC BEARING	2
7	333310	BEARING SPACER	1
8	305167	COULTER HUB DOUBLER PLATE FINISHED	1
9	305165	COULTER HUB WITH BEARINGS	1
10	333306	18" WAVY COULTER ASSEMBLY	1
11	333384	18" RH VT COULTER ASSEMBLY	1
12	333385	18" LH VT COULTER ASSEMBLY	1



OPTIMIZER BASKET

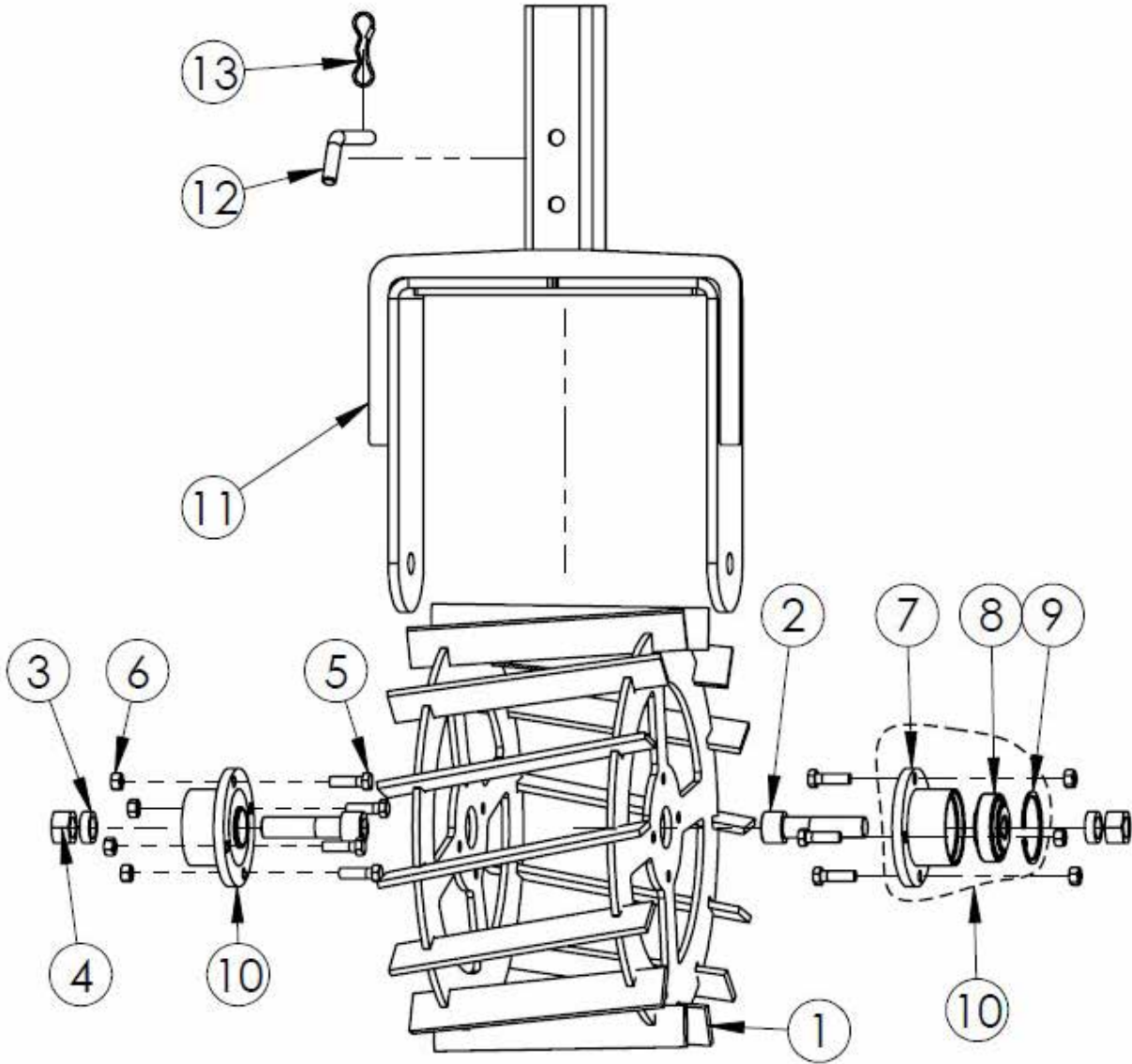



OPTIMIZER BASKET

Item Number	Part #	Description	Quantity
1	321220	OPTIMIZER BASKET	1
2	414520	3/4-16 X 3 SOCKET HEAD CAP SCREW	2
3	321334	BASKET BUSHING	2
4	410012	3/4-10 NUT CENTER LOCK Z/C	2
5	411508	3/8-16 X 1 1/4 GR5 Z/C	8
6	412006	3/8-16 NUT GR2 Z/C	8
7	305179	OPT. BASKET HUB W/O BEARING	2
8	305017	3/4 SYMETRIC BEARING	2
9	305062	RETAINING RING	2
10	305180	OPT. BASKET HUB ASSEMBLY	2
11	321593	OPT. BASKET FRAME	1
12	333099	1/2 X 4 BENT PIN	1
13	333021	COTTER PIN BOWTIE	1



IRON TIRES

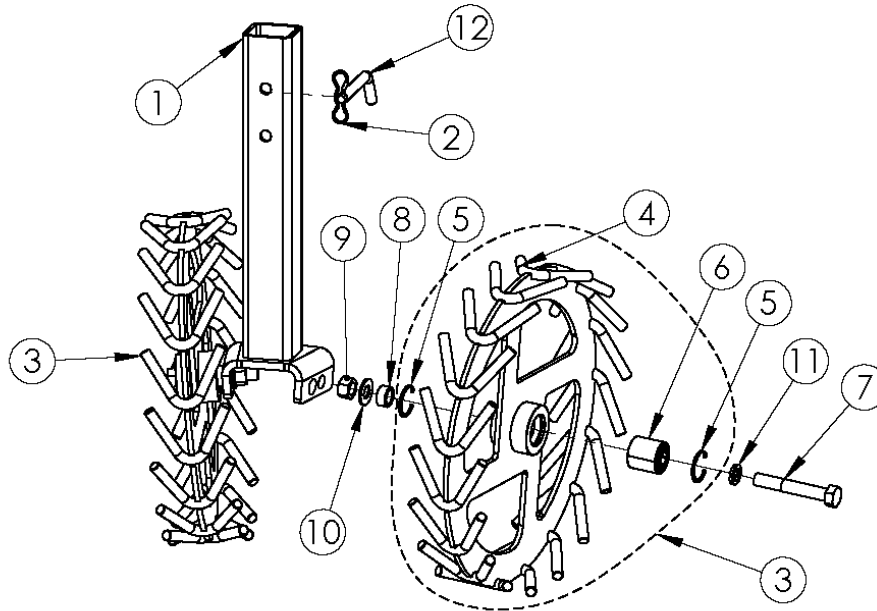

Item Number	Part #	Description	Quantity
1	321332	ASSEMBLY	1
2	333021	COTTER PIN BOW TIE .120 WIRE X 2.75 OAL	1
3	333152	STEEL WHEEL ASSY	1
4	333149	IRON TIRES	1
5	333151	40MM INTERNAL RETAINING RING	2
6	333097	PEER BEARING 5203KYY2	1
7	411222	5/8-11 X 4 GR5 Z/C	2
8	333077	1.000 OD X .156 WALL DOM ASTM A513 TYPE 5 (.688 ID)	2
9	410009	5/8-11 NUT CENTER LOCK GR2 Z/C	2
10	413011	5/8 FLAT WASHER SAE Z/C	2
11	333205	10GA X 5/8 X 1 MACHINE BUSHING	2
12	333099	1/2 X 4 BENT PIN	1



FLEXBERM MOUNT

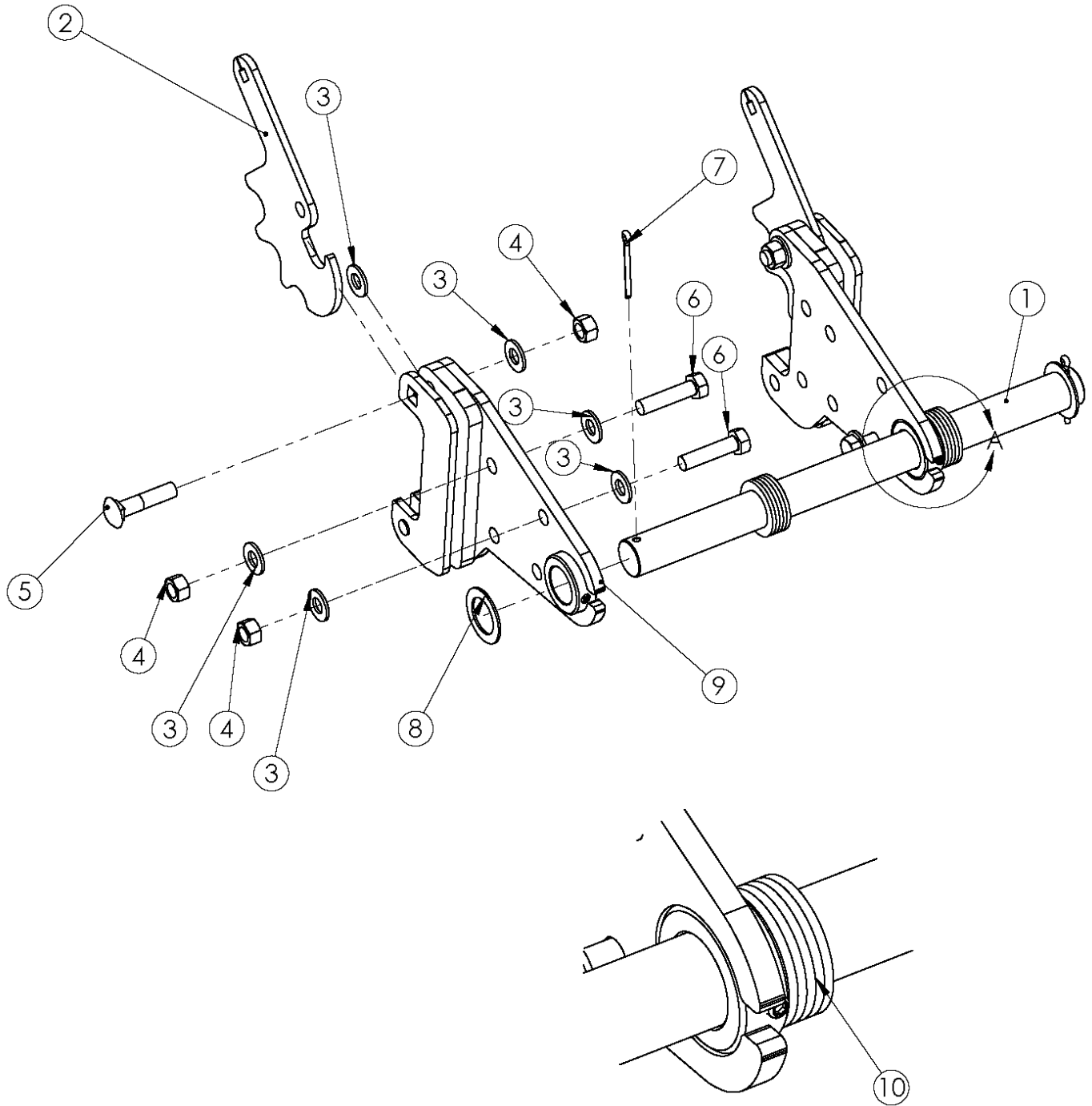

DETAIL A
SCALE 1 : 2



FLEXBERM MOUNT

Item Number	Part #	Description	Quantity
1	333484	VERTISTRIP FLEXBERM PIVOT PIN	1
2	321661	FLEXBERM HEIGHT ADJUST HANDLE	1
3	413007	1/2 FLAT WASHER SAE Z/C	6
4	410008	1/2-13 HEX NUT CENTER LOCK GRA Z/C	3
5	411734	1/2-13 X 2 1/4 CARRIAGE BOLT GR5 Z/C	1
6	411184	1/2-13 X 2 HEX BOLT GR5 Z/C	2
7	416014	COTTER PIN 3/16 X 2 PLATED Z/C	2
8	321684	1 1/4 X 1 7/8 X 14GA MACHINE BUSHING Z/C	2
9A	333488	LH FLEXBERM MOUNT (NOT SHOWN)	1
9B	333489	RH FLEXBERM MOUNT	1
10	321672	1 1/4 X 1 7/8 X 10GA MACHINE BUSHING Z/C	5



FLEXBERM ARM

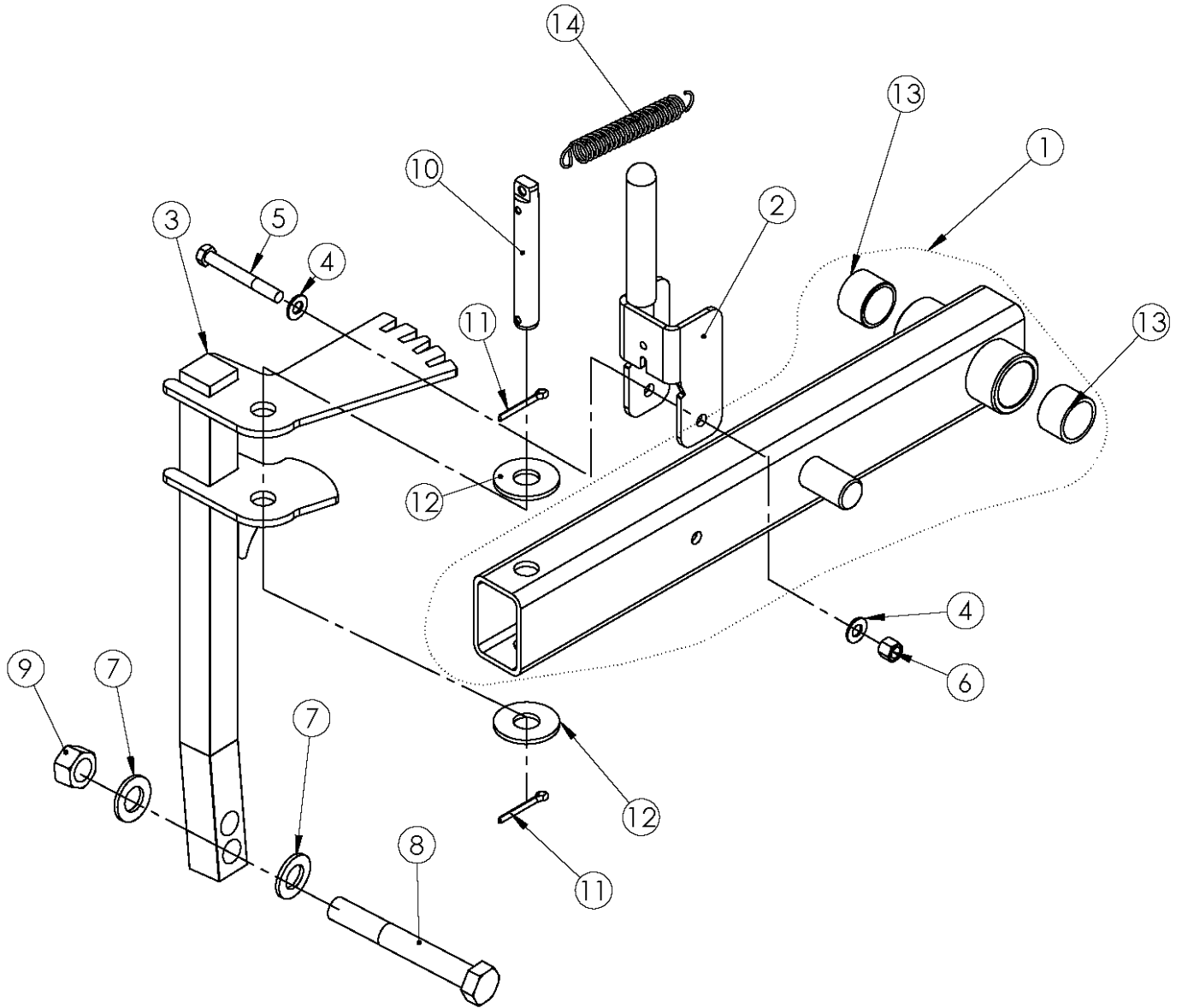



FLEXBERM ARM

Item Number	Part #	Description	Quantity
1	333480	VS FLEXBERM ARM	1
2	321657	FLEXBERM HANDLE ASSY	1
3A	321647	FLEXBERM LH DOWN ARM	1
3B	321648	FLEXBERM RH DOWN ARM(NOT SHOWN)	1
4	413009	3/8 FLAT WASHER SAE Z/C	2
5	411150	3/8-16 X 3 GR2 Z/C	1
6	305106	3/8-16 NUT NYLON LOCK Z/C	1
7	413072	3/4 FLAT WASHER SAE Z/C	2
8	411595	3/4-10 X 5 1/2 GR5 Z/C	1
9	410012	3/4-10 NUT CENTER LOCK Z/C	1
10	321644	ANGLE ADJUST PIN	1
11	416012	3/16 X 1 1/2 COTTER PIN PLATED Z/C	2
12	413012	3/4 FLAT WASHER USS Z/C	2
13	305027	COULTER ARM POLY BUSHING	2
14	321651	TENSION SPRING	1



HYDRAULIC TRIP CYLINDER

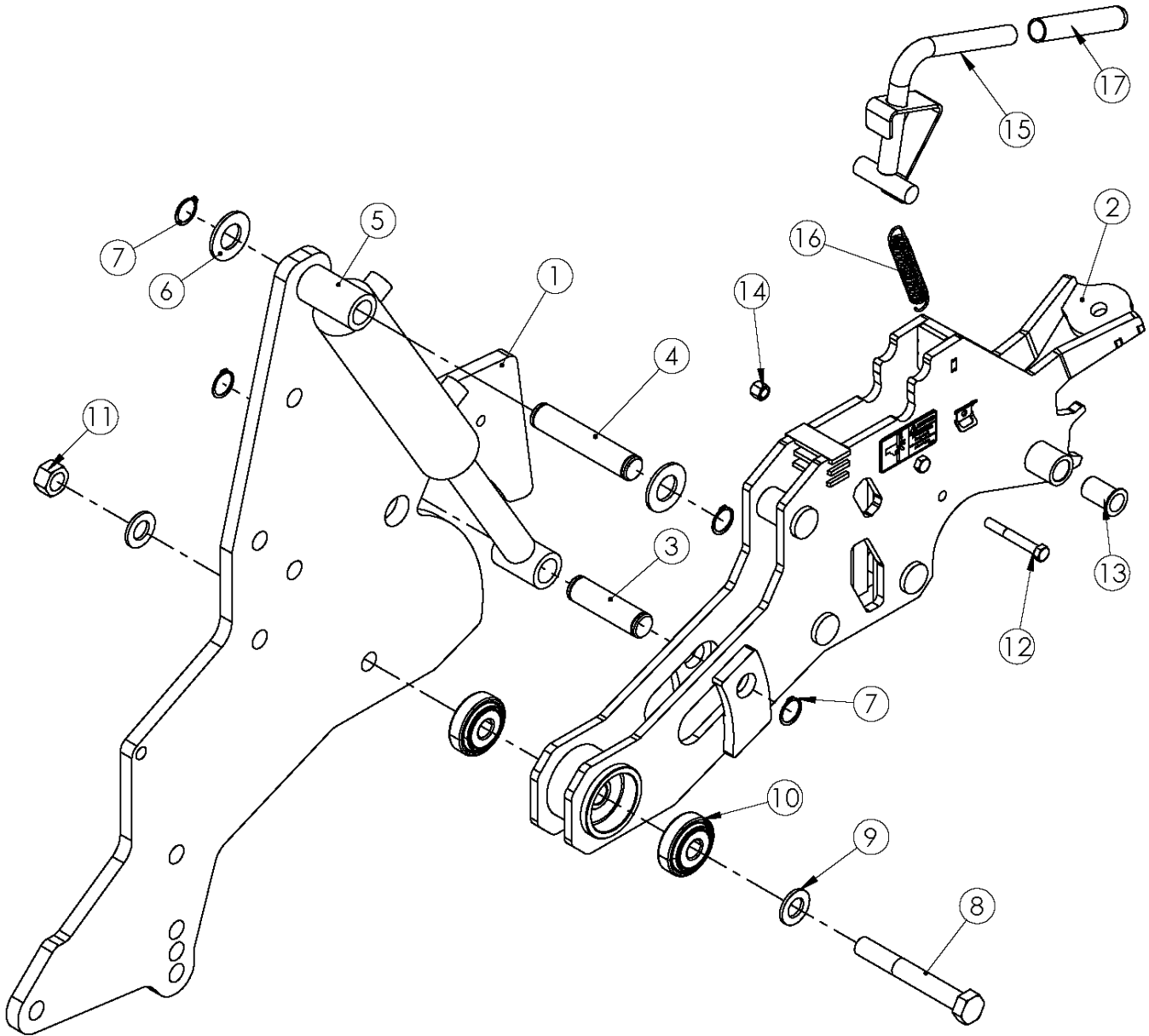



HYDRAULIC TRIP CYLINDER

Item Number	Part #	Description	Quantity
1	333549	VERTISTRIP HYD TRIP SIDE PLATE FINISHED	1
2	333547	HYD TRIP SHANK HOUSING ASSY	1
3	333538	BOTTOM TRIP PIN	1
4	333537	TOP TRIP PIN	1
5	476001	HYDRAULIC CYLINDER 2 X 6 WELDED	1
6	413019	1 FLAT WASER SAE Z/C	2
7	315137	1" EXTERNAL RETAINING RING	4
8	411595	3/4-10 X 5 1/2 HEX BOLT GR5 Z/C	1
9	413072	3/4 FLAT WASHER SAE Z/C	2
10	305017	BEARING FOR 3/4 SHAFT SYMMETERICAL	2
11	410012	3/4-10 HEX NUT CENTER LOCK GRA Z/C	1
12	411149	3/8-16 X 2 3/4 HEX BOLT GR5 Z/C	2
13	321499	SLEEVE FLANGE BEARING PLASTIC 1 1/2 X 3/4 SHAFT	2
14	305106	3/8-16 HEX NUT NYLON LOCK GR5 Z/C	2
15	316017	CULTIVATOR HANDLE WELDMENT	1
16	321651	TENSION SPRING HOCK ENDS 3 X 3/4 OD X .075 WIRE Z/C	1
17	321673	ROUND GRIP RUBBERIZED COARSE .75 X 4.5 BLACK	1



HYDRAULIC TRIP ROW UNIT

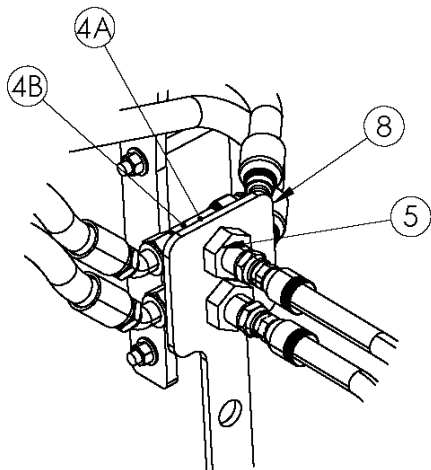
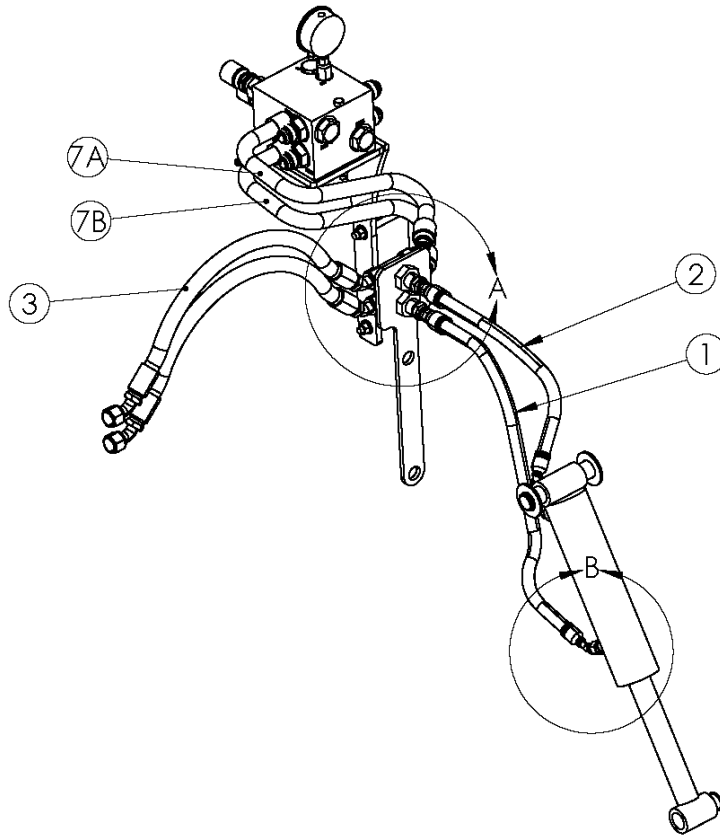

DETAIL A
SCALE 1 : 5

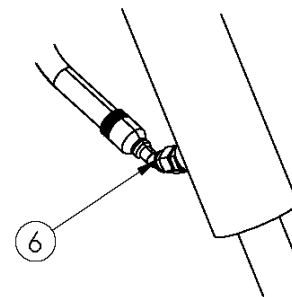

DETAIL B
SCALE 1 : 5



HYDRAULIC TRIP ROW UNIT

Item Number	Part #	Description
1	333532	HOSE ASSEMBLY 30" LONG -6FJIC 45° X -10FJIC STRAIGHT -6 HOSE
2	333533	HOSE ASSEMBLY 24" LONG -6FJIC 45° X -10FJIC STRAIGHT -6 HOSE
3	333232	HOSE ASSEMBLY 20/22" SPACING -10 FJIC 45 -10 FJIC 45
4A	333226	FITTING BULKHEAD 10MJIC TEE
4B	333226	FITTING BULKHEAD 10MJIC TEE
5	333227	FITTING BULKHEAD 7/8-14 NUT
6	457246	FITTING 90 6 MORB TO 6 MJIC
7A	333247	HOSE ASSEMBLY 20/22/30" SPACING MANIFOLD TO BULKHEAD
7B	333247	HOSE ASSEMBLY 20/22/30" SPACING MANIFOLD TO BULKHEAD



HYDRAULIC TRIP - MANIFOLD TO TRACTOR

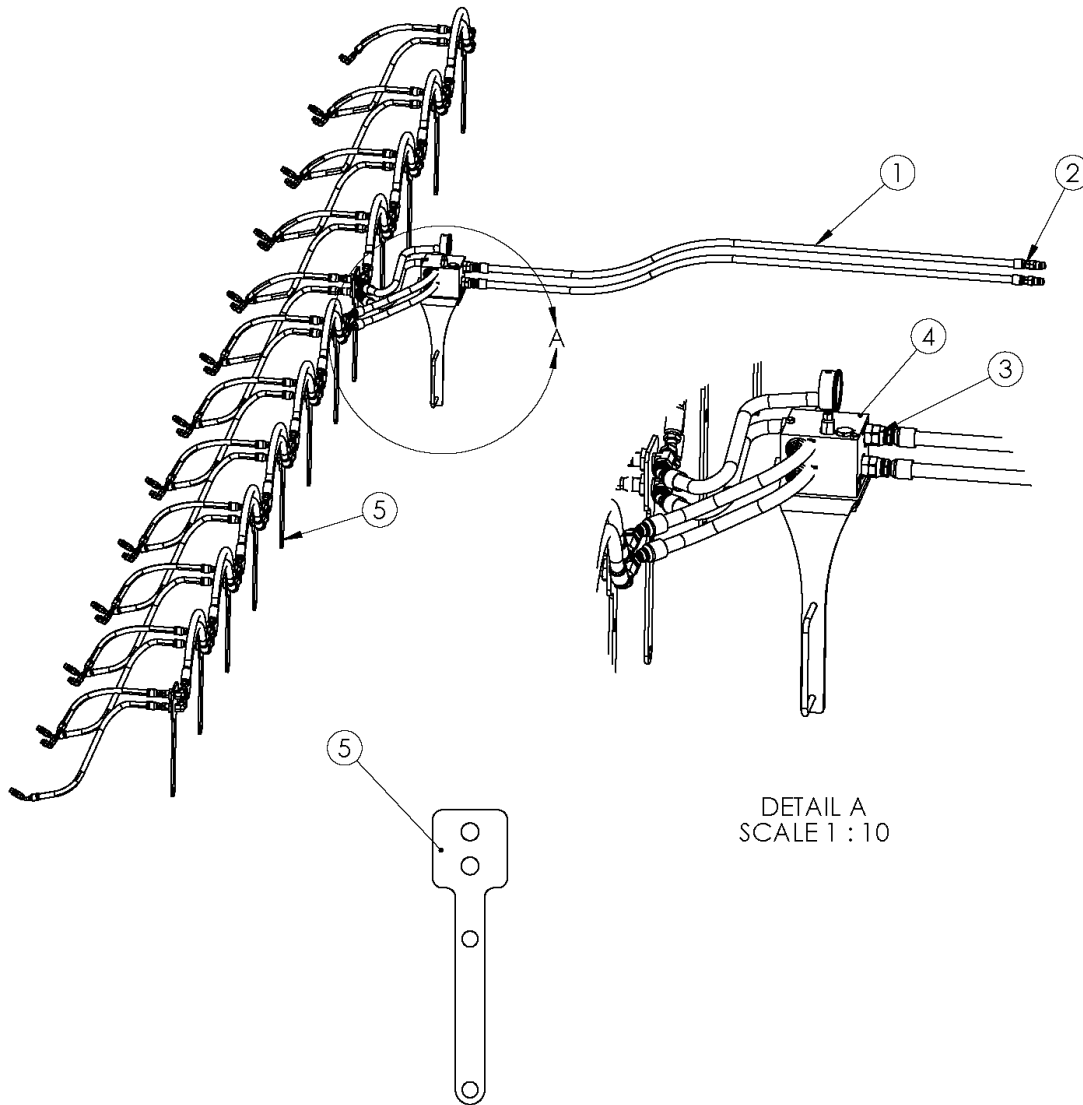

Item Number	Part #	Description
1	333246	HOSE ASSEMBLY 72" LONG 12 FJIC - 8 MORB
2	333245	8 ORB ISO TRACTOR 1/2" QUICK COUPLER
3	333248	FITTING 12 FJIC TO 12 MORB COUPLER STRAIGHT
4	333242	VERTISTRIP MANIFOLD BRACKET ASSEMBLY
5	333535	VERTISTRIP HYD TRIP HOSE BRACKET



KNIFE ADAPTER

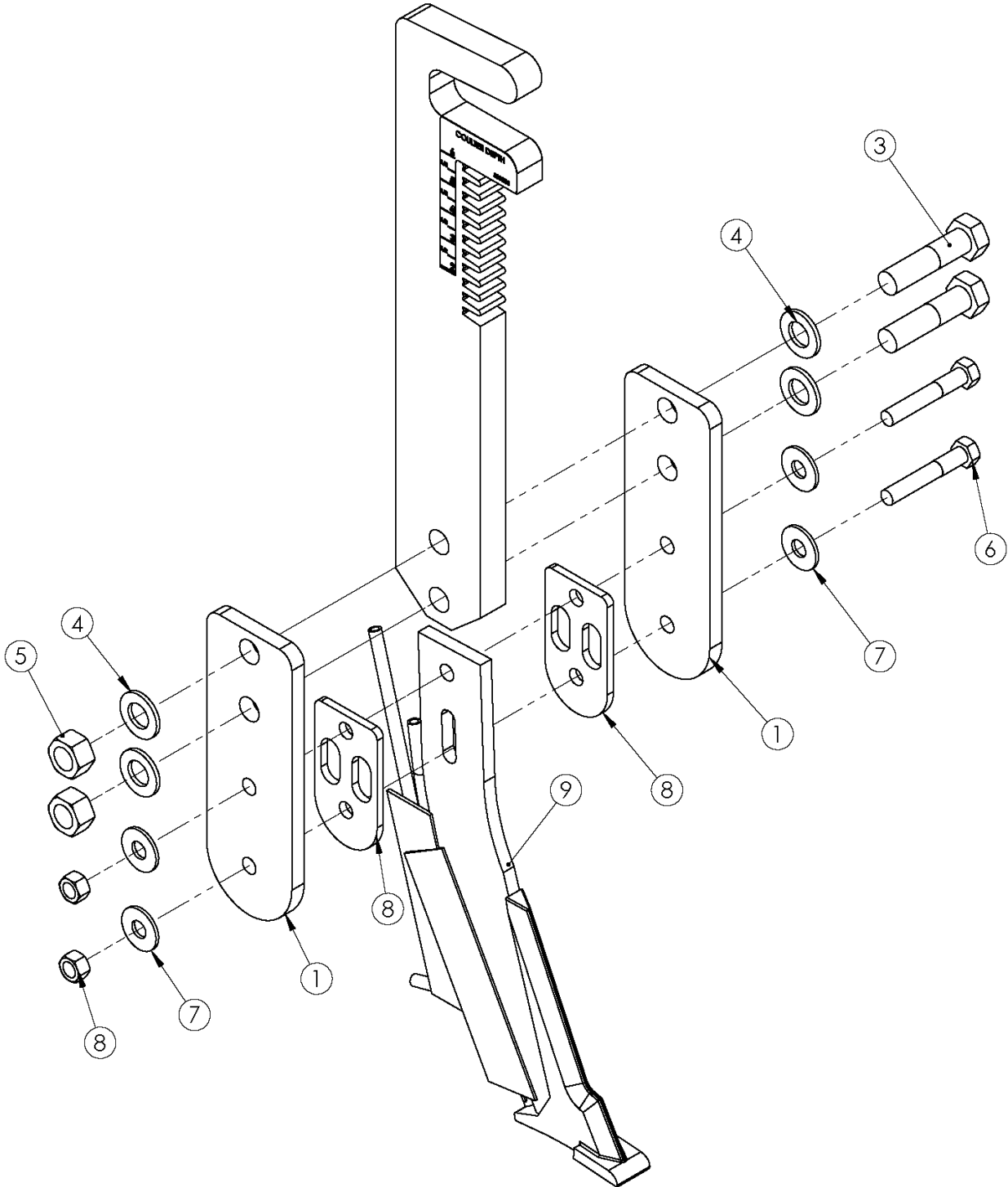



KNIFE ADAPTER

Item Number	Part #	Description	Quantity
1	333524	KNIFE PLATE ADAPTER	2
2	411589	3/4-10 X 3 GR5 Z/C	2
3	413072	3/4 FLAT WASHER SAE Z/C	4
4	412012	3/4-10 NUT GR2 Z/C	2
5	411551	1/2-13 X 3 GR5 Z/C	2
6	413008	1/2 FLAT WASHER USS Z/C	4
7	412058	1/2-13 NUT GR5 Z/C	2
8	333496	VERTISTRIP KNIFE ADAPTOR SPACER PLATE	2
9	333890	DUAL 3/8" TUBES MINI MOLE	1
NOT SHOWN	333891	DRY ONLY MINI MOLE	1
NOT SHOWN	333892	DUAL 3/8" TUBES - 1.5" DRY MINI MOLE	1
NOT SHOWN	333895	DUAL 3/8" TUBES MOLE	1
NOT SHOWN	333896	DRY ONLY MOLE	1
NOT SHOWN	333897	DUAL 3/8" TUBES - 1.5" DRY MOLE	1

PARTS GUIDE



LIQUID ADAPTER

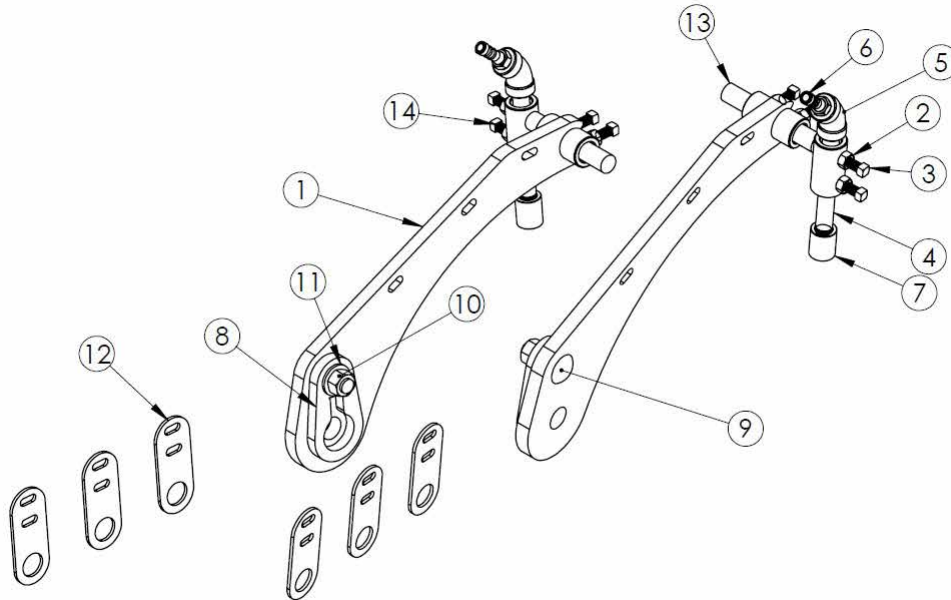

Item Number	Part #	Description	Quantity
1	333415	SPRAY ARM WELDMENT	2
2	PP000274	5/16-18 NUT SS	6
3	PP000190	5/16-18 X 1 SQ HEAD SET SCREW SS	6
4	10000056	NIPPLE 1/4 NPT X 5 INCH 304SS	2
5	10000054	ELBOW 45 DEGREE 1/4 NPT FEMALE 304SS	2
6	HNF20003	ADAPTER 1/4 NPT MALE X 3/8 ID HOSE BARB HEX 304SS	2
7	10000055	COUPLER 1/4 NPT 304SS	2
8	333419	KEY PLATE	2
9	411785	1/2-13 X 1 1/2 CARRIAGE BOLT	2
10	410008	1/2-13 NUT CENTER LOCK Z/C	2
11	413007	1/2 FLAT WASHER SAE Z/C	2
12	333422	HOSE GUIDE FINISHED	6
13	333432	SPRAY ADAPTER W/O HARDWARE	1
14	333434	SPRAY ADAPTER WITH HARDWARE	1



NOTE: This page is intentionally left blank.

PARTS GUIDE



AIR CONTROLLER AND AIR SYSTEM

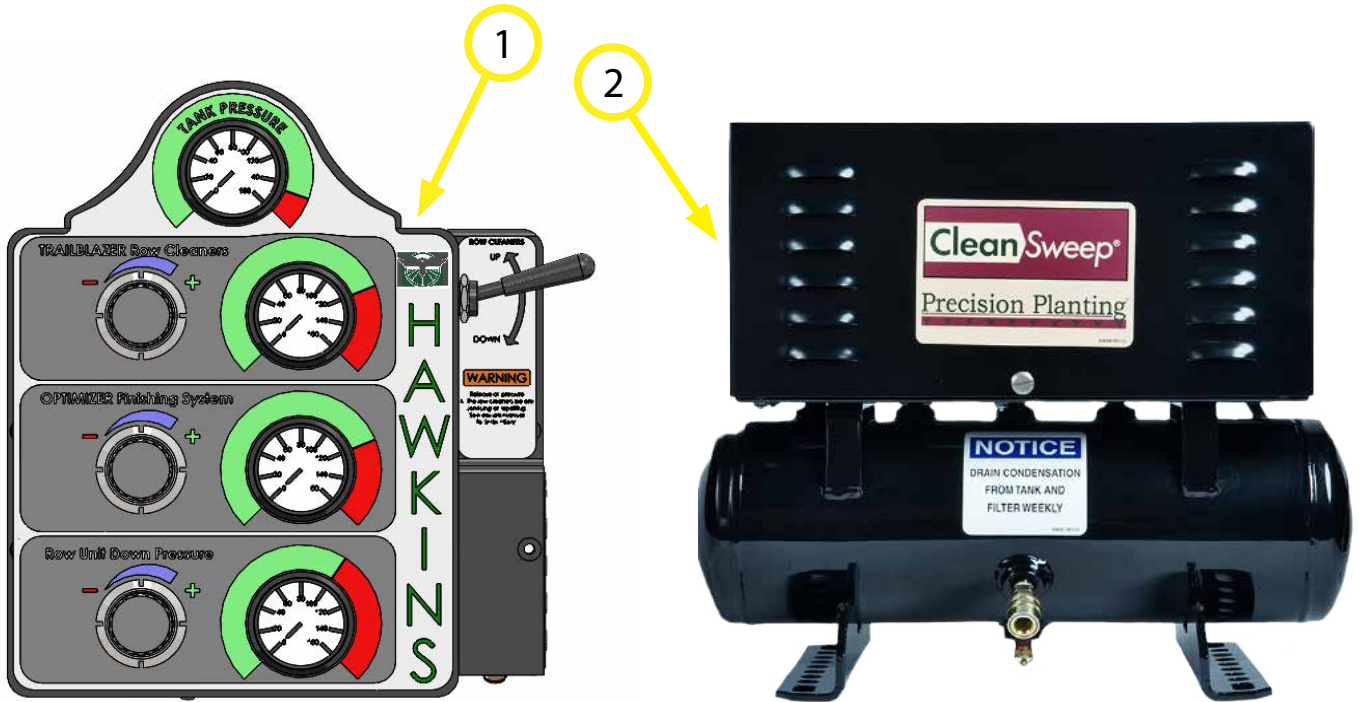

Item Number	Part #	Description	Quantity
1	321584	VERTISTRIP AIR CONTROLLER, PLEASE CONTACT HAWKINS AG SERVICE DEPARTMENT FOR PARTS OR SUPPORT	1
2	321585	AIR COMPRESSOR, PLEASE SEE AIR COMPRESSOR MANUAL FOR PARTS	1



HAWKINS

308.708.8185 | HAWKINSAG.COM
PO BOX 2618, KEARNEY, NE 68848